

LECTURE NOTES ON

# LAND SURVEYING-I

DEPARTMENT OF CIVIL ENGG.



PREPARED BY-ER.BISWAJIT BEHERA

# COURSE CONTENT

- 1. INTRODUCTION TO SURVEYING. LINEAR MEASUREMENTS**
- 2. CHAINING AND CHAIN SURVEYING**
- 3. ANGULAR MEASUREMENTS AND COMPAS SURVEYING**
- 4. MAP READINGS AND CADASTRAL MAPS & NOMENCLATURE**
- 5. PLANE TABLE SURVEYING**
- 6. THEODOLITE SURVEYING AND TRAVERSING**
- 7. LEVELLING AND CONTOURING**
- 8. COMPUTATION OF AREA AND VOLUME**

## CHAPTER-1

### INTRODUCTION TO SURVEYING, LINEAR MEASUREMENTS

#### INTRODUCTION:-

#### SURVEYING-

Surveying is the art of determining the relative position of different objects on the surface of the earth by means of measurements of distances, directions and elevations and then, preparing a map to any suitable scale.

#### TECHNICAL TERMS:

*Plan:* A plan is a geographical representation of the features on the earth surface or below the earth surface as projected on horizontal plane. This may not necessarily show its geographical position on the globe. On a plan horizontal distances and directions are shown.

*Map:* The representation of earth surface on a small scale is called a map. The map must show its geographical position on the globe.

*Topographical map:* The maps which are on sufficiently large scale to enable the individual features shown on the map to be identified on the ground by their shapes and positions are called topographical map.

*Geographical map:* The maps which are on such a small scale that the features shown on the map are suitably generalized and the map gives a picture of the country as a whole and not a strict representation of its individual features, are called geographical maps.

#### 1.1. AIM AND OBJECTIVES OF SURVEYING-

The aim of surveying is to prepare a map to show the relative positions, horizontal distances, and elevation of the objects on the surface of the earth. The map is drawn to some suitable scale. It shows the natural features of a country, such as towns, villages, roads, railways, river etc. The objectives of surveying can be stated as follows.

- (i) Collect and record data on the relative positions of points on the surface of the earth.
- (ii) Compute areas and volumes using this data, required for various purposes.
- (iii) Prepare the plans and maps required for various activities.
- (iv) Lay out, using survey data, the various engineering works in correct positions.
- (v) Check the accuracy of laid out lines, built of structure.

#### 1.3 CLASIFICATION OF SURVAYING-

##### (1) PRIMARY CLASSIFICATION

Surveying is primarily classified as:

1. Plane surveying
2. Geodetic surveying

### **PLANE SURVEYING:**

In plane surveying the curvature of the earth is not taken into consideration. This is because surveying is carried out over a small area so the surface of the earth is considered as plane. Plane surveying is done on an area of less than 250km<sup>2</sup>.

### **GEODETTIC SURVEYING:**

In geodetic surveying the curvature of the earth is taken into consideration. It is extended over a large area. It is carried out over an area exceeding 250 km<sup>2</sup>.

## **(2) SECONDARY CLASSIFICATION**

Chain surveying

Compass surveying

Plane table surveying

Theodolite surveying

Tachometric surveying

### **1.4 GENERAL PRINCIPLE OF SURVEYING-**

The two basic principles of surveying need to be followed for accurately locating points on earth.

#### *1. To work from the whole to part:*

The main principle of surveying is to work from whole to part whether it is plane or geodetic surveying. To achieve this in actual practice, a sufficient number of primary control points are established with higher precision in and around the area to be detailed surveyed. Minor control points in between the primary control points are then established with less precise methods. Further details are surveyed with the help of these minor control points by adopting any of the survey methods. The main idea of working from whole to part is to prevent accumulation of errors and localize minor errors within the framework of control points. On the other hand if survey is carried out from part to whole, the errors would expand to greater magnitudes and the scale of the survey will be distorted beyond control.

In general practice the area is divided into a number of large triangles and the positions of their vertices are surveyed with greater accuracy, using sophisticated instruments. These triangles are further divided into smaller triangles and their vertices surveyed with less accuracy.

#### *2. To locate a new station by at least two measurements from fixed reference points / control points.*

The reference points / control points are selected in the area and distance between them, is measured accurately. The line is then plotted to a convenient scale on a drawing sheet. In case, the control points are co-ordinated, their locations may be plotted with the system of coordinates (Cartesian or spherical). The

location of the required point may then be plotted by making two measurements from the given control points as explained below.

Let P and Q be two given control points. Any other point R can be located with reference to these points, by any of the following methods.

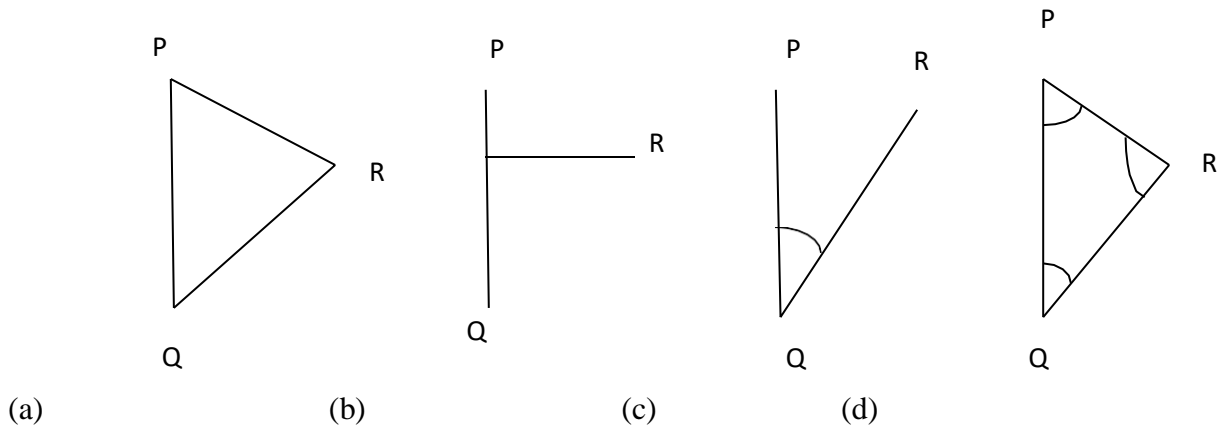

Fig.1

(i) *By measuring distances PR and QR:-* The distances PR and QR may be measured and the location of R may be plotted by drawing arcs to the same scale to which line PQ has been drawn as shown in Fig 1 (a).

(ii) *By dropping a perpendicular from R on PQ:-* A perpendicular RT may be dropped on the line PQ. Distances PT, TQ and RT are measured and the location of R may be plotted by drawing the perpendicular RT to the same scale to which line PQ has been drawn (Fig. 1 (b)).

The above two principles are generally used in “Chain surveying”.

(iii) *By measuring the distance QR and angle PQR:-* The distance QR and the angle PQR equal to  $\alpha$  are measured and location of R may be plotted either by means of a protractor or trigonometrically (Fig 1 (c)),

This principle is used in “Theodolite traversing”.

(iv) *By measuring the interior angles of the triangle PQR:-* The interior angles P, Q and R of the triangle PQR are measured with an angle measuring instrument such as theodolites. The length of sides PR and QR are calculated by solving the triangle PQR and coordinates of R are calculated in the same terms as those of P and Q. Even without calculating the co-ordinates, or sides the location of R can be obtained by plotting the angles PQR and QPR (Fig 1(d)).

This principle is used in the method of 'Triangulation'.

## **LINEAR MEASUREMENTS**

### **2.1 INTRODUCTION**

There are two main methods of determining the distances between points on the surface of earth:

- (i) *Direct Measurement:* In this method, distances are actually measured on the earth surface by means of **chains, tapes** etc.
- (ii) *Computative Measurement:* In this method distances are determined by calculation as in tachometry and triangulation.

### **2.2 INSTRUMENTS FOR MEASURING DISTANCES**

- (i) Tapes
- (ii) Steel Bands
- (iii) Chains
- (iv) Arrows
- (v) Pegs
- (vi) Ranging Rods
- (vii) Ranging Poles
- (viii) Offset Rods
- (ix) Plumb Bobs

### **2.3 TAPES:** Depending upon the material tapes are classified as

- (i) Cloth or linen tape
  - (ii) Metallic tape
  - (iii) Steel tape
  - (iv) Invar tape
- (i) *Cloth or linen tape:* Linen tapes are closely woven linen and varnished to resist moisture. They are generally 10 meters' to 30 meters in length and 12mm to 15 mm in width. Cloth tapes are generally used for measuring offset measurements only due to following reasons :
- (i) It is easily affected by moisture and shrunk.
  - (ii) Its length gets altered by stretching.

- (iii) It is likely to twist and tangle.
  - (iv) It is not strong as a chain or steel tape.
  - (v) It is light and flexible and it does not remain straight in strong wind.
  - (vi) Due to continuous use, its figures get in-distinct.
- (ii) ***Metallic Tape:*** A linen tape reinforced with brass or copper wires to prevent stretching or twisting of fibers is called a metallic tape. As the wires are interwoven and the tape is varnished, these wires are not visible to naked eyes. These tapes are available in different lengths but tapes of 20m and 30m lengths are very common. These are supplied in leather case with winding machine. Each metre is divided into decimeters and each decimeter is sub-divided into centimeters.
- (iii) ***Steel Tape:*** Steel tapes are available with different accuracy of graduation. Steel tapes are available in different lengths but 10m, 20m, 30m and 50m tapes are widely used in survey measurements. At the end of the tape a brass ring is provided. The length of metal ring is included in the length of tape. A steel tape of lowest degree of accuracy is generally superior to a metallic or cloth tape for linear measurements.
- (iv) ***Invar Tape:*** Invar tapes are made of an alloy of nickel (36%) and steel (64%) having very low coefficient of thermal expansion (0.000000122 per 1°C). These are 6mm wide and are available in length of 30m, 50m and 100m. These tapes are used for high degree of precision required for base measurements.

2.4 **Chains:** The different types of chains are used in surveying and are given below.

- (1) *Gunter's chain:* It is 66ft. long and divided into 100 links. Each link measures 0.66 ft.
- (2) *Engineer's chain:* It is 100ft. long and divided into 100 links. Each link measures 1 ft.

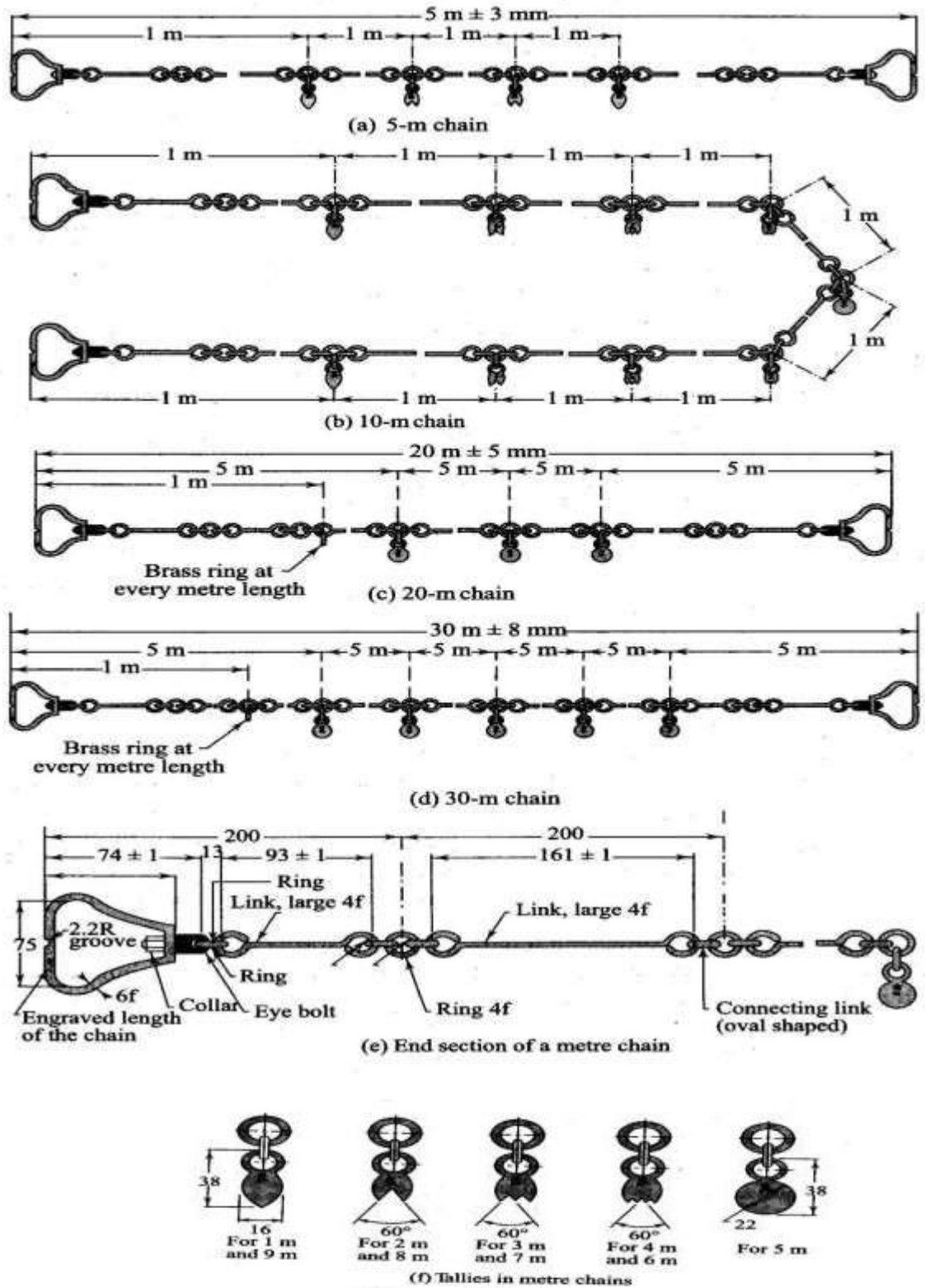

Fig. 2.1



(3) *Metric Chain:* A metric chain is prepared with 100 or 150 pieces/ links of galvanized mild steel wire of diameter 4mm. The ends of the pieces are bent to form loops and connected together by means of three oval shaped rings which gives flexibility to the chain. Two brass handles are provided at the two ends of the chain with swivel joints so that chain can be turned round without twisting. The outside of the handle is the zero point or the end point of the chain. The length of the chain is measured from the outside of one handle to the outside of the other. The length of a link is the distance between the centres of the two consecutive middle rings as shown in the Fig. 2.1. The end links include the length of handle. Tallies are provided for marking 5m, 10m, etc are marked with letter “m” to distinguish the metric chain from non-metric chain. The length of chain whether 20m Or 30m is indicated on the handle for easy identification.

***Suitability of Chains:***The chains are suitable for the following cases.

- (i) It is suitable for ordinary or preliminary works as its length alters due to continuous use.
- (ii) Its length gets shortened due to bending of links and gets lengthened by flattening of the rings.
- (iii) Being heavier, a chain gets sagged considerably when suspended at the ends.
- (iv) It can be easily repaired in the field.
- (v) Measurement readings can be taken very easily.
- (vi) It is only suitable for rough works.

***Merits of Chains:***

- (i) They can be read easily and quickly
- (ii) They can withstand wear and tear
- (iii) They can be easily repaired or rectified in the field.

***Demerits of Chains:***

- (i) They are heavy and take too much time to open or fold.
- (ii) They become longer or shorter due to continuous use.
- (iii) When the measurement is taken in suspension the chain sags excessively giving incorrect measurements.

***ARROWS:*** Arrow are made of tempered steel wire of diameter 4mm. One end of the arrow is bent into a ring of diameter 50 mm and the other end is pointed. Its overall length is 400mm. Arrows are used for counting the number of chains while measuring a chain line. Generally 10 arrows accompany a chain.

***RANGING RODS:***Rods, which are used for ranging a line are known as ranging rod. Such rods are made of seasoned timber or seasoned bamboo. Sometimes GI pipes of 25mm/ 30mm diameter are also used as ranging

rods. They are generally circular in section of diameter 25mm/30mm and length 2m / 3m. The rod is divided into equal parts of 20cm each and the divisions are painted black and white or red and white alternatively so that the rod is visible from a long distance. The lower end of the rod is pointed or provided with an iron shoe.

**RANGING POLES:** These are similar to ranging rods except that they are heavier in section of length 4m to 6m. They are used for ranging very long lines in undulating ground.

**OFFSET RODS:** These are similar to ranging rods and 3m long. The top is provided with an open hook for pulling or pushing a chain through obstruction like bushes etc. It is used for aligning the offset line and measuring short offsets.

**PLUMB BOB:** It is used to transfer the end points of the chain onto ground while measuring distances in hilly terrain. It is also used for testing verticality of ranging poles, ranging rods.

**PEGS:** Wooden pegs usually 2.5cm square and 15cm deep are used to mark the position of survey stations.

### **ADJUSTMENT OF CHAIN:**

Chains are adjusted in the following ways-

- (1) When the chain is too long, it is adjusted by
  - (a) Closing up the joints of the rings
  - (b) Hammering the elongated rings
  - (c) Replacing some old rings by new rings
- (2) When the chain is too short, it is adjusted by
  - (a) Straightening the bent links
  - (b) Opening the joints of the rings
  - (c) Replacing the old rings by some larger rings

### **2.5 ERRORS IN LINEAR MEASUREMENTS /CHAINING**

Errors in chaining may be caused due to variation in temperature and pull, defects in instruments etc. They may be classified into two categories.

- (i) Compensating errors
  - (ii) Cumulative error
- (i) **COMPENSATING ERRORS:** Errors, which may occur in both directions (that is both positive and negative) and which finally tend to compensate are known as compensating errors.

(ii) **CUMULATIVE ERRORS:** Errors, which may occur in the same direction and which finally tend to accumulate are said to be cumulative. They seriously affect the accuracy of the work and are proportional to the length of the line(L). The errors may be positive or negative.

I. **Positive Cumulative Error:** The error, which make the measured length more than the actual is known as positive cumulative error.

*Sources:*(a) The length of chain / tape is shorter than its standard length due to

- Bending of links
- Removal of too many rings due to adjustment of its length.
- Knots in connecting links.
- The field temperature is lower than that at which the tape was calibrated.
- Shrinkage of tape when moist
- Clogging of rings with mud.

(b) The slope correction is ignored while measuring along slopping ground.

(c) The sag correction, if not applied when chain / tape is suspended at its ends.

(d) Incorrect alignment.

II. **Negative Cumulative Error:** The error, which make the measured length less than the actual is known as negative cumulative error.

*Sources:* (a) The length of chain / tape is longer than its standard length due to

- Flattening of connecting rings.
- Opening of the ring joints.
- The field temperature is higher than that at which the tape was calibrated.

### **MISTAKES:**

Errors occurring due to the carelessness of the chainman are called mistakes. Following are a few common mistakes:

(1) Once an arrow is withdrawn from the ground during chaining it may not be replaced in proper position, if required due to some reason.

(2) A full chain length may be omitted or added. This happen when arrows are lost or wrongly counted.

(3) The number may be read from the wrong direction; for instance a 6 may be read as a 9.

(4) Some number may be called wrongly. For example 50.2 may be called as fifty two without the decimal point being mentioned.

## PRECAUTIONS AGAINST ERRORS AND MISTAKES:

- (1) The point where the arrow is fixed on the ground should be marked with a cross(×).
- (2) The zero end of the chain or tape should be properly held.
- (3) During chaining the number of arrows carried by the follower and leader should always tally with the total number of arrows taken.
- (4) The chainman should call the measurement loudly and distinctly and the surveyor should repeat them while booking.
- (5) Ranging should be done accurately.
- (6) No measurement should be taken with the chain in suspension.

### ***ERRORS IN MEASUREMENT DUE TO INCORRECT CHAIN / TAPE LENGTH:***

Due to usage of chain over rough ground, its oval shaped rings get elongated and thus the length of chain gets increased. On the other hand, sometimes some of the links get bent and consequently the length of the chain gets decreased. Thus, the lengths obtained by chaining with a faulty chain are either too long or too short than the length which would be obtained with a chain of standard length. *If the chain is too long the measured distance will be less and if the chain is too short the measured distance will be more.*

Let  $L$  be the true length of chain and  $L'$  be the faulty length of chain.

Then, *the true length of a line* =  $\frac{L'}{L} \times \text{measured length}$

## 2.6 CORRECTIONS IN LINEAR MEASUREMENTS

- (i) Correction for standard length
- (ii) Correction for alignment
- (iii) Correction for slope
- (iv) Correction for tension
- (v) Correction for temperature
- (vi) Correction for sag

- (i) ***Correction for standard length:*** Before using a tape, its actual length is ascertained by comparing it with a standard tape of known length. The designated nominal length of a tape is its designated length e.g. 30m or 100m. The absolute length of a tape is its actual length under specified conditions.

Let  $L$  = measured length of a line

$C_a$  = correction for absolute length

$l$  = nominal designated length of tape

$C$  = correction be applied the tape

Then, 
$$C_a = \frac{L.C}{l}$$

The sign of the correction  $C_a$  will be the same as that of  $C$ .

- (ii) **Correction for alignment:** Generally a survey line is set out in a continuous straight line. Sometimes, it becomes necessary, due to obstruction to follow a bent line which may be composed of two or more straight portions subtending an angle other than  $180^\circ$  as shown in Fig.2.2.

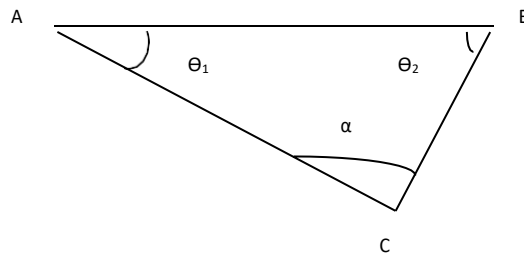

Fig.2.3. Correction for alignment

Let  $AC=l_1$ ;  $CB=l_2$

Angle  $BAC = \theta_1$ ; Angle  $ABC = \theta_2$

Length  $AB = l_1 \cos \theta_1 + l_2 \cos \theta_2$

The required correction  $= (l_1 + l_2) - (l_1 \cos \theta_1 + l_2 \cos \theta_2)$

- (iii) **Correction for slope:** The distance measured along the slope between two stations is always greater than the horizontal distance between them. The difference in slope distance and horizontal distance is known as slope correction which is always subtractive.

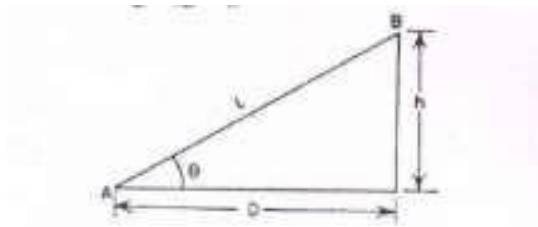

Fig. 2.4 Slope Correction

Let  $L$  = slope distance AB  
 $D$  = horizontal distance AC  
 $h$  = difference in reduced levels of A and B

$$D = \sqrt{(L^2 - h^2)}$$

$$\text{Slope Correction} = L - D = \frac{h^2}{2L}$$

**(iv) Correction for pull/ tension ( $C_P$ ):**

During measurement the applied pull may be either more or less than the pull at which the chain or tape was standardized. Due to the elastic property of materials the strain will vary according to the variation of applied pull and hence necessary correction should be applied. This correction is given by the expression

$$C_P = \frac{(P - P_0) \times L}{A \times E}$$

where,  $P$  = Pull or tension applied during measurement in Newtons

$A$  = Cross-sectional area of the tape in square cm.

$L$  = Length of the measured line

$P_0$  = Standard pull

$E$  = Modulus of Elasticity of the tape

*If the applied pull is more, tension correction is positive, and if it is less, the correction is negative.*

**(v) Temperature correction ( $C_t$ ):**

This correction is necessary because the length of the tape or chain may be increased or decreased due to rise or fall of temperature during measurement. The correction is given by the expression as mentioned below.

$$C_t = \alpha(T_m - T_0)L$$

where  $C_t$  = correction for temperature

$\alpha$  = coefficient of thermal expansion

$T_m$  = temperature during measurement in degrees centigrade

$T_0$  = temperature at which the tape was standardized in degrees centigrade

$L$  = length of tape

**(vi) Correction for sag ( $C_s$ )**

This correction is necessary when the measurement is taken with the tape in suspension. It is given by the expression as mentioned below.

$$C_s = \frac{L}{24} \left( \frac{W}{P} \right)^2$$

where W= total wt of the tape; L= horizontal distance between the supports

P = pull applied during measurement

**Problem 1.** *The length of a survey line measured with a 30m chain was found to be 631.5m. When the chain was compared with a standard chain, it was found to be 0.1m too long. Find the true length of the survey line.*

**Solution**

The true length of a line =  $\frac{L'}{L} \times \text{measured length}$

$L' = 30.1\text{m}$ .  $L = 30\text{m}$

and measured length of the survey line = 631.5m

Thus, true length of the survey line =  $\frac{30.1}{30} \times 631.5 = 633.603 \text{ m}$ .                      Ans.

**Problem 2.** *A 20m chain was found to be 4 cm too long after chaining 1400m. It was 8 cm too long at the end of day's work after chaining a total distance of 2420m. If the chain was correct before commencement of the work, find the true distance.*

**Solution**

The correct length of the at commencement = 20m

The length of the chain after chaining 1400m = 20.04 m.

The mean length of the chain while measuring =  $(20+20.04)/2 = 20.02\text{m}$

The true distance for the wrong chainage of 1400m =  $(20.02/20) \times 1400 = 1401.4 \text{ m}$

The remaining distance =  $2420 - 1400 = 1020\text{m}$

The mean length of chain while measuring the remaining distance =  $(20.08+20.04)/2 = 20.06\text{m}$

The true length of remaining 1020m =  $(20.06/20) \times 1020 = 1023.06\text{m}$

Hence, the total true distance =  $1401.4 + 1023.06 = 2424.46 \text{ m}$     Ans.

**Problem No.3.** A line was measured with a steel tape which was exactly 30 meters at 20°C at a pull of 100N (or 10kgf), the measured length being 1650.00 meters. The temperature during measurement was 30° C and the pull applied was 150N (or 15kgf). Find the length of the line, if the cross-sectional area of the tape was 0.025sq.cm. The co-efficient of expansion of the material of the tape per 1 °C =  $3.5 \times 10^{-6}$  and the modulus of elasticity of the material of the tape =  $2.1 \times 10^5$  N/mm<sup>2</sup> ( $2.1 \times 10^6$  kg/cm<sup>2</sup>).

**Solution:**

(i) Correction of temperature per tape length

$$= \alpha(T_m - T_o)L$$

$$= 0.0000035(30 - 20) 30$$

$$= 0.00105\text{m (+ve)}$$

(ii) Correction for pull per tape length

$$= C_P = \frac{(P - P_0) \times L}{(A \times E)} = \frac{(150 - 100) \times 30}{(2.5 \times 2.1 \times 10^5)}$$

$$= 0.00286\text{m (+ve)}$$

$$\text{Combined correction} = 0.00105 + 0.00286 = 0.00391\text{m}$$

$$\text{True length of the tape} = 30 + 0.0039 = 30.0039\text{m}$$

$$\text{True length of the line} = \frac{(30.0039 \times 1650.00)}{30}$$

$$= 1650.21\text{m.}$$

Ans.

## EXERCISE

1. A distance of 2000m was measured by a 30m chain. Later on, it was detected that the chain was 0.1 m too long. Another 500 m (i.e. total 2500 m) was measured and it was detected that the chain was 0.15 m too long. If the length of the chain in the initial stage was quite correct, determine the exact length that was measured.
2. To measure a base line a steel tape 30m long standardized at 15 C with a pull of 100N was used. Find the correction per tape length if the temperature at the time of measurement was 20°C and the pull exerted was 160N, weight of 1 cubic cm of steel is 0.0786N, weight of the tape = 8N.  $E = 2.1 \times 10^5$  kg/sq.cm, Co-efficient of expansion of the tape per 1°C =  $7.1 \times 10^{-7}$ .
3. A tape 100m long, 6.35mm wide, 0.5 mm thick was used to measure a line, the apparent length of which was found to be 1986.96m. The tape was standardized under a pull of 67.5 N, but after the line was measured, it



was found that the pull actually used during the measurement was 77.5 N. What was the true length of the line if the tape was standardized? Take  $E = 200000 \text{ N/mm}^2$ .

## **Chapter-2**

### **CHAINING AND CHAIN SURVEYING**

In addition to chain or tape, several other auxiliary equipment are required in a chain surveying These are listed in subsequent paragraphs.

#### **Arrows**

Arrows or chain pins, as these are called sometime, are made of stout steel wire 4 mm in diameter, 400 to 450 mm long and black enameled. These are used to mark the end of each chain length as shown in Figure (a).

#### **Wooden Pegs**

These are made of stout timber generally 25 to 30 mm square or circular size and 150 mm long as shown in Figure (b). Wooden pegs are normally used to mark station position on ground on a quasi-permanent state. These are tapered at one end so that they can be driven in the ground with a hammer. These are kept at about 40 mm (minimum) projecting above the ground.

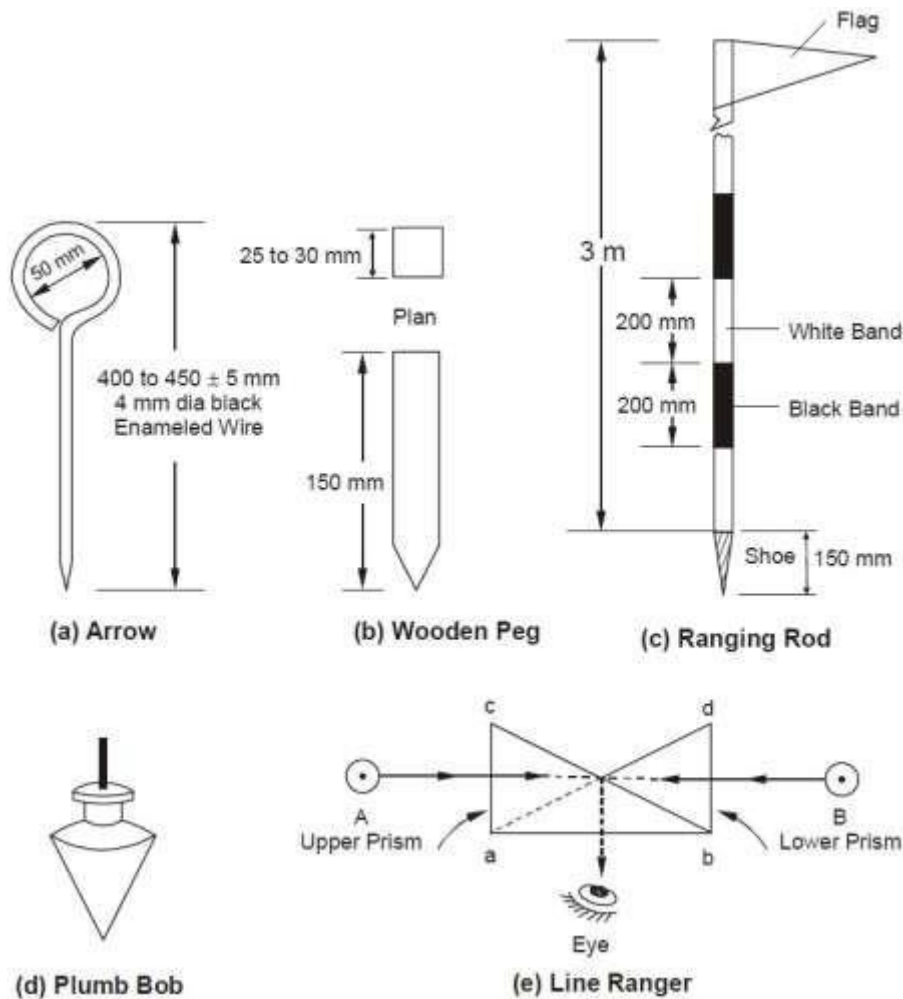

## Ranging Rods

These are octagonal or circular in plan normally 25 to 30 mm diameter straight timber or tubular steel rods, 3 m in length and provided with an iron shoe at lower end as shown in Figure (c). These are painted in black and white alternate bands and normally have a flag at the top for easy recognition and identification from a distance. If the ranging rods are graduated in meters and one tenth of a meter, they are called offset rods and are used for measurement of short offsets.

## Plumb Bob

It is usually heavy spherical or conical ball, as shown in Figure (d), of metal and is used to transfer points on ground by suspending it with the help of a strong thread. It is used in measuring distances on sloping ground by stepping. Compass, Dumpy levels and Theodolites are also positioned over the station point accurately with the help of plumb bobs.

## Line Ranger

A line ranger consists of either two plane mirrors or two right angled isosceles prisms placed one above the other as depicted in Figure (e). The diagonals of both the prisms are silvered so as to reflect the incident rays. Line rangers are provided with a handle to hold the instrument. A line ranger can also be used to draw offset on a chain line.

## **Use of chain**

**Unfolding Of Chain:** To open a chain the strap is unfastened and the two brass handles are held in the left hand and the bunch is thrown forward with the right hand. Then on chainman stands at the starting station by holding one handle and another move forward by holding the other handle until the chain is completely extended.

**Folding of Chain :** After the completion of the work the chain should be folded in to a bundle and fastened with a leather strap. To do this the handles of the chain should be brought together by pulling the chain at the middle. Commencing from the middle, take two pairs of link at a time with the right hand and place them obliquely across the other in the left hand. When the chain is collected in a bundle, it is tied with a leather strap. This process is called the folding of chain.

## **Reading a chain :**

A survey chain is generally composed of 100 or 150 links formed by pieces of galvanised mild steel wire of 4 mm diameter. The ends of each link are looped and connected together by means of three circular or oval shaped wire rings to provide flexibility to chain. The length of each link is measured as the distance between the centres of two consecutive middle rings.

The ends of chain are provided with brass handles with swivel joints. The end link length includes the length of handle and is measured from the outside of the handle, which is considered as zero point or the chain end. Tallies, which are metallic tags of different patterns, are provided at suitably specified points in the chain to facilitate quick and easy reading. A semi-circular groove is provided in the centre on the outer periphery of handle of chain for fixing the mild steel arrow at the end of one chain length. The number of links in a chain could be 100 in a 20 m chain and 150 in a 30 m chain. The details of a metric chain are as shown in Figure

## **Testing of a chain:**

Due to continuous use, a chain may be elongated or shortened. So, the chain should be tested and adjusted accordingly. If full adjustment is not possible, then the amount of shortening (known as 'too short') and elongation (known as 'too long') should be noted clearly for necessary correction applicable to the chain.

For testing the chain, a test gauge is established on a level platform with the help of standard steel tape. The steel tape is standardized at 20°C and under a tension of 8 kg. The test gauge consists of two pegs having nails at the top and fixed on a level platform a required distance apart (say 20 or 30m). The incorrect chain is fully stretched by pulling it under normal tension along the test gauge. If the length of the chain does not tally with standard length, then the attempt should be made to rectify the error. Finally the amount of elongation or shortening should be noted.

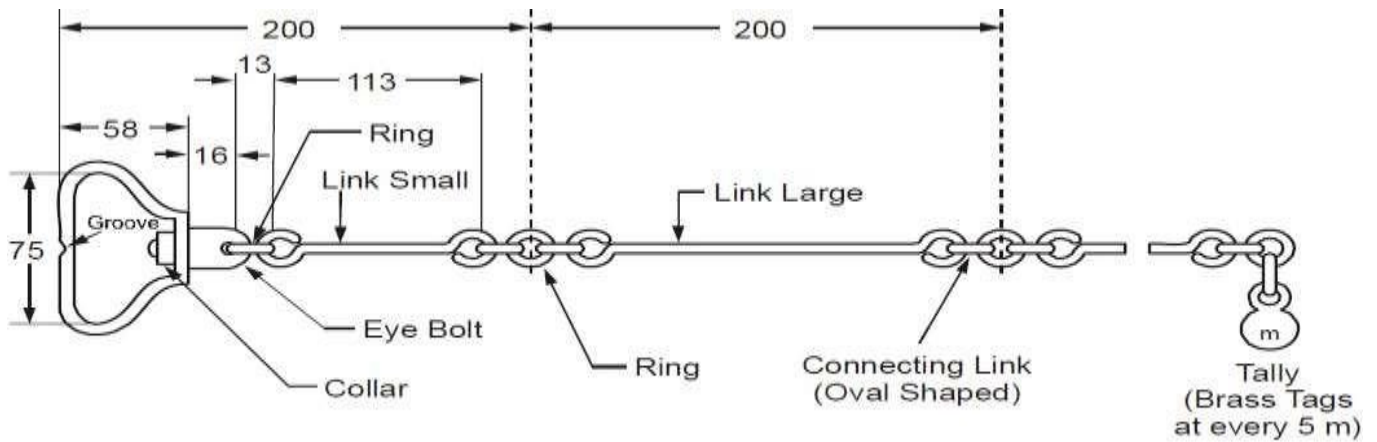

**Details of Metric Chain**

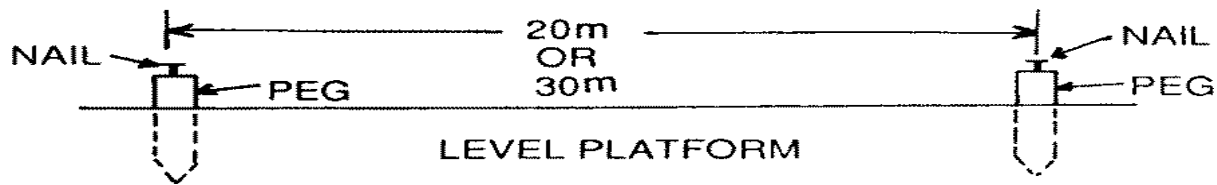

The allowable error is about 2mm per 1m length of the chain. The overall length of the chain should be within the following permissible limit:

20 m chain:  $\pm 5\text{mm}$

30m chain:  $\pm 8\text{mm}$

### **Adjustment of a chain:**

Chains are adjusted in the following ways :

- When the chain is too long, it is adjusted by :
  - Closing the opened joints of the rings.
  - Reshaping the elongated rings.
  - Removing one or more circular rings.
  - Replacing the worn-out rings.
  
- When the ring is too short, it is adjusted by:
  - Straightening the bent links.
  - Flattening the circular rings.
  - Inserting the new rings where necessary.
  - Replacing the old rings by some larger rings.

### **Ranging:**

The process of establishing intermediate points on a straight line between two end points is known as ranging.

**Purpose of ranging:**

The purpose of ranging is to mark a number of intermediate points on a survey line joining two stations in the field so that the length between them may be measured correctly.

If the line is short or its end station is clearly visible, the chain may be laid in true alignment. But if the line is long or its end station is not visible due to undulation ground, it is required to mark a number of points with ranging rods.

**Code of Signals for Ranging**

Sl.No.	Signal by the Surveyor	Action by the Assistant
1	Rapid sweep with right hand	Move considerably to the right
2	Slow sweep with right hand	Move slowly to the right
3	Right arm extended	Continue to move to the right
4	Right arm up and moved to the right	Plumb the rod to the right
5	Rapid sweep with left hand	Move considerably to the left
6	Slow sweep with left hand	Move slowly to the left
7	Left arm extended	Continue to move to the left
8	Left arm up and moved to the left	Plumb the rod to the left
9	Both hands above head and then brought down	Correct
10	Both arms extended forward horizontally and the hands depressed briskly	Fix the rod

**Direct ranging:**

When intermediate ranging rods are fixed along the chain line, by direct observation from either end station, the process is known as “Direct Ranging”. Direct ranging is possible when the end stations are inter visible. The following procedure is adopted for direct ranging:

- Erect ranging rods or poles vertically behind each end of the line.
- Stand about 2m behind the ranging rod at the beginning of the line.
- Direct the assistant to hold a ranging rod vertically at arm’s length at the point where the intermediate station is to be established.
- Direct the assistant to move the rod to the right or left , until the ranging rods appear to be exactly in a straight line.
- Stoop down and check the position of the rod by sighting over their lower ends in order to avoid error to non-vertically of the ranging rods.
- After ascertaining that the ranging rods are in a straight line, signal the assistant to fix the ranging rod.

**Indirect ranging:**

When the end stations are not inter visible due to there being high ground between them, intermediate ranging rods are fixed on the line in an indirect way. This method is known, as indirect ranging or reciprocal ranging. The following procedure is adopted for indirect ranging.

Suppose A and B are two end stations which are not intervisible due to high ground existing between them. Suppose it is required to fix intermediate points between A and B. Two chain men take up positions at  $R_1$  and  $S_1$  with ranging rods in their hands. The chainman at  $R_1$  stands with his face towards B so that he can see the ranging rods at  $S_1$  and B. Again the chainman at  $S_1$  stands with his face towards A so that he can see the ranging rods at  $R_1$  and A. Then the chainmen proceed to range the line by directing each other alternately. The chainman at  $R_1$  direct the chainman at  $S_1$  to come to position  $S_2$  so that  $R_1, S_2$  and B are in the same straight line. Again the chainman at  $S_2$  directs the chainman at  $R_1$  to move the position at  $R_2$  so that  $S_2, R_2$  and A are in the same straight line. By directing each other alternately in this manner, they change their positions every time until they finally come to the positions R and S, which are in the straight line AB. This means the points A, R, S and B are in the same straight line.

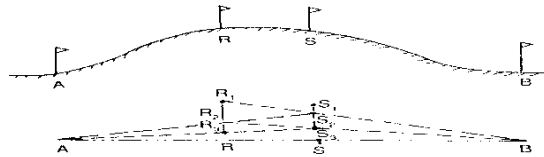

### Role of Leader and Follower :

The chainman at forward end of the chain, who drag the chain forward, is known as leader. The duties of the leader are as follows:

- a. To drag the chain forward with some arrows and a ranging rod.
- b. To fix arrows on the ground at the end of every chain.
- c. To obey the instructions of the follower.

The chainman at the rear end of the chain, who holds the zero end of the chain at the Station, is known as the follower. The duties of the follower are:

- a. To direct the leader at the time of ranging.
- b. To carry the rear handle of the chain.
- c. To pick up the arrows inserted by the leader.

### Chaining on Level Ground :

Before starting the chaining operation two ranging rods should be fixed on the chain line, at the end stations. The other ranging rods, should be fixed near the end of each chain length, during the ranging operation.

To chain the line, the leader moves forward by dragging the chain and by taking with him a ranging rod and 10 arrows . The follower stands at the starting station by holding the other end of chain. When the chain is fully extended , the leader holds the ranging rod vertically at arm's length. The follower directs the leader to move his rod to the left or right until the ranging rod is exactly in line. Then the follower holds the zero end of the chain by touching the station peg. The leader stretches the chain by moving it up and down with both hands, and finally places it on the line. He then inserts an arrow on the ground at the end of the chain and marks with a cross ( X ).

Again, the leader moves forward by dragging the chain with nine arrows and the ranging rod. At the end of the chain, he fixes another arrow as before. As the leader moves further, the follower picks up the arrows which were inserted by the leader. During chaining the surveyor or an assistant should conduct the ranging operation.

In this way, chaining is continued. When all the arrows have been inserted and the leader has none left with him, the follower hands them over to the leader; this should be noted by the surveyor. To measure the remaining fractional length, the leader should drag the chain beyond the station and the follower should hold the zero end of the chain at the last arrow. Then the odd links should be counted.

### **Chaining on Sloping Ground:**

Chaining on the surface of a sloping ground gives the sloping distance. For plotting the surveys, horizontal distances are required. It is therefore, necessary either to reduce the sloping distance to horizontal equivalent or to measure the horizontal distances between the stations directly. The following are the different methods that are generally employed.

- a) Direct Method or Stepping Method
- b) Indirect Method

### **Direct Method:**

This method is applied when slope of the ground is very steep. In this method, the sloping ground is divided in to a number of horizontal and vertical strips, like steps. So, this method is also known as stepping method. The length of the horizontal portions are measured and added to get the total horizontal distance between the points. The steps may not be uniform, and would depend on the nature of the ground.

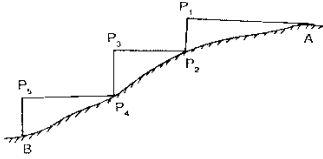

## Procedure:

Suppose the horizontal distance between points A and B is to be measured.

The line AB is first ranged properly.

Then, the follower holds the zero end of the tape at A.

The leader selects a suitable length  $AP_1$  so that  $P_1$  is at chest height and  $AP_1$  is just horizontal.

The horizontal is maintained by eye estimation, by tri-square or by wooden set-square.

The point  $P_2$  is marked on the ground by plumb-bob so that  $P_1$  is just over  $P_2$ .

The horizontal length  $AP_1$  is noted then the follower moves to the position  $P_2$  and holds the zero end of the tape at that point.

Again the leader selects a suitable length  $P_2P_3$  in such a way that  $P_2P_3$  is horizontal and  $P_3P_4$  vertical.

Then the horizontal lengths  $P_2P_3$  and  $P_4P_5$  are measured.

So the total horizontal length,  $AB = AP_1 + P_2P_3 + P_4P_5$

## Indirect Method :

When the slope of the ground surface is long and gentle, the stepping method is not suitable. In such a case, the horizontal distance may be obtained by the indirect methods. Those are of following types.

- By measuring the slope with clinometers.
- By applying hypotenusal allowance
- By knowing the difference of level between the points.

## Measuring slope with a clinometer :

A clinometer is a graduated semicircular protractor. It consists of two pins  $P_1$  and  $P_2$  for sighting the object. A plumb bob is suspended from point O with a thread. When the straight edge is just horizontal, the thread passes through  $0^\circ$ . When the straight edge is tilted, the thread remains vertical, but passes through a graduation on the arc which shows the angle of slope.



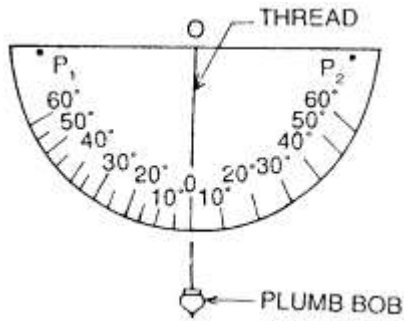

Suppose C and D are two points on sloping ground. Two ranging rods are fixed at these points. Then two other points C<sub>1</sub> and D<sub>1</sub> are marked on the ranging rods so that CC<sub>1</sub> = DD<sub>1</sub>

The clinometer is placed in such a way that its centre just touches the mark C<sub>1</sub>. The clinometer is then inclined gradually until the points P<sub>1</sub>, P<sub>2</sub>, and D<sub>1</sub> are in the same straight line. At this position the thread of the clinometer will show an angle which is the angle of slope of the ground. Suppose this angle is  $\alpha$ . The sloping distance CD is also measured.

The required horizontal distance = CB =  $l \cos \alpha$

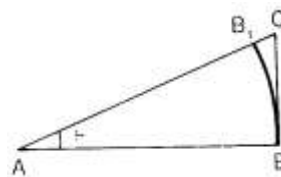
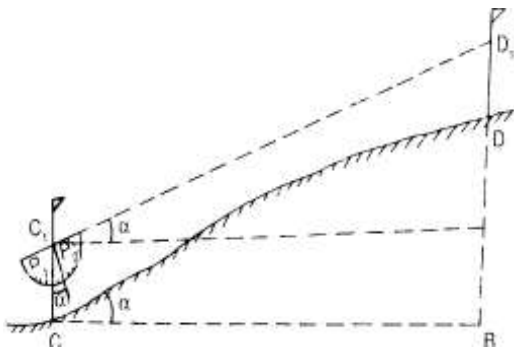

#### a. Applying hypotenusal allowance

In this method, the slope of the ground is first out by using the clinometer. Hypotenusal allowance is then made for each tape length.

Let  $\theta$  = angle of slope measured by clinometer

$$AB = AB_1 = 20\text{m} = 100 \text{ links}$$

$$AC = AB \sec \theta = 100 \sec \theta$$

$$B_1C = AC - AB_1$$

$$= 100 \sec \theta - 100$$

$$= 100 (\sec \theta - 1)$$

**Obstacle:**

A chain line may be interrupted the following situations:

1. When chaining is free, but vision is obstructed.
2. When chaining is obstructed, but vision is free, and
3. When chaining and vision are both obstructed

### 1. Chaining free but vision obstructed:

Such a problem arises when a rising ground or a jungle area interrupts the chain line. Here the end stations are not inter-visible.

Case – I

The end stations may be visible from some intermediate points on the rising ground. In this case, reciprocal ranging is resorted to, and the chaining is done by stepping method.

Case – II

The end stations are not visible from intermediate points when jungle are comes across the chain line.

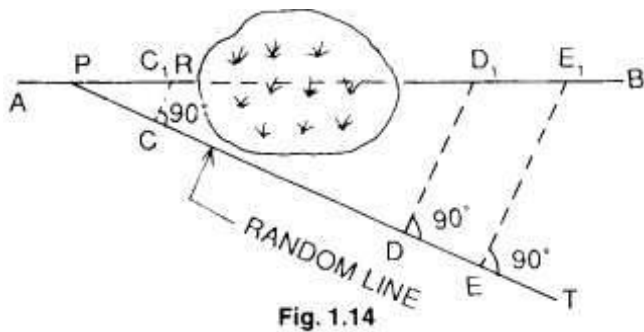

Let **AB** line be the actual chain line which can not be ranged and extended because of interruption by a jungle. Let line extended up to **R**. A point **P** is selected on the chain line and a random line **PT** is taken in a suitable direction. Points **C**, **D** and **E** are selected on the random line and perpendiculars are projected from them. The perpendicular at **C** meets the line at **c<sub>1</sub>**

Theoretically,

$$\frac{DD_1}{PD} = \frac{CC_1}{PC}$$

$$DD_1 = \frac{CC_1}{PC} \times PD \dots\dots\dots (1)$$

Again from triangle **PEE<sub>1</sub>** and **PCC<sub>1</sub>**

$$\frac{EE_1}{PE} = \frac{CC_1}{PC}$$

$$EE_1 = \frac{CC_1}{PC} \times PE \dots \dots \dots (2)$$

From eq 1 and 2, the lengths **DD<sub>1</sub>** and **EE<sub>1</sub>** are calculated. The distance is measured along the perpendiculars at **D** and **E**. Points **D<sub>1</sub>** and **E<sub>1</sub>** should lie in the chain line **AB**

$$\text{Distance } PE_1 = \sqrt{PE^2 + E^2_1}$$

### 2. Chaining obstructed but vision free:

Such a problem arises when a pond or river comes across the chain line. The stations may be tackled in the following ways.

Case – I

When a pond interrupts the chain line, it is possible to go around the obstruction.



$$CD = EF$$

$$CD = \sqrt{ED^2 + CE^2}$$

### 3. Chaining and vision both obstructed :

Such a problem arises when a building comes across the chain line. It is solved in the following manner.

Suppose **AB** is the chain line. Two points **C** and **D** are selected on it at one side of the building. Equal perpendiculars **CC<sub>1</sub>** and **DD<sub>1</sub>** are erected. The line **C<sub>1</sub>D<sub>1</sub>** is extended until the building is crossed. On the extended line, two points **E<sub>1</sub>** and **F<sub>1</sub>** are selected. Then perpendiculars **E<sub>1</sub>E** and **F<sub>1</sub>F** are so erected that

$$E_1E = F_1F = D_1D = C_1C$$

Thus, the points **C**, **D**, **E** and **F** will lie on the same straight line **AB**

Here,  $DE = D_1E_1$

The distance  $D_1E_1$  is measured, and is equal to the required distance  $DE$ .

**Problem :**

A chain line  $ABC$  crosses a river,  $B$  and  $C$  being on the near and distant banks respectively. The line  $BM$  of length  $75\text{ m}$  is set out at right angles to the chain line at  $B$ . If the bearings of  $BM$  and  $MC$  are  $287^\circ 15'$  and  $62^\circ 15'$  respectively, find the width of the river.

**Solution :**

$\angle BMC = \text{BB of } BM - \text{FB of } MC$   
 i.e.  $\alpha = (287^\circ 15' - 180^\circ 00') - 62^\circ 15' = 45^\circ 00'$   
 From triangle  $MBC$ ,  $\frac{BC}{BM} = \tan 45^\circ 00'$   
 $BC = BM \tan 45^\circ 00' = 75\text{ m}$   
 So the width of river is  $75\text{ m}$ .

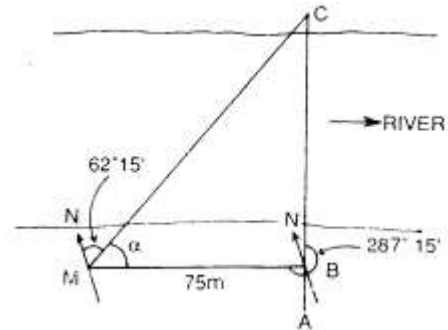

**CHAIN SURVEYING**

**Definition:**

The chain surveying is one of the method of land surveying. It is the system of surface in which sides of different triangular are measured directly in the field and no angular measurement are taken.

**Principle of Chain Surveying:**

The principle of chain surveying is triangulation. This means that the area to be surveyed is divided in to a number of small triangles which should be well conditioned. In chain surveying the sides are directly measured by chain or tape.

Chain surveying is recommended when:

1. The ground surface is more or less leveled.
2. A small area is to be surveyed.
3. A small – scale map is to be prepared and
4. The formation of well conditioned triangles is easy

Chain surveying is unsuitable when:

1. The area is crowded with many details.
2. The area consists of too many details.
3. The area is very large.
4. The formation of well – conditioned triangles becomes difficult due to obstacles.

### Well Conditioned Triangle:

1. A triangle is said to be well – conditioned when no angle is less than  $30^\circ$  or greater than  $120^\circ$ . An ideal triangle is considered to be best conditioned or ideal triangle.
2. Well conditioned triangles are preferred because their apex points are very sharp and can be located by single ‘dot’.

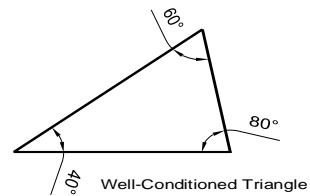
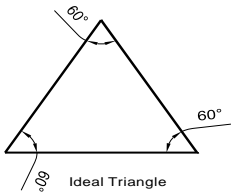

### ILL – Conditioned Triangle:

1. A triangle in which an angle is less than  $30^\circ$  and greater than  $120^\circ$  is said to be ill-conditioned triangle.
2. Ill conditioned triangles are not used in chain surveying.

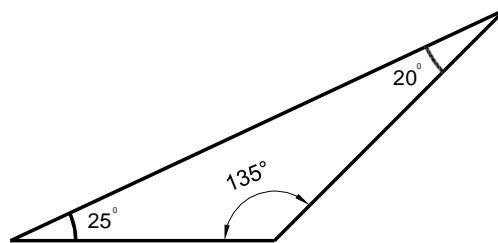

## Accessories in chain survey

The following equipments are required for conducting chain survey:

1. Metric chain (20 m)	= 1 no
2. Arrows	= 10 nos
3. Metallic tape (15m)	= 1 no
4. Ranging rods	= 3 nos
5. Offset rod	= 1 no
6. Clinometer	= 1 no
7. Plumb bob with thread	= 1 no
8. Cross staff or optical square	= 1 no
9. Prismatic compass with stand	= 1 no
10. Wooden pegs	= 10 nos
11. Mallet	= 1 no
12. Field book	= 1 no
13. Good pencil	= 1 no
14. Pen knife	= 1 no
15. Eraser	= 1 no

## Reconnaissance Survey and Index Sketch:

During reconnaissance survey, the surveyor should walk over the area and note the various obstacles and whether or not the selected stations are inter-visible. The main station should be so selected that they enclose the whole area. The surveyor should be take care that the triangles formed are well-conditioned.

The neat hand sketch of the area which is prepared during reconnaissance survey is known as “index sketch” or “key plan”. The index sketch shows the skeleton of survey work.

## Selection of Surveying Stations:

Survey stations are the points at the beginning and the ending of a chain line. The stations are classified under 3 categories

- i.e* - (a) Main Station  
 (b) Subsidiary Station  
 (c) Tie Station

1. Main survey station at the end of chain line should be inter-visible.
2. Survey line should be minimum as possible.
3. The main principle of surveying such as working from whole to part and from part to whole.
4. The stations should be well conditioned triangle.
5. Every triangle should be provided with a check line.
6. Tie line should be provided to avoid too long offsets.
7. Obstacles to ranging and changing if any should be avoided.

The larger side of the triangle should be placed parallel to the boundaries, roads, buildings, etc. to have short offsets.

1. Chain line should be lie over leveled ground.
2. Line should be laid on one side of the road to avoid disturbance of chaining by passing of traffic.

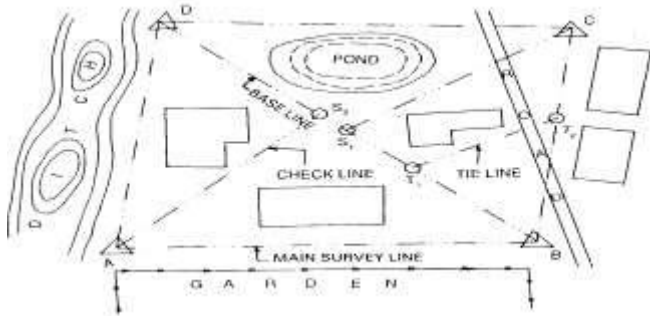

INDEX SKETCH

**Base line:**

The line on which the frame work of the survey is built is known as the “Bas

**Tie line:**

The tie line is a line which joins subsidiary stations on the main line.

**Check line:**

The line joining the apex point of triangle to some fixed point on its base is known as check line. It is taken to check the accuracy of the triangle.

**offset:**

The lateral measurement taken from an object to known as offset. Offsets are taken to locate objects with chain line. They are two types:

- I. Perpendicular Offset
- II. Oblique Offset

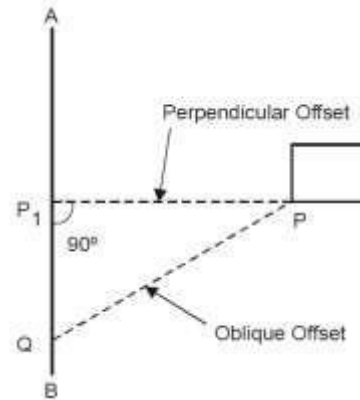

the chain line is reference to the

**Perpendicular Offset:**

When the lateral measurement for fixing the detail points are maid perpendicular to the chain line. The offsets are known as perpendicular offset.

## Oblique Offset:

When the lateral measurement for fixing the detail points are made at any angle to the chain line. The offsets are known as oblique offset. It can be done by following two(2) process

*i.e -*

- a. Long offset
- b. Short offset

## Setting offset with chain and tape (Manual methods)

### 3-4-5 Offset

Perpendicular offset of chain line at any point A is obtained using the following mathematical expression ( $3^2 + 4^2 = 5^2$ ). A point B is located on chain line at a distance of

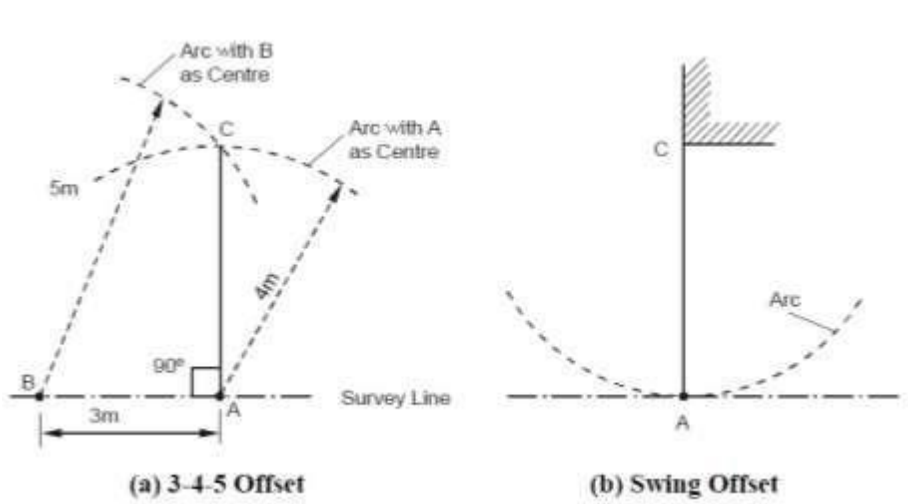

3 m from A such that  $AB = 3$  m. Next, an arc is set on ground with centre at A and radius equal to 4 m. Another arc is laid with center at B and radius equal to 5 m intersecting the previous arc at C as shown in Figure (a). Line AC will then be perpendicular to line AB.

### Swing Offset

The perpendicular distance of an important feature, e.g. building corner, from the chain line is measured using swing offset method. The zero end of tape is kept at point of interest (Figure (b)) and point A (i.e. normal from C on chain line) is located by swinging the tape with C as center. The point A is characterized by a point at which the arc generated by swing is tangential to survey line and the distance of C from any point on chain line is minimum.

It may be noted that usually only small offsets can be set by manual methods.



## Optical Square:

1. It is a most suitable instrument for setting out a line at a right angle to another line.
2. It consists of a circular metal box about 5c.m. in diameter and 1.25c.m. in deep. It consists of two inclined mirrors at an angle of  $45^{\circ}$ .
3. The upper glass is known as *horizontal* glass and the lower end glass is known as *index* glass.

### Principle:

If the two mirrors are inclined with the surface at an angle of  $45^{\circ}$ . The plane is successfully reflected under deviation of twice the angle.

### Uses:

1. It is used to find out foot of perpendicular to the chain line.
2. To set out a perpendicular to a chain line.

## Cross staff:

The cross-staff consists of four metal arms with vertical slits. The two pairs of arms are at right angles to each other. The vertical slits are meant for ranging rods. The cross-staff is mounted on a wooden pole of length 2.5c.m. The pole is fitted with an iron shoe.

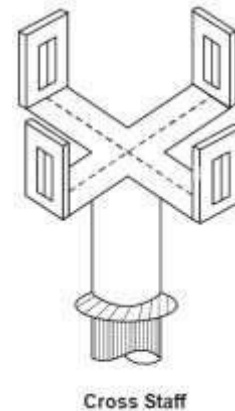

The two pairs of sighting the 1.5m. and diameter

## Limiting Length of Offset:

The maximum length of the offset should not be more than the length of the tape used in the survey. Generally, the maximum length of offset is limited to 15 m. however, this length also depends upon the following factors:

- (a) The desired accuracy of the map
- (b) The scale of the map
- (c) The maximum allowance deflection of the offset from its true direction
- (d) The nature of ground

## Sources of Errors :

Errors may arise from three sources :

### (1) Instrumental

Error may arise due to imperfection or faulty adjustment of the instrument with which measurement is being taken. For example, a tape may be too long or an angle measuring instrument may be out of adjustment. Such errors are known as instrumental errors.

### (2) Personal

Error may also arise due to want of perfection of human sight in observing and of touch in manipulating instruments. For example, an error may be there in taking the level reading or reading an angle on the circle of a theodolite. Such errors are known as personal errors.

### (3) Natural

Error may also be due to variations in natural phenomena such as temperature, humidity, gravity, wind, refraction, and magnetic declination. If they are not properly observed while taking measurements, the results will be incorrect. For example a tape may be 20 metres at 20<sup>0</sup>C but its length will change if the field temperature is different.

## Field Book:

1. The book in which the chain or tape measurements are entered or sketched of detail points are recorded is called field book.
2. Its size is 20c.m.X 12c.m.
3. The chain line may be represented about 1.5c.m. to 2.0c.m. a part rolled down the middle of each page.
4. The chain line is started from the bottom of page and work up words.
5. It should be well bounded and a size of convenient for the pocket.
6. All distance along the chain line are entered either to the left or to the right of the chain line.
7. The new line should be started from a new fresh page and name of line should be noted at the foot and booking proceeds from the bottom of the page to up wards.
8. At the different feature within the offset are reached, surveyor draw them and enters the chain and length of each offset.
9. Field books may be two types
  - I. Single Line
  - II. Double Line

## **Single-Line Field Book**

In this type of field book , a single red line is drawn through the middle of each page. This line represents the chain line and the chainages are written on it. The offsets are recorded with sketches to the left or right of the chain line.

## **Double-Line Field Book**

In this type of field book, two red lines, 1.5 cm apart, are drawn through the middle of each page. This column represents the chain line, and the chainages are written in it. The offsets are recorded with sketches to the left or right of this column.

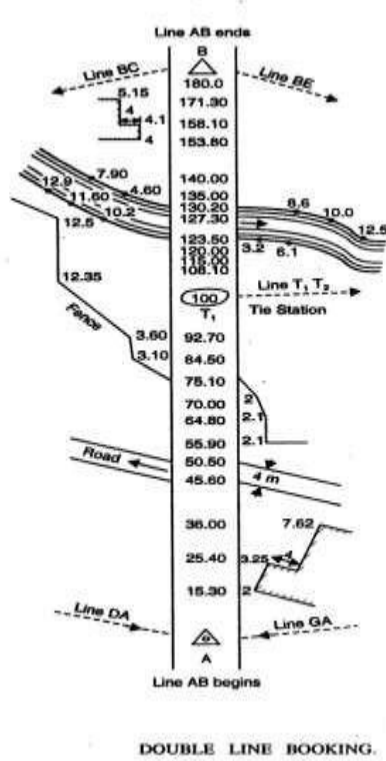
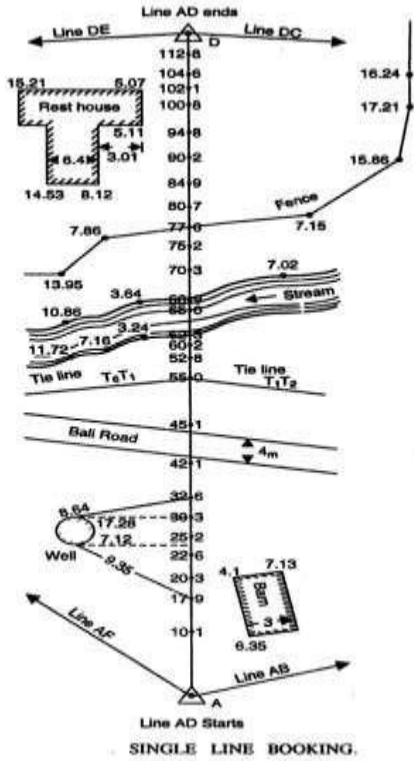

## EQUIPMENTS OF PLOTTING:

Following are the equipments of plotting

1. Drawing board ( normal size – 1000 mm X 700 mm)
2. Tee – Square
3. Set – square ( $45^{\circ}$  and  $60^{\circ}$ )
4. Protractor
5. Cardboard Scale
6. Instrument box
7. Drawing sheets

## Procedure for plotting:

1. A suitable scale is chosen so that the area can be accommodated in the space available in the map.
2. A margin of about 2 cm. from the edge of the sheet is drawn around the sheet.
3. The north line marked on the right-hand corner, and should perfectly be vertical. When it is not convenient to have a vertical north line, it may be inclined to accommodate the whole area within the map.

4. The framework is completed with all survey lines, check lines and tie lines. If there is some plotting errors which exceeds the permissible limits, the incorrect lines should be resurveyed.
5. The plotting of offsets should be continued according to the sequence maintained in the field book.
6. The conventional symbols are used in the map should be shown on the right – hand side.
7. The scale of the map is drawn below the heading or in some suitable space. The heading should be written on the top of the map.
8. Unnecessary lines, objects, etc. should be erased.
9. The map should not contain any dimensions.

**Recommended scales for some of the types of map could be**

(a) **Geographical Maps** :1/25000 to 1/100000 and even smaller. Atlas maps and wall maps could even have smaller scales.

(b) **Topographical Maps** :1/25000 to 1/250000 showing natural and man-made features and contours.

(c) **Cadastral or Land Revenue Maps** :1/500 to 1/5000, relatively larger scales showing holdings of individuals. Used for tax/revenue collection and for planning and management.

(d) **Building Sites, Town Planning Schemes etc.** :1/5000 to 1/10000, for building sites larger scale, e.g. 1/1000 can be used.

(e) **Roads, Railway Lines or Canal Maps** :Longitudinal sections can be drawn to a horizontal scale of 1/1000 to 1/20000 while for vertical plots the scales are 1/100 to 1/200. For plotting cross sections, both horizontal and vertical scales are 1/100 to 1/200.

It can be noted that on many maps with smaller scales, many important land features cannot be plotted to scale. However, these, being important details, cannot be ignored. Hence, these are represented on map sheet by suitable conventional symbols.

**Some of the conventional symbols approved by Bureau of Indian Standard (BIS) are as shown in Figure.**

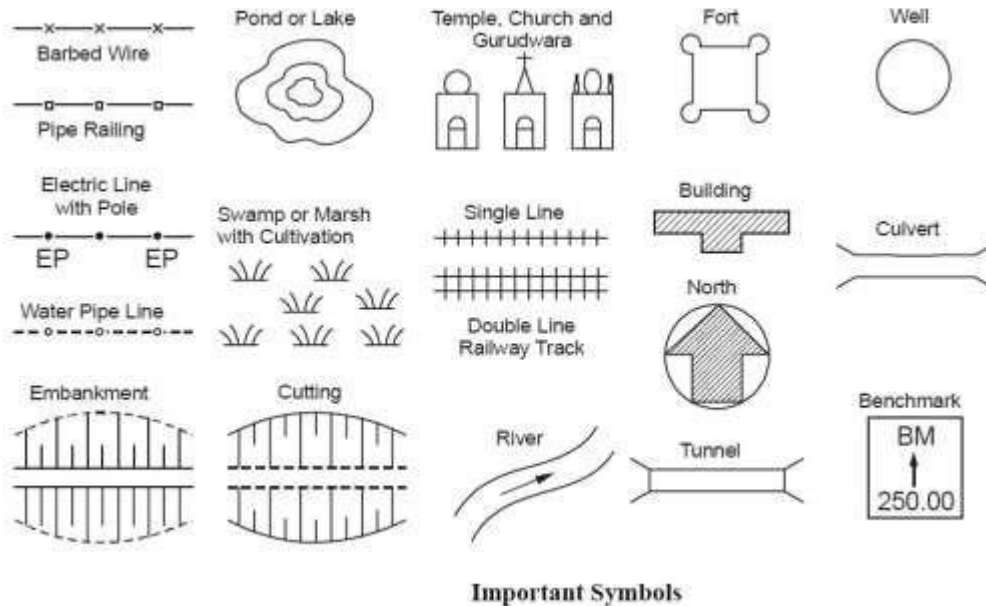

## ERRORS IN CHAIN SURVEYING:

Errors in chaining may be caused due to variation in temperature and pull, defects in instruments, etc. They may be either;

1. Compensating Error
2. Cumulative Error

### Compensating Error:

Errors which may occur in the both directions (i.e. both positive and negative) and which finally tend to compensate are known as compensating errors. They are proportional to  $\sqrt{L}$ , where  $\sqrt{L}$  is the length of the line. Such error may be caused by

1. Incorrect holding of the chain.
2. Inaccurate measurement of right angles with chain, tape.
3. Horizontality and verticality of steps not being properly maintained during the stepping operations.
4. Fractional parts of the chain or tape not being uniform throughout its length

### Cumulative Error:

Errors which may occur in the same direction and which finally tend to accumulate. They seriously affect the accuracy of work, the length of the line (L).

**Positive Error:** when the measured length is greater than the actual length, (the chain length is too short), the error is said to be positive error. Such error occurs due to:

- (a) The length of chain or tape being shorter than the standard length.

- (b) Slope correction not being applied.
- (c) Correction for sag not being made.
- (d) Measurement being taken with faulty alignment.
- (e) Measurement being taken in high winds with the tape in suspension.

**Negative Error:** When the measured length is less than the actual length,(the chain length is too long), the error is said to be negative . These errors occur when length of chain or tape is greater than the standard length due the following reasons :

- (a) The opening of ring joints.
- (b) The applied pull being much greater than the standard.
- (c) The temperature during measurement being much higher than standard.
- (d) Wearing of connecting rings.
- (a) Elongation of the links due to heavy pull.

### **Precautions against Error:**

Following are the precautions should be taken to guard against errors and mistakes.

1. The point where the arrow is fixed on the ground should be marked with a cross (X).
2. The zero end of the chain or tape should be properly held.
3. The chain man should call the measurement loudly and distinctly and the surveyor should repeat them while booking.
4. During chaining , the number of arrows carried by the follower and leader should always tally with the total numbers of arrows taken.
5. Measurements should not be taken with tape in suspension in high wind.
6. In stepping operations, horizontality and verticality should be properly maintained.
7. Ranging should be done accurately.
8. No measurement should be taken with the chain in suspension.
9. Care should be taken so that the chain is properly extended.

## **CHAPTER-3**

### **ANGULAR MEASUREMENT AND COMPAS SURVEYING**

## **ANGULAR MEASUREMENT:-**

### **Compass:**

The compass works on the principle that a freely suspended magnetic needle takes the direction of the magnetic lines of force at a place. This provides us a reference direction with respect to which all angles can be measured.

There are two types of compasses

1. The prismatic compass
2. The surveyor's compass.

The surveyor's compass is rarely used in comparison purposes. The principle of the operation of both the compass is the same but they are made differently used in the field

### **1) The prismatic compass.**

It is the most suitable type of surveying compass which consists of a circular box about 100 mm in diameter.

It can be used as a hand instrument or on a tripod.

It can be accurately centered over ground station marks.

The main parts of a prismatic compass is as follows

### **Magnetic Needle:**

The magnetic needle is the most important of the measurement. The needle, generally of the board form, is supported on a hard, steel pivot with an agate tip. When not in use, the needle can be lifted off the pivot, by a lifting needle, actuated by the folding of the objective vane. This is done to ensure that the pivot tip is not subjected to undue wear. The magnetic needle should be perfectly symmetrical and balanced at its midpoint on the hard pointed pivot. It should be weighted with an adjustable weight to compensate for the dip angle. The needle should be sensitive and take up the north-south direction speedily. The needle should lie in the same horizontal plane as the pivot point, and a vertical plane should be made in such a way that the centre of gravity of the needle lies as much below the pivot point as possible.

### **Graduated ring:**

An aluminum graduated ring 85 to 110 mm diameter is attached to the needle on its top a diametrical arm of the ring. Aluminum, being a non-magnetic substance, is used to ensure that the ring does not influence the behavior of the needle. The graduation of the ring is from 0 to 360°. 0°/360° is marked on the south end of the needle and the graduation goes in a clockwise direction, with 90° marked on the west, 180° on the north, and 270° on the east directions. The graduations are marked to half degrees, but it is possible to read the angle as per least count. The graduations on the ring are inverted as they are to be read by a prism.



### **Eye vane prism:**

The point on the prismatic compass from where the straighting is done is known as the eye vane, which is made up of a rectangular frame to the graduated ring when it is folded over the glass plate cover of the compass. The prism has convex surfaces, which magnify the graduations on the ring. A metal cover is used to cover the reading face of the prism when it is not in use. The prism can be raised or lowered on the metal frame for adjusting to the eye of the observer. Dark glasses may be provided on the frame, which can be brought in view while sighting bright objects to reduce glare.

### **Object vane:**

Diametrically opposite the eye vane the object vane, which is a metal frame hinged at the bottom for folding over the glass cover when it is not in use. A fine silk thread or hair is shifted on the frame vertically, which can be used to bisect a ranging rod or the hair is fitted on the frame vertically, which can be used to bisect a ranging rod or other objects. When the frame is folded over the glass cover, it presses against a pin, which actuates the lifting lever of the needle and lifts the needle off the pivot. Also fitted below this frame on the box is a brake pin, which, when gently passed, stops the oscillation of the needle by pressing against the graduated aluminium ring. The object vane may be provided with mirrors, which can be moved over the frame for sighting objects at a height or far below.

### **Compass Box:**

The needle and other fittings are enclosed in a metal box with a glass cover to prevent dust. The two vanes are also attached to the box at diametrically opposite ends. The box is attached to a metal plate through a ball and socket arrangement for leaving the compass. While the compass may also be used by holding it in the hand, it is preferable to use it with a tripod, for which the metal plate has a screwed end that can be attached to a tripod. The compass box can be carried in a leatherpouch when not in use.

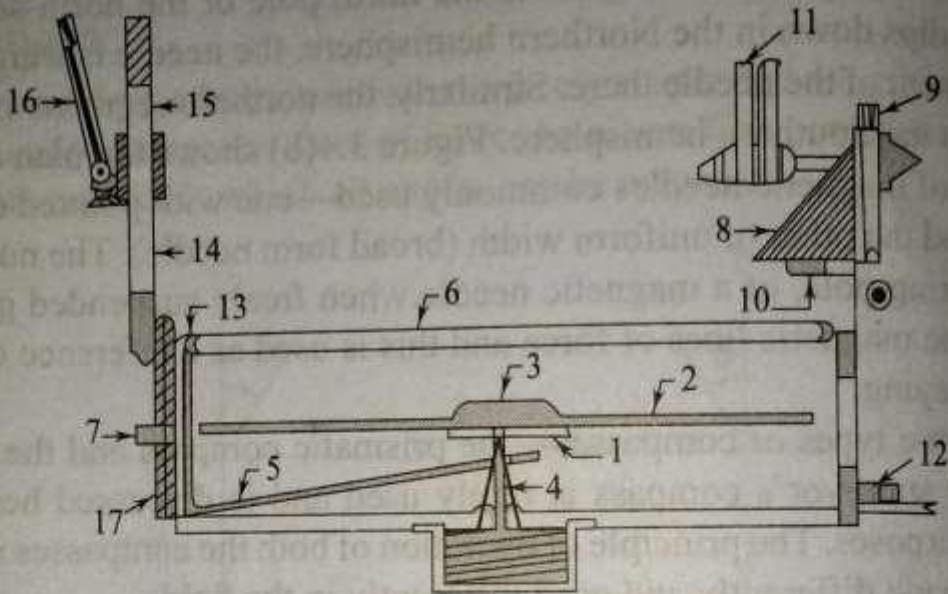

- |                 |                  |             |                            |
|-----------------|------------------|-------------|----------------------------|
| 1 Needle        | 2 Aluminium ring | 3 Agate cap | 4 Pivot                    |
| 5 Lifting lever | 6 Glass cover    | 7 Brake pin | 8 Prism                    |
| 9 Eye vane      | 10 Prism cover   | 11 Sunglass | 12 Focusing knob for prism |
| 13 Lifting pin  | 14 Object vane   | 15 Hair     | 16 Mirror                  |
| 17 Box          |                  |             |                            |

(a) Details of a prismatic compass

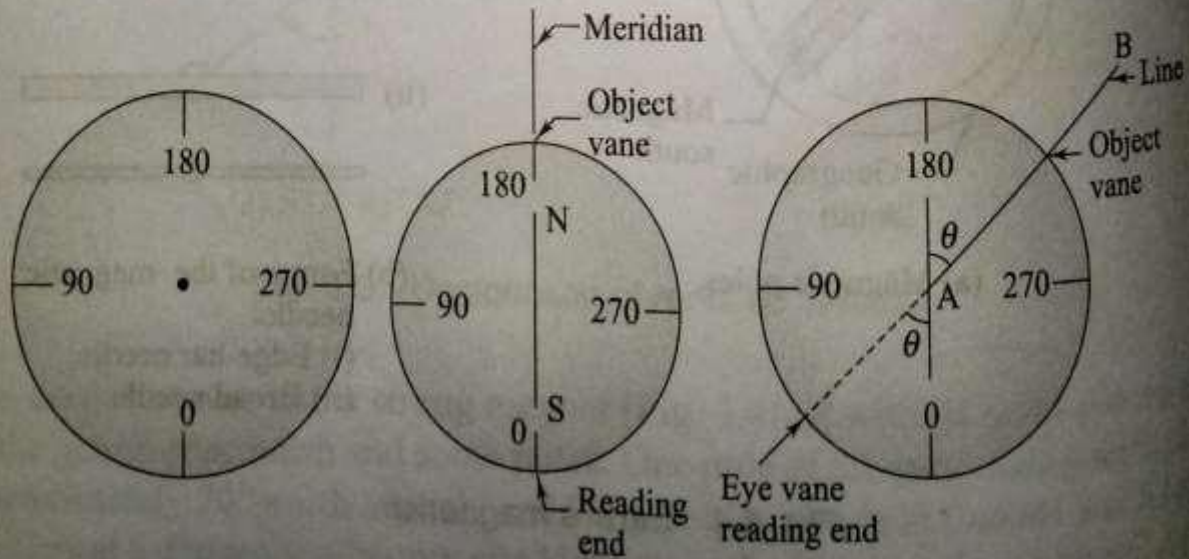

(b) Graduations on the ring

(c) Reading of a bearing

## **Use of Prismatic Compass:**

The following steps are required in using prismatic compass.

1. Setting up and centering screw the prismatic compass onto the tripod and place the tripod over the station. it is centered over the tripod. Centering is done by adjusting the tripod legs.
2. Level the compass using the ball and socket arrangement. Levelling is done approximately so that the needle can move freely in a plane, after opening the objective and eye vanes.
3. Open the object vane and eye vane see that needle moves freely. Direct the object vane towards the ranging rod or any other objects at the next station. Sighting is done by bisecting the object with the cross hair on the object vane while looking through the eye vane. The prism of the eye vane has to be adjusted for a clear view of the graduations by moving it up or down. It is clear that the graduated ring along with the attached needle always points to the north direction while the box is rotated with the vanes. The line of sight between the stations is through the eye vane and the cross hair of the object vane and should pass through the centre of the pivot.
4. Once the object has been clearly sighted, damp the oscillation of the needle with the damping pin if required. Once the object has been pin if required. Once the needle comes to rest, looking through the prism, record the reading at the point on the ring corresponding to the vertical hair seen directly through the slit in the prism holder.

### **Graduation on ring:**

It is clear from the graduations that the prismatic compass gives the WCBs of the lines. The reading taken through the prism has to be zero when the lines. The reading taken through the prism has to be zero when the line of sight is pointing to the north. The reading end is the south end of the needle. Therefore, the zero graduation is marked at the south end .

### **Temporary adjustments:**

At every station where prismatic compass is placed, The following adjustments, as described above, have to be made: centering leveling, and focusing the prism. The prism has to be focused once if the same person has to take the prism. The prism has to be focused only once if the same person has to take the readings. Centering is done by adjusting only the legs to bring the compass exactly over the station. Leveling is done to ensure that as the compass is rotated it moves very nearly in a horizontal plane and the needle moves freely.

## Surveyor's Compass

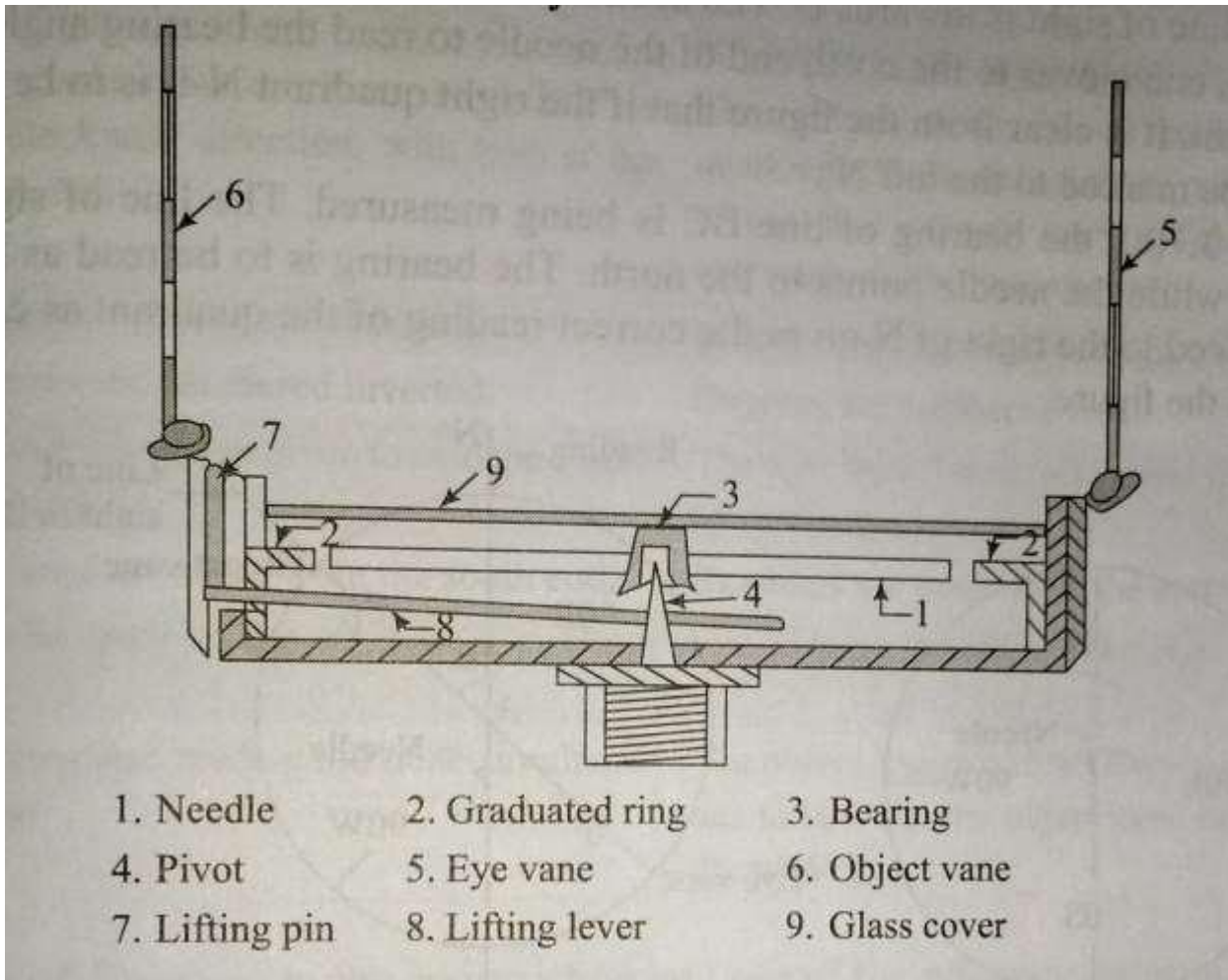

The surveyor's compass is an old type of instrument finding rare use today. A brief description of the instrument is given below. The surveyor's compass has the following components.

### **Magnetic needle:**

The edge bar magnetic needle rests on a pivot of hard metal and floats freely.

### **Graduation ring:**

The graduated ring is not attached to the needle but to the cover box of the compass and inside it. The graduations are in the quadrantal system. The letters N, W, S, and E are marked on the ring along with graduations from  $0^{\circ}$  to  $90^{\circ}$  in each quadrant. The graduations are marked to Half-degrees but can be read to one-fourth of a degree by judgement. The E and W half-degrees but can be read in the ring. The moves with the compass as the box is rotated for sighting, the needle pointing to the north always.

### **Object vane and eye vane:**

The object vane consists of a fine thread or hair fitted onto a metal frame for sighting objects. The eye vane is a similar frame with a fine slit but has no prism to read the graduations.

### **Base and tripod:**

The surveyor's compass cannot be used without a tripod. A base with a ball and socket arrangement and a screwing end for the tripod is used.

An arrangement for lifting the needle off the pivot is provided. This is actuated when the object vane is folded onto the cover glass.

### **Using surveyor's compass:**

The following steps are required.

1. Attach the compass box to the tripod. Place the tripod over the station and centre and level the instrument.
2. Rotate the instrument to bring the object vane in line with the ranging rod at the adjacent station. Looking through the eye vane, finely bisect the ranging rod.
3. Note the reading, by going around to the objective vane side, at the north end of the needle by looking through the glass. Take the reading along with the quadrant by noting down the letters on either side of the reading.

### **Graduation on ring:**

Fig explain the graduations on the ring. N and S are marked along the north-south direction. E and W are marked along the east-west direction but their positions are interchanged, with E marked to the left of N and W to the right of the N. This is done to ensure that the correct quadrant is noted when the reading is taken at the north end of the needle.

Fig , shows the bearing of line AB being measured. The compass is at A and the line of sight is towards B. The needle points to the north direction. After sighting B, one moves to the north end of the needle to read the bearing angle and the quadrant. It is clear from the figure that if the right quadrant N-E is to read, E should be marked to the left N.

In fig the bearing of line BC is being measured. The line of sight is along BC while the needle points to the north. The Bearing is to read as N-W, and W placed to the right of N gives the correct reading quadrants as can be seen from the figure.

## Comparison Between Prismatic and Surveyor's Compasses:

The prismatic compass and the surveyor's compass are both based on the same principle of orientation of a magnetic needle along the north-south direction. Both the instruments measure magnetic bearings.

Differences between the prismatic compass and surveyor's compass

Sl no		Prismatic Compass	Surveyor's Compass
1	Magnetic needle	It has a broad needle but does not act as an index.	It has an edge bar needle and act as an index.
2		The graduated ring is attached with the needle. This does not rotate along with the line of sight.	The graduated ring is fixed to the box and is independent of needle.
3		The graduations are in W.C.B system having zero at the south end. It ranges from $0^{\circ}$ to $360^{\circ}$ in the clockwise direction. The graduations are engraved inverted.	The graduations are in Q.B.system having North and south are marked with $0^{\circ}$ where as east and west are marked with $90^{\circ}$ . It ranges from 0 to 90. East and west are also interchangeable. The graduations are engraved erect.
		The eye vane has a prism to read the graduated ring.	The eye vane has no prism and is not used for reading.
		Can be used in the hand-held position also	Has to be used with a tripod only.
		Sighting and reading are done simultaneously from one position of the observer.	Sighting and reading cannot done simultaneously from one position of the observer

## **Meridians:**

The fixed direction on the surface of the earth with reference to which bearings of survey lines are expressed is called as Meridians .

## **Bearing:**

The horizontal angle between the reference meridian and the survey line measured in a clockwise direction is call bearing.

There are four different types of meridians which can be used as reference directions.

## **True meridian:**

The true or geographic meridian at a point is the line of intersection of a plane passing through the north and south poles and the point with the surface of the earth. Since the earth is approximately a sphere, it is clear that the meridians through different points meet at the north and south poles. The true meridians through different points are not parallel. The true meridian at a place can be established through astronomical observations. The direction of the true meridian remain constant. If the magnetic bearing of the sun is taken at noon, the location of the true meridian at the point can be found. The sun is taken at noon is on a plane passing through the north and south poles at a place. The true bearing of survey line is the horizontal angle that line makes with the true meridian passing through one of its ends.

## **Magnetic meridian:**

The magnetic meridian through a point on the ground is the direction taken by a freely suspended magnetic needle placed at that point. The magnetic meridian can be affected by any serious magnetic interference. Such as an overhead electric cable or the presence of magnetic substance, such be explained later. The magnetic bearing of a survey line is the horizontal angle compass measures the magnetic bearing of a line.

## **Grid Meridian:**

State survey maps are based on one or more true meridians of places so that they placed centrally. Thenorth south lines of the grid are parallel to the line representing the central meridian. The direction of the grid lines along the north-south direction is known as Grid Meridian. The bearing of survey lines referred to and reckoned from grid lines are called Grid Bearing.

## **Arbitrary meridian:**

The arbitrary meridian at a point is any well-defined direction between any two points, such as the spire of a church, a well-defined point on the ground, or a tower. Such meridians can be used for local surveys as they will serve the purpose of a reference direction, and the required computations are possible with such data. The arbitrary bearing of a line is the horizontal angle between the line direction and the direction of the arbitrary meridian through one end of the line.

## **Designation of Bearings:**

The bearing of survey lines are designated in the following systems

1. Whole Circle bearing system (W.C.B)
2. Quadrantal bearing system (Q.B)

### **1. Whole circle bearing system (WCB):**

In this system of bearing of a line measured from the true north or magnetic north in clockwise direction. The value of bearing may vary from 0 to 360. It is also known as Azimuthal System.

### **2. Quadrantal Bearing system (QB):**

In this system of bearing of a line measured eastward or westward from the north or south which ever is nearer. In this system both North and South direction are used as reference meridians. The bearings are measured either clockwise or anticlockwise depending upon the position of the survey line. It is also called Reduced Bearing.

## **Conversion of bearings:**

If the WCBs are given, convert them to quadrantal or reduced bearings. Similarly, QBs can also be converted to WCBs.

### **Whole circle bearing to reduced bearing:**

To convert WCB (measured clockwise from the north direction) to RBs, the following simple rules are followed.

- (a) If the WCB is less than  $90^\circ$ , the RB is numerically equal to the WCB. The quadrant designation is N-E.
- (b) If the WCB is between  $90^\circ$  and  $180^\circ$ , the RB is equal to  $180^\circ - \text{WCB}$ . The quadrant designation is S-E.
- (c) If the WCB is between  $180^\circ$  and  $270^\circ$ , the RB is equal to  $\text{WCB} - 180^\circ$ . The quadrant designation is S-W.
- (d) If the WCB is between  $270^\circ$  and  $360^\circ$ , the equal to  $360^\circ - \text{WCB}$ . The quadrant designation is N-W.



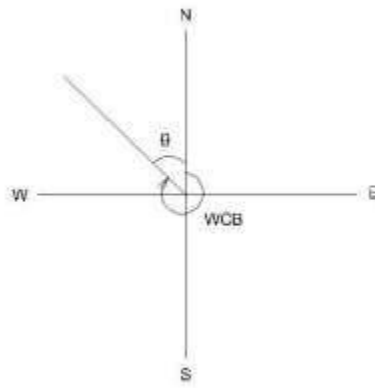
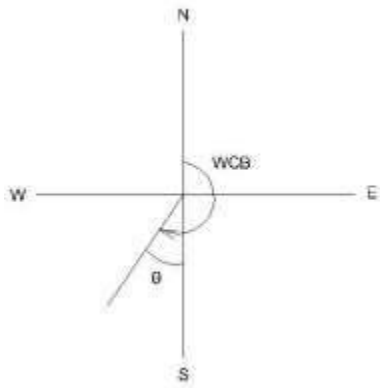
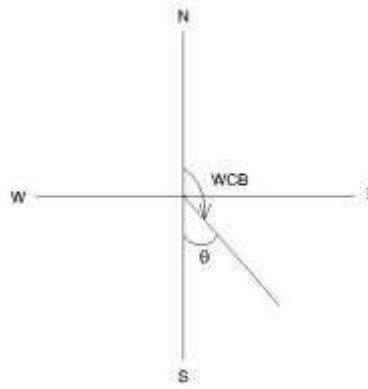
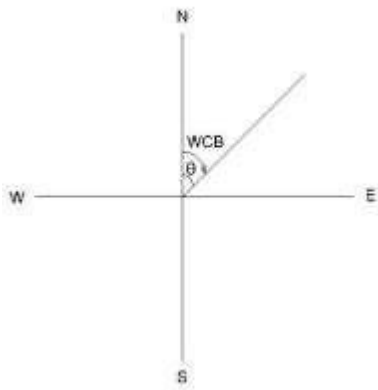

**Quadrantal bearing to whole circle bearing:**

To convert given QBs to WCB, the following simple rules are to be followed.

- (a) If the quadrant designation is N-E, the WCB is numerically equal to the RB.
- (b) If the quadrant designation is S-E, the WCB is equal to  $180^\circ - \text{QB}$ .
- (c) If the quadrant designation is S-W, the WCB is equal to  $180 + \text{QB}$ .
- (d) If the quadrant designation is N-W, the WCB is equal to  $360^\circ - \text{QB}$ .

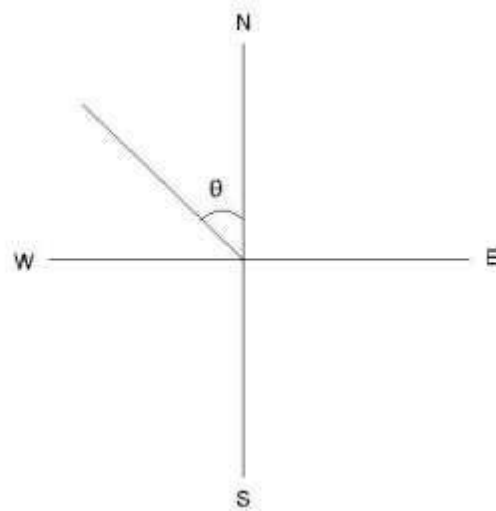
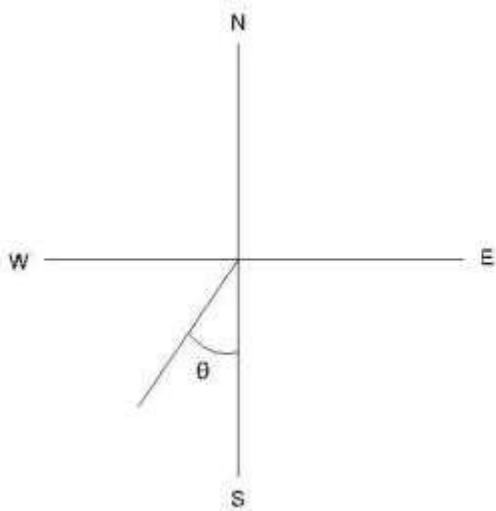
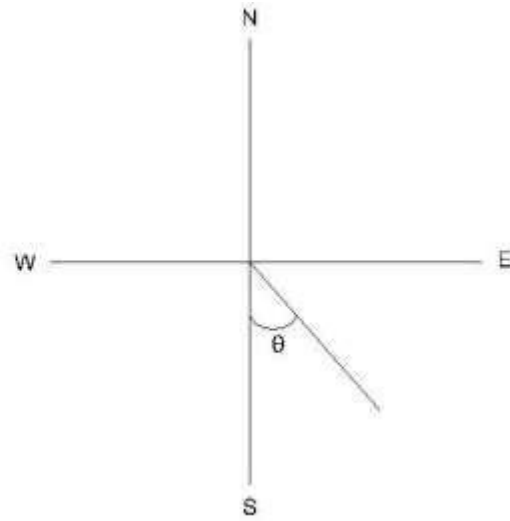
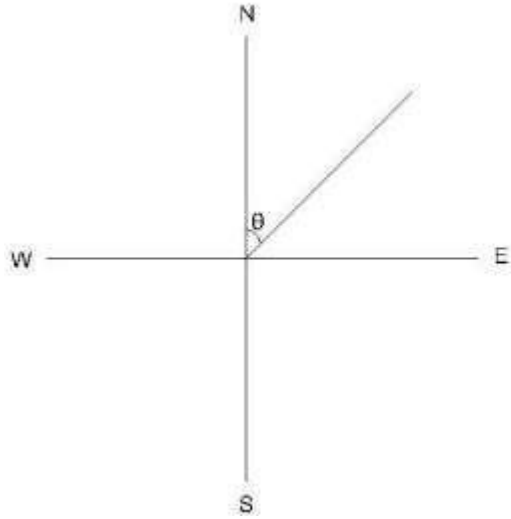

**Example : Convert the following WCBs to RBs and RBs to WCBs.**

- a)  $187^{\circ}30'$ ,  $48^{\circ}15'$ ,  $295^{\circ}0'$ ,  $126^{\circ}30'$
- b)  $N30^{\circ}30'W$ ,  $S45^{\circ}15'E$ ,  $S38^{\circ}15'W$ ,  $N49^{\circ}30'E$ .

Sol.:

- a)
  - $187^{\circ}30'$  This lies in the S-W quadrant.  $RB = 187^{\circ}30' - 180^{\circ} = S7^{\circ}30'W$
  - $48^{\circ}15'$  lies in the N-E quadrant.  $RB = N48^{\circ}15'E$
  - $295^{\circ}00'$ , this lies in the N-W quadrant.  $RB = 360^{\circ} - 295^{\circ} = N65^{\circ}00'W$
  - $126^{\circ}30'$  this lies in the S-E quadrant.  $RB = 180^{\circ} - 126^{\circ}30' = S53^{\circ}30'E$

b)

N30°30'W This lies in the N-W quadrant.  $WCB = 360^{\circ}00' - 30^{\circ}30' = 329^{\circ}30'$   
S45°15'E, This lies in the S-E quadrant.  $WCB = 180^{\circ}00' - 45^{\circ}15' = 134^{\circ}45'$   
S38°15'W, This lies in the S-W quadrant.  $WCB = 180^{\circ}00' + S38^{\circ}15' = 218^{\circ}15'$   
N49°30'E. This lies in the N-E quadrant.  $WCB = 49^{\circ}30'$

## Fore and Back Bearings:

### Fore Bearing :

The bearing of a line in the direction of progress of the survey is called Fore or forward Bearing(FB).

### Back Bearings:

The bearing of a line in the opposite direction of progress of the survey is called Back Bearing(BB).

The relation between the FB& BB is

$$\text{Back Bearing} = \text{Fore Bearing} \pm 180^{\circ}$$

Use + sign if FB is less than  $180^{\circ}$  & Use - sign if FB is greater than  $180^{\circ}$

If the fore bearing is given, in the Quadrantal System, the back bearing is equal to the fore bearing but the designating letters will be exactly opposite. N will be changed to S and vice versa and E will be changed to W and vice versa.

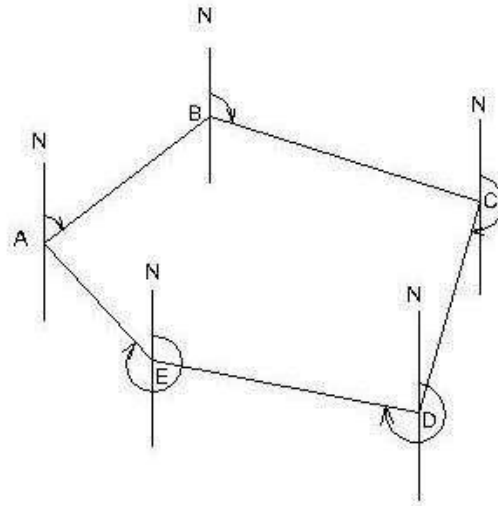
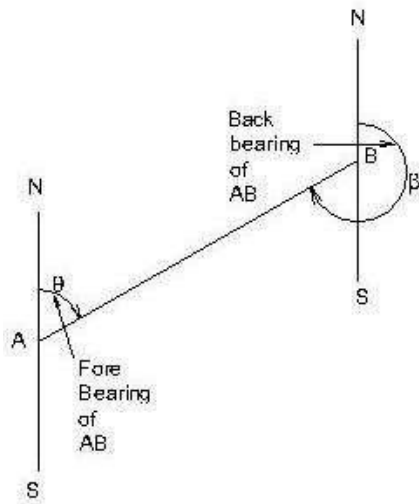

### Calculation of Included Angles from Bearings

At the point where two survey lines meet, two angles are formed – an exterior angle and an interior angle. The interior angle or included angle is generally the smaller angle ( $<180^\circ$ ). The difference of bearing of two adjacent lines is the included angle measured clockwise from the line whose bearing is less.

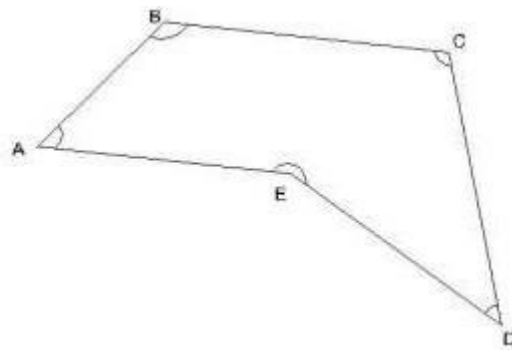
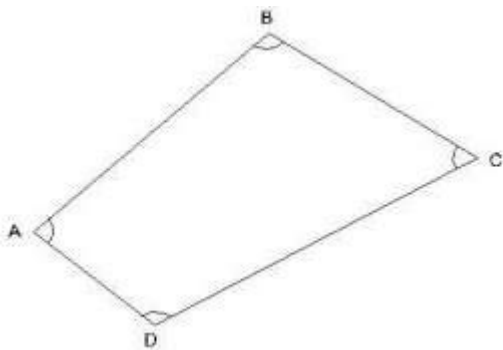

### Calculation of Bearings from Included Angles.

In order to calculate the bearing of the next line the following statement may be made. Add the included angle measured clockwise to the bearing of the previous line. If the sum is :

More than  $180^\circ$ , deduct  $180^\circ$

More than  $540^\circ$ , deduct  $540^\circ$

Less than  $180^\circ$ , add  $180^\circ$ , to get the bearing of the next line.

**Note :**

- In a closed traverse run in anticlockwise direction, the observed included angles are interior angles.
- In a closed traverse run in clockwise direction, the observed included angles are exterior angles.

**Example :** Find the included angle between lines AB and AC, if their reduced bearing are

- |      |                       |                       |
|------|-----------------------|-----------------------|
| i)   | AB N $40^\circ 10'$ E | AC N $89^\circ 45'$ E |
| ii)  | AB N $10^\circ 50'$ E | AC S $40^\circ 40'$ E |
| iii) | AB S $35^\circ 45'$ W | AC N $45^\circ 20'$ E |
| iv)  | AB N $30^\circ 25'$ E | AC N $30^\circ 25'$ W |

Bearings of AB = N  $40^\circ 10'$  E; Bearing of AC = N  $89^\circ 45'$  E  
both lines lie in NE quadrant.

Included angle BAC = difference in the bearings =  $89^\circ 45' - 40^\circ 10' = 49^\circ 35'$ . **Ans.**

(ii)

Bearing of AB = N  $10^\circ 50'$  E; Bearing of AC = S  $40^\circ 40'$  E  
lines lie in adjacent quadrants.

Included angle BAC =  $180^\circ - \text{sum of the bearings} = 180^\circ - (10^\circ 50' + 40^\circ) = 128^\circ 30'$

(iii)

Bearing of AB = S  $35^\circ 45'$  W

Bearing of AC = N  $45^\circ 20'$  E

The lines lie in opposite quadrants,

Included angle CAB =  $180^\circ - (\text{difference in bearings}) = 180^\circ - (45^\circ 20' - 35^\circ 45')$   
 $= 170^\circ 25'$ .

(iv)

Bearing of AB = N  $30^\circ 25'$  E

Bearing of AC = N  $30^\circ 25'$  W

The lines lie in adjacent quadrants.

The Included angle CAB = sum of the bearings =  $30^\circ 25' + 30^\circ 25' = 60^\circ 50'$ .

**Example 2**

The bearings of the sides of a closed traverse ABCDEA are as follow :

Side	F.B.	B.B.
AB	107° 15'	287° 15'
BC	22° 00'	202° 00'
CD	281° 30'	101° 30'
DE	181° 15'	1° 15'
EA	124° 45'	304° 45'

Compute the interior angles of the traverse and exercise necessary checks.,

Solution:

(i) The included angle A = The difference in bearings of AB and AE.

As the bearing of AB is less than of AB, add 360°.

$$\text{Included angle A} = 107^{\circ}15' + 360^{\circ} - 304^{\circ}45' = 162^{\circ}30'$$

The included angle at B = The difference in bearings of BC and BA

$$= 22^{\circ}00' + 360^{\circ} - 287^{\circ}15'$$

$$\text{Included angle B} = 94^{\circ}45'$$

The included angle at C = The difference in bearings of CD and CB

$$= 281^{\circ}30' - 202^{\circ}00' = 79^{\circ}30'$$

$$\text{Included angle C} = 79^{\circ}45'$$

The included angle at D = The difference in bearings of DE and DC

$$= 181^{\circ}15' - 101^{\circ}30' = 79^{\circ}45'$$

$$\text{Included angle D} = 79^{\circ}45'$$

The included angle at E = The difference in bearings of EA and ED

$$= 124^{\circ}45' - 1^{\circ}15' = 123^{\circ}30'$$

. Included angle E = 123° 30'. **Ans.**

**Check :**

Sum of the included angles of a pentagon

$$= (2 \times 5 - 4) = 6 \text{ right angles.}$$

And, sum of the included angles A+B+C+D+E

$$= 162^{\circ}30' + 94^{\circ}45' + 79^{\circ}30' + 79^{\circ}45' + 123^{\circ}30'$$

$$= 540^{\circ}00' \text{ or } 6 \text{ right angles Hence ,O.K.}$$

### Example

A closed compass traverse ABCD was conducted round a lake and the following bearings were obtained. Determine which of the stations are suffering from local attraction and give the values of the corrected bearings:

AB	74° 20'	256° 0'
BC	107° 20'	286° 20'
CD	224° 50'	44° 50'
DA	306° 40'	126° 00'

Solution:

On examination the fore and back bearings of CD differ exactly by  $180^0$ . Hence, stations C and D are free from local attraction. Stations affected by local attraction are A and B.

**Calculation of included angles:**

Interior angle at A = bearing of AD – bearing of AB  
 $= 126^0 00' - 74^0 20' = 51^0 40'$

Exterior angle A =  $360^0 - 51^0 40' = 308^0 20'$

Interior angle at B = bearing of BA – bearing of BC  
 $256^0 0' - 107^0 20' = 148^0 40'$

Exterior angle at B =  $360^0 - 148^0 40' = 211^0 20'$

Interior angle at C = bearing of CB – bearing of CD  
 $= 286^0 20' - 224^0 50' = 61^0 30'$

Exterior angle at C =  $360^0 00' - 261^0 30' = 298^0 30'$

Exterior angle D = bearing of DA – bearing of DC  
 $= 306^0 40' - 44^0 50' = 261^0 50'$

Check : Sum of exterior angles of the quadrilateral ABCD  
 $(2 \times 4 + 4) = 12$  right angles. O.K.

Total sum of exterior angles  
 $= 308^0 20' + 211^0 20' + 298^0 30' + 261^0 50'$   
 $= 180^0 = 12$  right angles. O.K.

**Calculation of bearing :**

Bearing of CD  $224^0 50'$  (given)

Add angle at D =  $+ 261^0 50'$

Sum =  $486^0 40'$

Sum is more than  $180^0$ , subtract  $= (-) 180^0 00'$

Bearing of DA =  $306^0 40'$

Add angle at A =  $+ 308^0 20'$

=  $615^0 00'$

Sum is more than  $540^0$ , subtract  $= (-) 540^0 00'$

Bearing of AB =  $75^0 00'$

Add traverse angle at B +  $211^0 20'$

Sum =  $286^0 20'$

Sum is more than  $180^0$ , subtract -  $180^0 00'$

Bearing of BC =  $106^0 20'$

Add traverse angle at C +  $298^0 30'$

Sum =  $404^0 50'$

Sum is more than  $180^0$ , subtract -  $180^0 00'$

Bearing of CD =  $224^0 50'$  checked

Result: Corrected bearings of the lines are:

Side	FB	BB
AB	$75^{\circ} 00'$	$225^{\circ} 0'$
BC	$106^{\circ} 20'$	$286^{\circ} 20'$
CD	$224^{\circ} 50'$	$44^{\circ} 50'$
DA	$106^{\circ} 40'$	$126^{\circ} 40'$

### Effect of earth's magnetism:

The earth behaves like a strong magnet with its poles placed away from the geographic north and south poles. One pole of the earth's magnet is placed at approximately  $70^{\circ}$  north latitude and  $96^{\circ}$  west longitude in Canada and similar pole exists at a diametrically opposite location in the Southern hemisphere. A magnetic needle supported in such a way that it can rotate in a vertical plane will take up a vertical position at such a place. Since one end of a magnetic needle points to the north direction and is designed as the north pole of the needle, it is clear that the imaginary magnet inside the earth has its south pole there. This is because unlike poles attract each other. The north pole of a magnet is strictly the north-seeking pole.

The magnetic lines or forces due to earth's magnetism generally go from near the South pole to North pole. Such lines of force are parallel to the surface (horizontally) only near the equator. At other places, as these lines to the poles, they are direction as the lines of forces; it will dip (from the horizontal) by a small angle. This is known as the dip angle. The dip angle increases as we go from the equator to the poles.

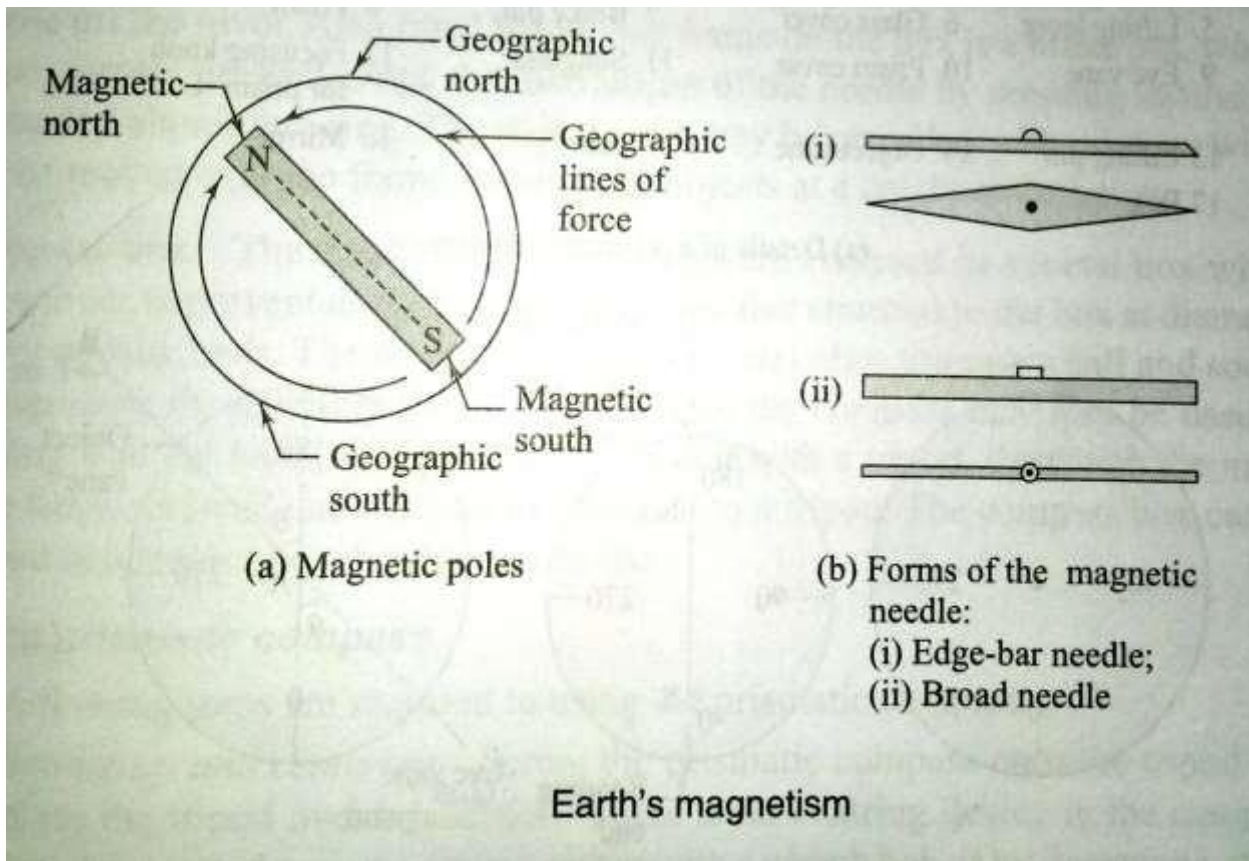



A magnet needle is generally made perfectly symmetrical and supported on a hard, pointed pivot. To make it take up a horizontal position, it is generally weighted with an adjustable weight. As the north pole or the north-seeking pole of the needle dips down in the Northern hemisphere, the needle is weighted in the southern segment of the needle there. Similarly, the northern segment of the needle is weighted in the Southern hemisphere. Shown in the plan and section of two forms of magnetic needles commonly used—one with pointed ends (edge-bar needle) and other of uniform width (broad form needle). The north pole, or the north-seeking pole, of a magnetic needle when freely suspended gives us the direction of the magnetic lines of the forces and this is used as a reference in compass surveying.

### **Magnetic Declination:**

- The horizontal angle between true north and magnetic north at a place at the time of observation, is called magnetic declination.
- The angle of convergence between the true north and magnetic north at any place does not remain constant.
- It depends upon the direction of the magnetic meridian at the time of observation.
- If the magnetic meridian is on eastern side of true meridian, the angle of declination is said to be eastern declination or positive declination.
- On the other hand if the magnetic meridian is on western side, the declination is said to be western declination or negative declination is zero.
- The imaginary lines joining the places of equal declination either positive or negative, on the surface of the earth, are called “Isogonic lines”.
- The isogonic lines having zero declination are known as ‘Agonic lines’.

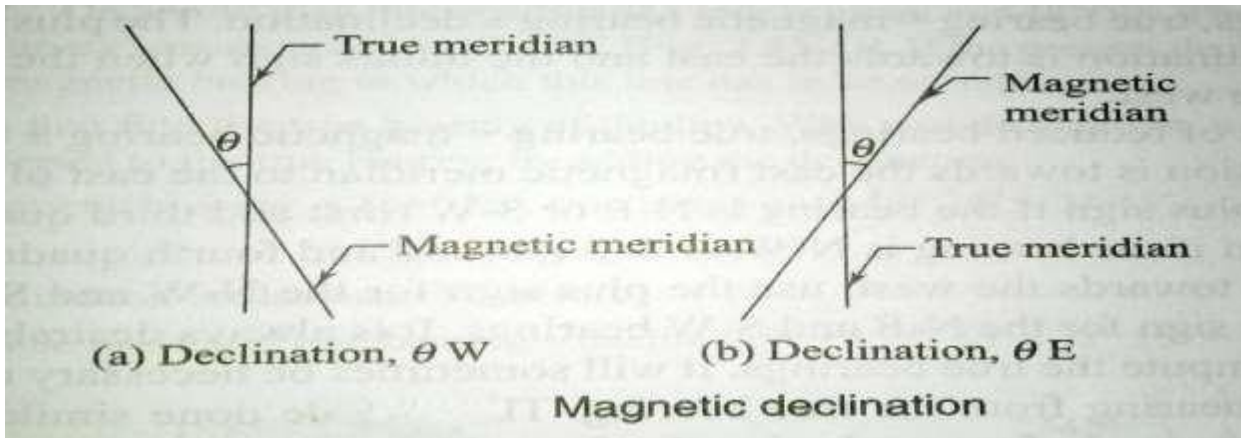

Mariners generally call magnetic declination as ‘variation’.

### 1. Determination of Magnetic Declination:

- True meridians at a number of places in the area, are determined by making astronomical observations (specially to stars).
- Compass observations are made by sighting the true meridians at the places
- The angle of inclination between true meridian and magnetic meridian given by a compass reading, is the desired magnetic declination at the place.
- Magnetic declination = True bearing –Magnetic bearing”.\*

### 2. Calculation of True Bearing.

True Bearing = Magnetic bearing  $\pm$  magnetic declination,

use + ve sign if declination is east

and –ve sign, if it is west.

### 3. Calculation of Magnetic Bearing.

Magnetic bearing = True Bearing  $\pm$  magnetic declination,

use –ve sign for eastern declination and + ve sign for western declination.

## Variation of Declination

Declination at any place does not remain constant but keeps on changing from time to time. These variations may be classified under four heads *viz.*

1. Secular variation
2. Annual variation
3. Diurnal variation
4. Irregular variation

**1. Secular Variation.** The earth magnetic poles are continually changing their positions relatively to the geographical poles. Earth Magnetic meridian also changes and affects the declination of places. Secular variation is a slow continuous change and declination of places. Alters in a more or less regular manner from year to year. Due to its magnitude, secular variation is the most important for land surveyors. It appears to be of periodic character and follows a sine curve. The swing of declination at a place over a period of centuries, may be compared to a simple harmonic motion. A secular change from year to year is also not uniform for any given place. It is also different for different places. To convert magnetic bearings into true bearings, an accurate amount of declination is essentially required. As such it is very important for a surveyor to know the exact amount of declination. When observations for the declination are made in different years of a century, it is revealed that magnetic meridian moves from one side of true meridian to the other. The change produced annually by secular variation at different places amounts from 0.02 minute to 12 minute. The variation at depends upon the geographical position of different place. The annual secular change is greatest near the middle point of a complete cycle and least at its extreme limits.

**2. Annual Variation.** Change in declination at a place over a period of one year, is known as annual variation. From the observations made at different places over a period of 12 months, it is found that annual variation is about 1 minute to 2 minutes, depending upon their geographical positions.

**3. Diurnal Variation.** The departure of declination from its mean value during a period of 24 hours at any place is called diurnal variation. The diurnal variation depends upon the following factors:

- (1) **The geographical position of the place.** It is greatest for the places in higher latitudes and lesser near the equator.
- (2) **Season of the year.** It is comparatively more in summer than in winter at the same place.
- (3) **The time.** It is more in day and less at night.
- (4) **The year of the cycle.** It is different for different years in the complete cycle of secular variation.

**(4) Irregular Variation.** Abrupt change of declinations at places due to magnetic storms, earthquakes and other solar influences, are called irregular variations. These disturbances may occur at any time at any place and cannot be predicted. The displacement of a needle may vary in extent from  $1^{\circ}$  to  $2^{\circ}$ .

**Example.** The true and magnetic bearings of a line are  $78^{\circ} 45'$  and  $75^{\circ} 30'$  respectively. Calculate the magnetic declination at the place.

**Solution.**

$$\begin{aligned}\text{Magnetic declination} &= \text{True bearing} - \text{Magnetic bearing} \\ &= 78^{\circ} 45' - 75^{\circ} 30' \\ &= 3^{\circ} 15'\end{aligned}$$

As the sign is + ve, declination is east of true meridian.

. Magnetic declination =  $3^{\circ} 15'$  East.

## **Error in compass surveying:**

The following errors are common in surveying with compass.

### **Instrumental errors:**

It is caused by the defective parts of the instrument. These are

- (a) The needle may not be straight, giving wrong readings.
- (b) The pivot point may have become blunt and the needle may not move freely.
- (c) The line of sight may not pass through the centre of the graduated ring.
- (d) The ring may not move in a horizontal plane due to the dip of the needle as a result of the wrong adjustment of the balancing weight.
- (e) The cross hair in the objective vane may not be straight or may have become loose.

### **Personal errors:**

- (a) Reading the graduations in the wrong direction or reading the quadrants wrongly.
- (b) Improper centering of the compass over the station.
- (c) Not leveling the compass properly.
- (d) Not bisecting the signal at a station properly.

## **Other errors:**

- (a) Variation in declination during the day, when the survey is carried out over a long duration during the day
- (b) Local attraction due to the proximity of external magnetic influences at one or more stations
- (c) Other variations due to magnetic storms, cloud cover, etc, which affect the magnetic needle.

## **PRECAUTIONS TO BE TAKEN IN COMPASS SURVEY**

The instrumental and observational errors during a compass survey may be minimized by taking the following precautions:

- Set up and level the compass carefully.
- Stop the vibrations of the needle by gently pressing the brake-pin so that it may come to rest soon.
- Always look along the needle and not across it, to avoid parallax.
- When the instrument is not in use, its magnetic needle should be kept off the pivot. If it is not done, the pivot is subjected to unnecessary wear which may cause sluggishness of the magnetic needle.
- Before taking a reading, the compass box should be gently tapped to ensure that the magnetic needle is freely swinging and has not come to rest due to friction of the pivot.
- Stations should be selected such that these are away from the sources of local attraction.
- Surveyor should never carry iron articles, such as a bunch of keys which may cause local attraction.
- Fore and back bearings of each line should be taken to guard against the local attraction. If the compass is not set at the end of a line, the bearings may be taken from any intermediate point along that line.
- Two sets of readings should be taken at each station for important details by displacing the magnetic needle after taking one reading.
- Avoid taking a reading in wrong direction viz.  $25^\circ$  to  $20^\circ$  instead  $20^\circ$  to  $25^\circ$  and so.
- If the glass cover has been dusted with a handkerchief, the glass gets charged with electrostatic current and the needle adheres to the glass cover. This may be obviated by applying a moist finger to the glass.
- Object vane and eye vane must be straightened before making observations.

## **MAINTENANCE OF PRISMATIC COMPAS:**

The Prismatic compass is a fine instrument that is easy to set up and use. It is ideally suited for rough, speedy survey work. The following points are important for maintaining the compass in good condition. The compass comes in a leather cover. The compass should be kept in its cover when not in use.

- The compass should be tested frequently, before using it for surveying. Check regularly to see whether the magnetic needle is freely moving or sluggish.
- Set up the compass at a point and take the bearing of a line connecting to a well-defined object. Rotate the compass and immediately bring it back to the same point, bisect and take the reading. The reading should be the same. If not, the needle is not moving properly due to a blunt pivot.
- Check whether the needle (or the graduated ring) moves in a horizontal plane
- Keep the instrument free of dust and clean the glass cover with a fine cloth.

## **COMPASS SURVEYING**

### **Principle of traversing**

A series of connected straight line each joining two points on the ground is called a traverse. End points are known as traverse stations and straight lines between two consecutive stations are called traverse legs.

Traverse may be either a closed traverse or an open traverse.

### **Closed Traverse:**

A traverse which either originates from a station and closes on same station or runs between two stations whose coordinates are known in terms of a common system of coordinates is known as closed traverse. In closed traverse accuracy of linear as well as angular measurements may be known.

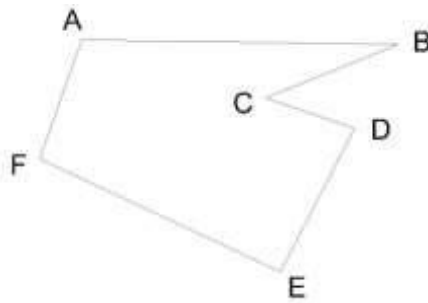

Closed Traverse

## **Open Traverse:**

A traverse which neither returns to its starting station nor ends on another known station is known as open traverse. In open traverse accuracy of linear as well as angular measurement may not be checked.

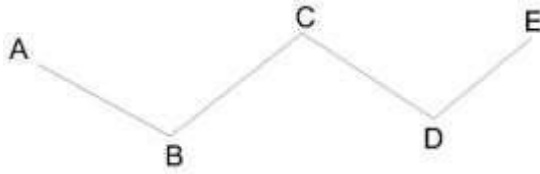

Open Traverse

### **Difference between Chain survey And Compass Survey**

Chain survey is preferred to if the area to be surveyed is small in extent and higher accuracy is aimed at where as if the area is comparatively large with undulation and less accuracy is required, compass survey is adopted.

## **6.3 Local Attraction:**

North end of a freely suspended magnetic needle always points to the magnetic north, if not influenced by any other external forces except the earth's magnetic field.

The magnetic needle gets deflected from its normal position, if placed near magnetic rocks, iron ores cables etc. such a disturbing force is known as local attraction.

### **Detection of local attraction:**

The presence of local attraction at any station may be detected by observing the fore and back bearings of the line. If the difference between fore and back bearing is  $180^\circ$ , both end stations are free from local attraction. If not, the discrepancy may be due to:

- (1) An error in observation of either fore or back bearings or both.
- (2) Presence of local attraction at either station.
- (3) Presence of local attraction at both the stations.

The correction to other stations may be made according to the following methods.

- i) By calculating the included angles at the affected stations
- ii) By calculating the local attraction of each station and then applying the required corrections starting from the unaffected bearing.

### Method of elimination of local attraction by in closed :

- i) Compute the included angles at each station from the observed bearing, in case of a closed traverse.
- ii) Starting from the unaffected line run down the correct bearing of the successive sides.

### Method of elimination of local attraction by applying corrections to bearing in closed :

Following steps are followed

- i) Calculate the magnitude and direction of the error due to local attraction at each affected station
- ii) Run down bearing starting from the bearing unaffected by local attraction.

## 6.4 Methods of Plotting of Traverse:

Before plotting of traverse survey it should be checked whether the observed bearing are correct. If not the required correction to each bearing may be made so that the traverse will perfect in the geometrical figure based on field data.

The traverse may be plotted by one of the method

**1.By Parallel Meridians;** After deciding the layout of the traverse a line representing the magnetic meridian through the location of the station is drawn on the paper .The bearing of the line AB is plotted with the ordinary protractor and its length duly reduced to scale, is marked off to get the location of station A is drawn . The bearing of BC is plotted and length BC is plotted to scale .The process is continued till last station is plotted. In a close traverse last line should be end on the starting station A. In case of a closed circuit or at any other known station in case of linear closed traverse.If dose not the distance between two locations of the same station is termed as closing error.

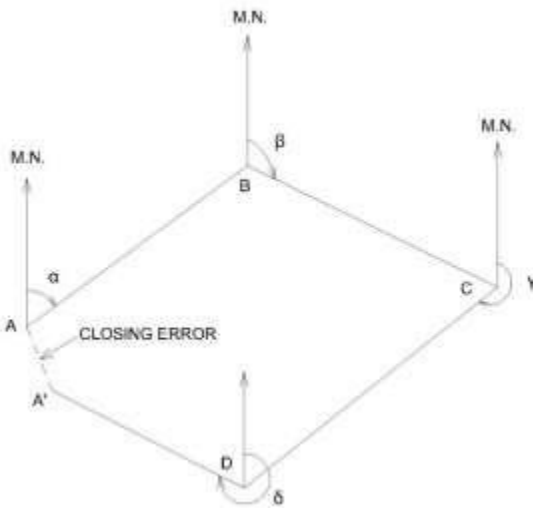



## 2. By Included Angles;

After deciding the location of the station A on the paper draw a line to represent the magnetic meridian passing through A . Plot the magnetic bearing of the chain line AB and plot AB duly reduced to scale. Now plot the included angle ABC by a protractor and plot the location of station C .The process is continued till all the station are plotted. It may be noted that for a closed traverse if linear measurement between stations are correct and plotting is error less the closing station will coincide with the station A .If not the distance between two location of the starting station is known as closing error.

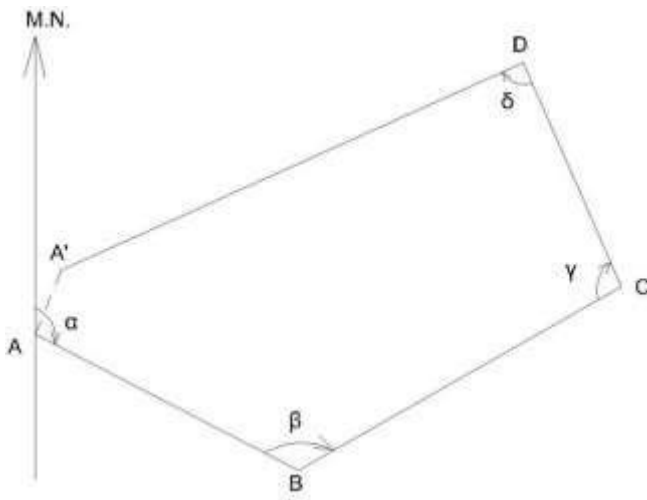

## 3. Plotting By tangents.

Deflection angles of the chain lines are plotted by geometry construction with the help of their natural tangents. The traverse may be plotted as followed.

From the location of the starting station A draw a line passing through A to represent its magnetic meridian .To draw the bearing of traverse leg AB cut a length of 10 cm on the magnetic meridians of station A at B<sub>1</sub>. At B<sub>1</sub> erect a perpendicular B<sub>1</sub>B<sub>2</sub> on the proper side of the meridian .Take B<sub>1</sub>B<sub>2</sub>equal to 10x tangent of the reduced bearing i,e angle of deflection of the line AB in centimeter.

Join AB<sub>2</sub> and produce it to get the direction of traverse line AB plot length of AB on the lineAB<sub>2</sub> to a desired scale.

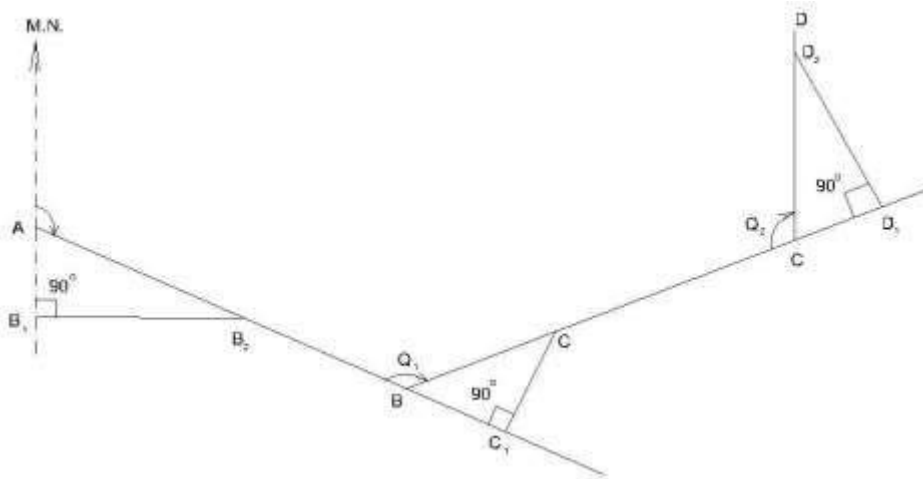

The Deflection angles of the successive chain lines for the purpose of plotting are obtained by the following formulae.

1.If the included angle between adjacent lines is between 0° and 90°, deflection angle is equal to the included angle.

2. If the included angle is between 90° and 180°, subtract the given included angle from 180° to get the deflection angle.

3. If the included angle is between 180° and 270°, subtract 180° from the given included angle.

4. If the included angle is between 270° and 360°, subtract the given included angle from 360° to get the deflection angle.

Continue the process till all the traverse legs are plotted.

### Adjustment of Closing Error:

When a closed traverse is plotted from the field measurements, the end station of a traverse generally does not coincide exactly with its starting station. This discrepancy is due to the errors in the field observations i.e. magnetic bearings and linear distances. Such an error of the traverse is known as **closing error or error of closure**.

When the angular and linear measurements are of equal precision, graphical adjustment of the traverse may be made. This method is based on the Bowditch's rule. Corrections are applied to lengths as well as to bearings of the lines in proportion to their lengths. Graphical method is also sometimes known as proportionate method of adjustment.

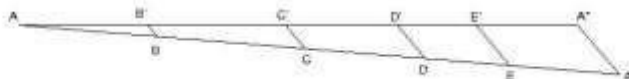
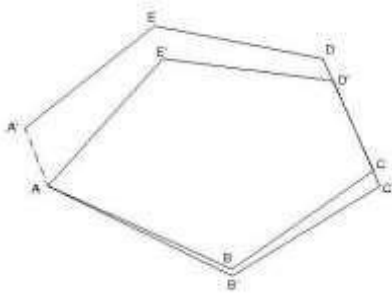

**Method.** The adjustment of a compass traverse graphically, may be made as follow:

Let ABCDEA' be a closed traverse as plotted from the observed magnetic bearings and linear measurements of the traverse legs. A is the starting station and A' is the location of the station A as plotted. Hence, A'A is the closing error.

**Adjustment.** Following procedure may be adopt.

- 1 Draw a straight line AA' equal to the perimeter of the traverse to any suitable scale.
- Set off the distances AB, BC, CD, DE, and EA' equal to the lengths of the sides of the traverse.

- Draw A'A'' parallel and equal to the closing error A'A.
- Draw parallel lines through points B,C,D, and E to meet AA'' at B',C'D' and E'.
- Draw parallel lines through the plotted stations B,C,D,E and plot the errors equal to BB',CC',DD' in the direction of A'A'.
- Join the points AB'C'D'E' A to get the adjusted traverse.

## **Error in chain and compass surveying:**

### **Errors in Chaining:-**

1. Incorrect length of chain
2. Incorrect ranging
3. Loose Chain
4. Temperature change
5. Variation in pull
6. Errors in slope measurement
7. Incorrect marking
8. Personal mistake

The following errors are common in surveying with compass.

### **Instrumental errors:**

It is caused by the defective parts of the instrument. These are

- (a) The needle may not be straight, giving wrong readings.
- (b) The pivot point may have become blunt and the needle may not move freely.
- (c) The line of sight may not pass through the centre of the graduated ring.
- (d) The ring may not move in a horizontal plane due to the dip of the needle as a result of the wrong adjustment of the balancing weight.
- (e) The cross hair in the objective vane may not be straight or may have become loose.

### **Personal errors:**

- (a) Reading the graduations in the wrong direction or reading the quadrants wrongly.
- (b) Improper centering of the compass over the station.
- (c) Not leveling the compass properly.
- (d) Not bisecting the signal at a station properly.

### **Other errors:**

- (d) Variation in declination during the day, when the survey is carried out over a long duration during the day
- (e) Local attraction due to the proximity of external magnetic influences at one or more stations
- (f) Other variations due to magnetic storms, cloud cover, etc, which affect the magnetic needle.

### **PRECAUTIONS TO BE TAKEN IN COMPASS SURVEY**

The instrumental and observational errors during a compass survey, may be minimized by taking the following precautions:

- Set up and level the compass carefully.
- Stop the vibrations of the needle by gently pressing the brake-pin so that it may come to rest soon.
- Always look along the needle and not across it, to avoid parallax.
- When the instrument is not in use, its magnetic needle should be kept off the pivot. If it is not done, the pivot is subjected to unnecessary wear which may cause sluggishness of the magnetic needle.
- Before taking a reading, the compass box should be gently tapped to ensure that the magnetic needle is freely swinging and has not come to rest due to friction of the pivot.
- Stations should be selected such that these are away from the sources of local attraction.
- Surveyor should never carry iron articles, such as a bunch of keys which may cause local attraction.
- Fore and back bearings of each line should be taken to guard against the local attraction. If the compass is not set at the end of a line, the bearings may be taken from any intermediate point along that line.
- Two sets of readings should be taken at each station for important details by displacing the magnetic needle after taking one reading.
- Avoid taking a reading in wrong direction viz.  $25^\circ$  to  $20^\circ$  instead  $20^\circ$  to  $25^\circ$  and so.
- If the glass cover has been dusted with a handkerchief, the glass gets charged with electrostatic current and the needle adheres to the glass cover. This may be obviated by applying a moist finger to the glass.
- Object vane and eye vane must be straightened before making observations.

## CHAPTER – 4

### MAP READING CADASTRAL MAPS & NOMENCLATURE

The cadastre of a country is its **register of property titles** and is usually managed by government agencies – in Australia these are often called Land Titles Offices. The information recorded includes an accurate description of the location of a parcel of land and who owns it. It may also record what the land can be used for (e.g. residential or not, national park etc) and may also show the location and shape of buildings. In some countries it also records the **value of a property**. In these cases the cadastre may also be used for land taxation purposes.

This plan MUST NOT BE FOLDED but may be rolled.

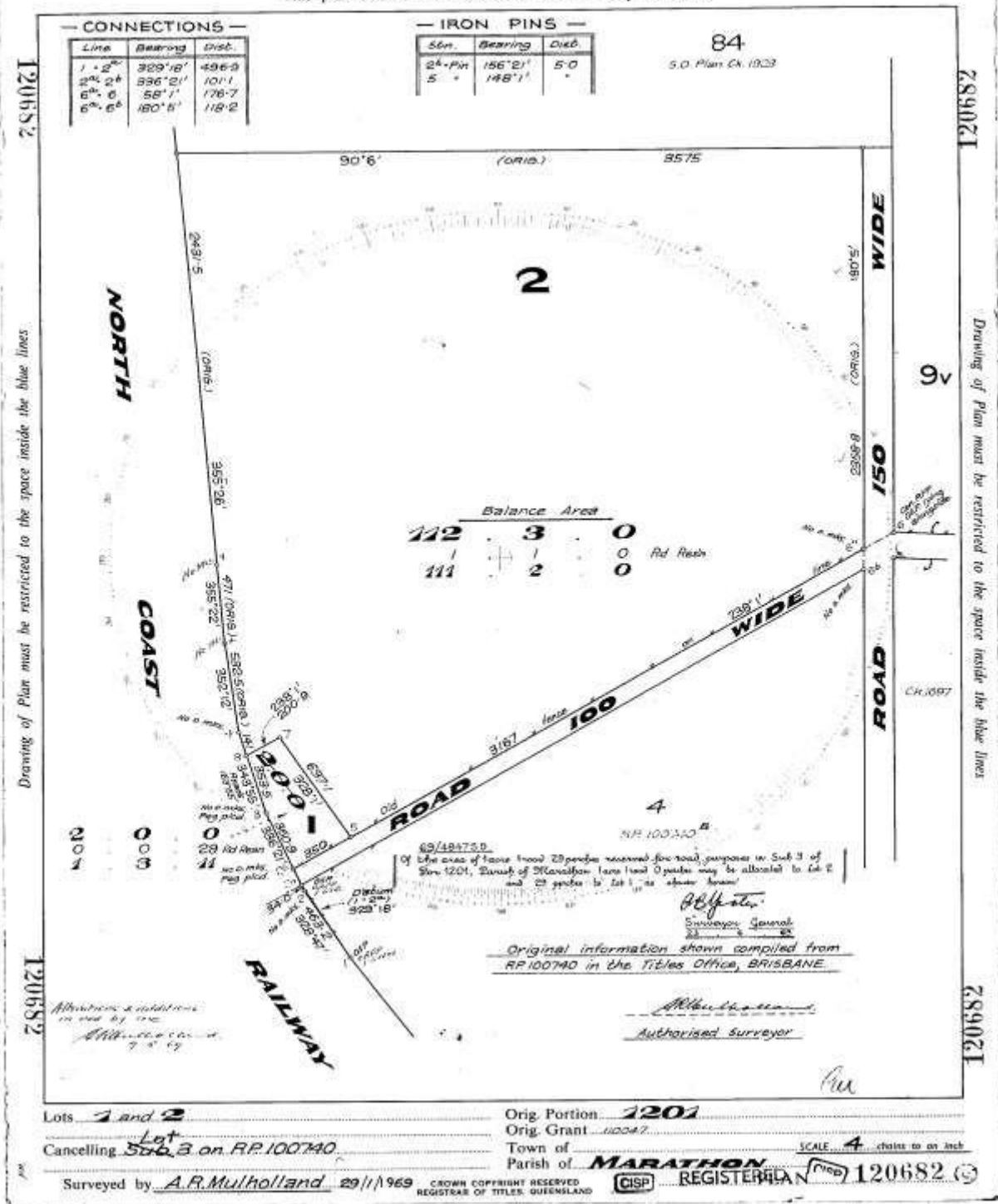

>This is an excellent example of a cadastral plan. Note the detailed information relating to points along the boundary of both parcels of land and two of the adjoining roads.

Because 2 parcels of land are shown on the one plan it is most likely that this cadastral plan was drawn when the parcel of land was sub-divided into 2 parcels.

>The foundation block of a cadastre is the cadastral plan (or survey plan). This is produced by a registered/licensed surveyor who accurately measures and records the boundaries of each property. This occurs whenever a new land parcel is created and each new survey produces a new survey plan. Because of this each plan is static in time, i.e. it represents the shape and status of the cadastre at the time of survey.

>Cadastral plans from different parts of the world, or indeed different parts of Australia, will contain different information – this is dependent on local legislation relating to the registering of cadastral plans into the local cadastre. A properly registered cadastral plan is a legal document.

### ***How is a Cadastral Map different to a Cadastral Plan?***

Cadastral maps are produced by joining together individual cadastral plans. A cadastral map is a general land administrative tool which has no real legislative basis (as a cadastral plan does). It is often created on demand and therefore not necessarily up-to-date. These maps are used by a broad range of people (public and professional) for all manner of things including real estate sales, valuation, Land Title Office management of the cadastre, planning etc.

Cadastral mapping is one of the best known forms of mapping, because it is the mapping that shows all of the land parcels in relation to one another and to the adjoining roads. It is also one of the most ancient forms of mapping – for example ancient Egyptians are known to have developed cadastral records so that land ownership could be re-established after the annual flooding of the Nile River.



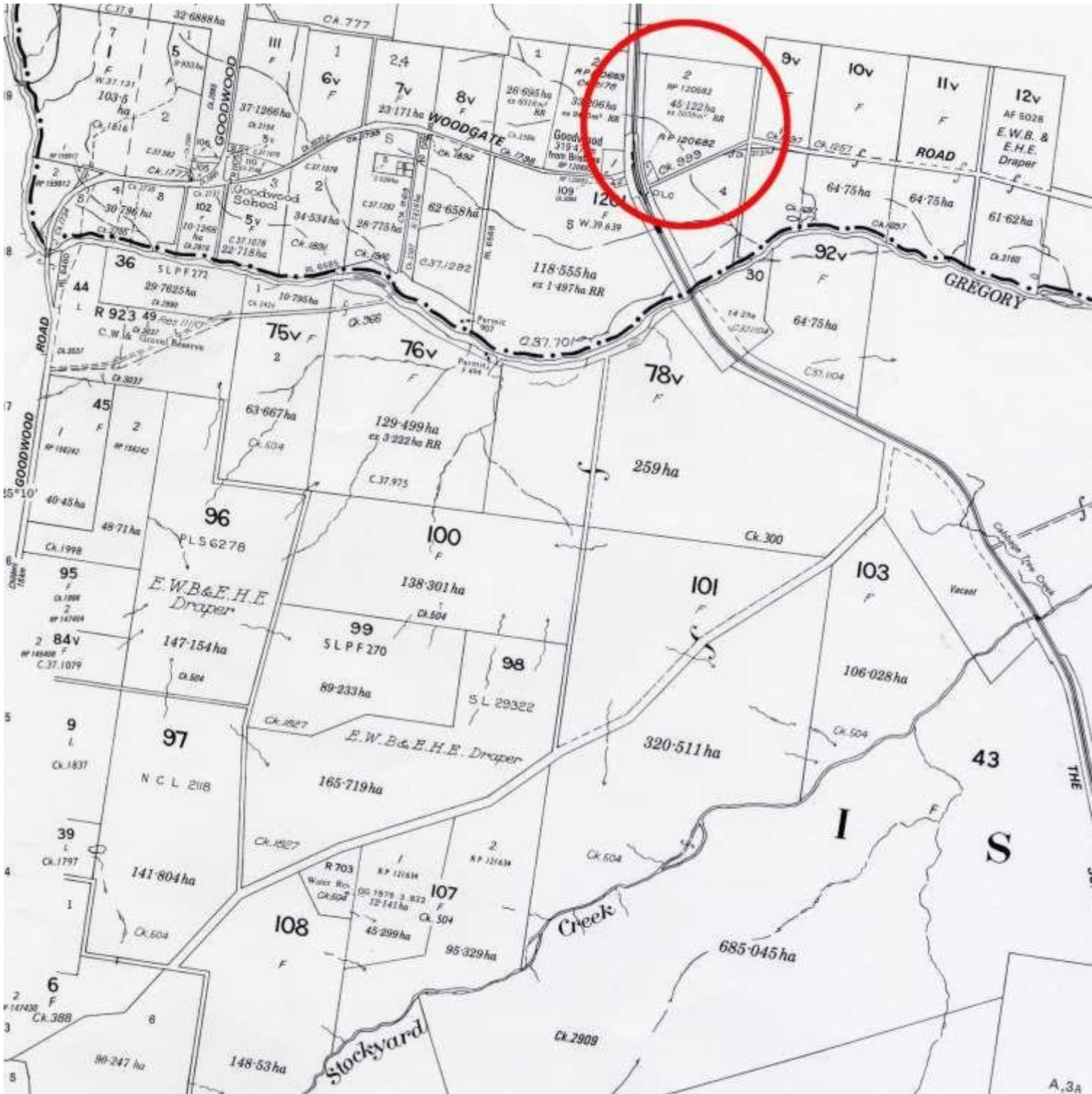

This is an example of a cadastral map and the area circled in red shows the cadastral plan which is described above.

*These maps are made from numerous cadastral plans. Please note that the information shown is different to the plan. In particular, information which allows the precise dimensions of the parcel of land is no longer shown, rather individual parcels of land are identified by their relationship to each other. Some (but not all) parcels of land have additional information shown – for example how big it is (in hectares), who owns it or what it is used for (eg Gravel Reserve, Water Reserve).*

*There is minimal base information supplied – mainly road and railway reserves and watercourses.*

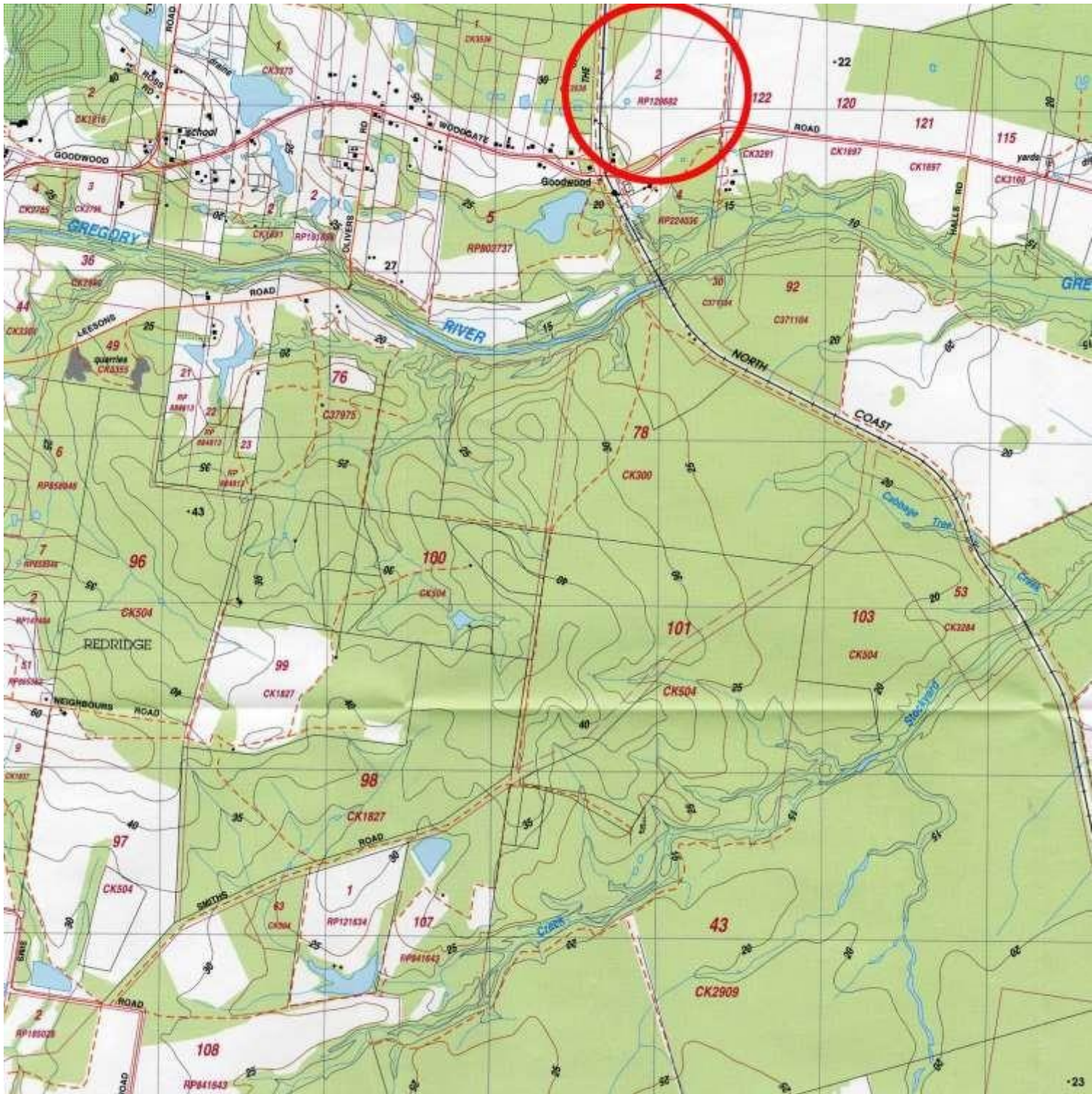

This map is over the same area as the cadastral plan above. In this case the cadastral information has been further generalised and overlaid on a [topographic map](#). The primary purpose of this map is to provide better base information to compare against the cadastral information.

## **CHAPTER – 5**

# **PLANE TABLE SURVEYING**

### **Definition:-**

A **plane table** is a device used in [surveying](#) and related disciplines to provide a solid and level surface on which to make field drawings, charts and maps. The early use of the name *plain table* reflected its simplicity and plainness rather than its flatness.

### **Objectives:-**

- It is suitable for location of details as well as contouring for large scale maps directly in the field.
- As surveying and plotting are done simultaneously in the field, chances of getting omission of any detail get less.
- The plotting details can immediately get compared with the actual objects present in the field. Thus errors as well as accuracy of the plot can be ascertained as the work progresses in the field.
- Contours and specific features can be represented and checked conveniently as the whole area is in view at the time of plotting.
- Only relevant details are located because the map is drawn as the survey progresses. Irrelevant details get omitted in the field itself.
- The plane table survey is generally more rapid and less costly than most other types of survey.
- As the instruments used are simple, not much skill for operation of instruments is required. This method of survey requires no field book.

### **Disadvantage:-**

- The plane table survey is not possible in unfavorable climates such as rain, fog etc.
- This method of survey is not very accurate and thus unsuitable for large scale or precise work.
- As no field book is maintained, plotting at different scale require full exercise.
- The method requires large amount of time to be spent in the field.
- Quality of the final map depends largely on the drafting capability of the surveyor.
- This method is effective in relatively open country where stations can be sighted easily

### **Principle :-**

The principle of plane table survey is **Parallelism** ,It means that the ray drawn from station to objects on the paper are parallel to the lines from the station to the objects on the ground.

### **Accessories of plane table:-**

- a. Plane table
- b. Alidade
- c. The Spirit level
- d. The compass
- e. The U – Fork or plumbing Fork with plum bob

**a. The Plane Table:-**

- i. The plane table is a drawing board of size 750mm X 600mm made of well seasoned wood like Teak, pine, etc.
- ii. The topsurface of the table is well leveled .
- iii. The bottom surface consists of a threaded circular plate for fixing the table with the tripod stand by a wing nut.
- iv. The plane table is meant for fixing the a drawing sheet over it.
- v. The position of the objects are located on this sheet by drawing rays and plotting to any suitable scale.



**b. Alidade:-**

There are two types of alidade –Plain and telescopic alidade.

1. Plain alidade:-the plain alidade consists of a metal or wooden ruler of length about 50cm. one of its edge is beveled, and is known as fiducial edge. It consists of two vanes at both ends which are hinged with the ruler. One is known as object vane and the other is known as sight vane.

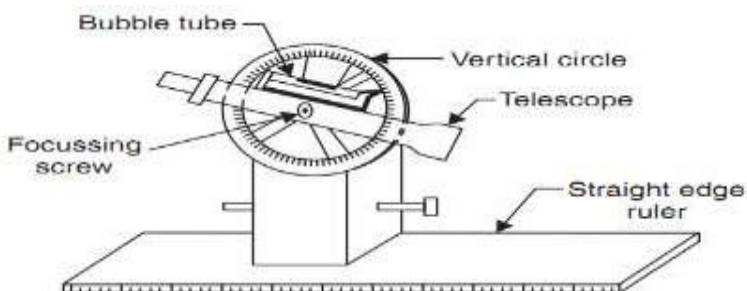
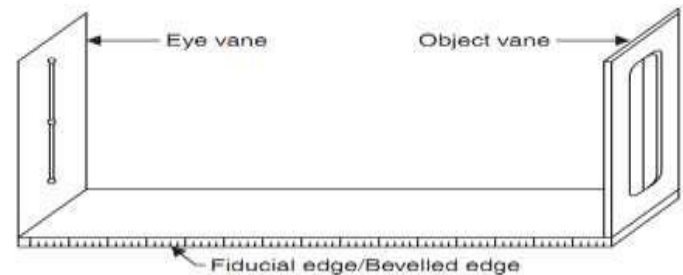

2. Telescopic alidade:-The telescopic alidade consists of a telescope meant for inclined sight or sighting distant objects clearly. The alidade has no vanes at the ends, but is provided with the fiducial edge

The function of the alidade is to sight objects. The rays should be drawn along the fiducial edge.

c. **The Spirit level:** - It is a smaller metal tube containing a small bubble of spirit. The bubble is visible on the top along a graduated glass tube. The spirit level is meant for leveling the plane table.



d. **The compass:**-There are two kinds of compass

i. The trough compass

ii. The circular box compass.

i. **The trough compass:**-It is rectangular box made of non magnetic metal containing a magnetic needle pivoted at the centre. This compass consists of '0' mark at both the ends to locate N-S direction.

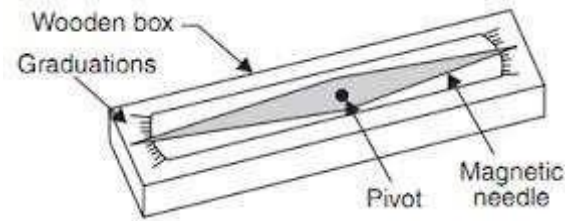

ii. **The Circular box compass:**-It carries a pivoted magnetic needle at the centre. The circular box is fitted on square base plate. Sometimes two bubble tubes are fixed at the right angles to each other on the base plate. The compass is meant for making the north direction of the map.

e. **The U – Fork or plumbing Fork with plumb bob:**-The U- fork is a metal strip bent in the shape of a 'U' (Hair pin) having equal arm lengths. The top arm is pointed and the bottom arm carries a hook for suspending a plumb bob .

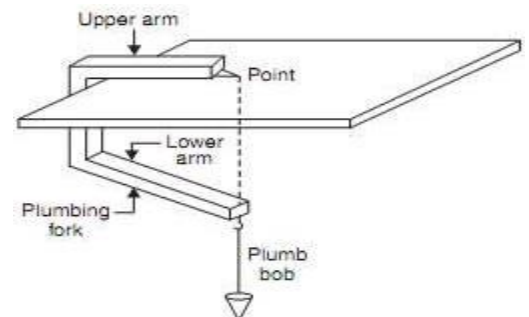

This is meant for centering the table over a station.

## **Procedure of setting up plane table over a station**

The following five steps should be followed while setting up a plane table over a station:-

1. **Fixing the table on the tripod stand:-**The tripod stand is placed over the required station with its leg well apart. Then the table is fixed on it by a wing nut at the bottom.
2. **Leveling the Table:-**The Table is leveled by placing the spirit level at a different corners and various position of the table. The bubble is brought to the centre of its run at every position of the table by adjusting he legs.
3. **Centring the table:-**At first the Drawing sheet is fixed on the table. A suitable point is selected on the sheet to represent the station “A” on the ground.

A pin is then placed on this selected point.

The upper end of the U-Fork is made in contact with the station pin and the plumb bob is suspended from the hook at the lower end is brought over the station “A” by turning the table clock wise or anti clock wise or slightly adjusting the table or legs.

This operation is called Centering and the table is clamped. Care should be taken that this operation should be done without disturbing the Leveling

4. **Marking the North line:-**The trough compass is placed on the right hand top corner of the drawing sheet with its north end approximately towards the north. Then the compass is turned clock wise or anti clock wise so that the needle exactly coincides with the 0-0 mark . Now a line representing the north line is drawn through the edge of the compass. It should be ensured table is not turned.

5. **Orientation:-** When the plane table is survey is to be conducted by connecting several station , the orientation must be performed at successive station . it may be done by two methods

a. Backsighting method    b. magnetic needle method.

### **a. Back sighting Method:-**

This method is accurate and is always preferred. The following steps are followed during the back sighting method .

- i. Suppose A and B are two station . The plane table set up over A. The table is leveled by the spirit level and centered by the U- Fork so that the point a is just over station A. The north line is marked at the right hand top corner of the sheet by the compass.

- ii. With the help of the alidade touching the point a The ranging rod at B is bisected and ray is drawn . the distance AB is measured and plotted to any suitable scale. So the point b is represents station B
- iii. The table is shifted and set up over B. It is leveled and centered so that b is just over B. Now the alidade is placed along the line ba, and the ranging rod at A is bisected by turning the table clockwise or anticlockwise. At this time the centering may be disturbed and should be adjusted immediately if required .When the centering, leveling and bisection of ranging rod at A are perfect, then the orientation is said to be perfect.

**b. Magnetic needle Method:-**This method is suitable when the local attraction is not suspected. The following steps are followed during the magnetic needle method.

- i. Suppose A and B are two station . The plane table set up over A. The table is leveled by the spirit level and centered by the U- Fork so that the point a is just over station A. The north line is marked at the right hand top corner of the sheet by the compass in such a way that the needle coincides with 0-0 mark . after this a line representing the north line is drawn through the edge of the compass box. Then the table is clamped.
- ii. With the help of the alidade touching the point a The ranging rod at B is bisected and ray is drawn . the distance AB is measured and plotted to any suitable scale. So the point b is represents station B
- iii. The table is shifted and set up over B. It is leveled and centered so that b is just over B. The table is leveled. Now the compass is just exactly over the north line drawn previously. The table is then turned clockwise or anticlockwise until the needle coincides with 0-0 mark of the compass. While turning the table it should be kept in mind that the centering and leveling is not disturbed. In case it is disturbed it should be adjusted immediately.
- iv. When the centering and leveling are perfect and the needle is exactly at 0-0 mark , the orientation is said to be perfect.

### Methods Of Plane Table.-

There are four methods of plane table. They are

- Radiation
- Intersection
- Traversing
- Resection

### Radiation:-

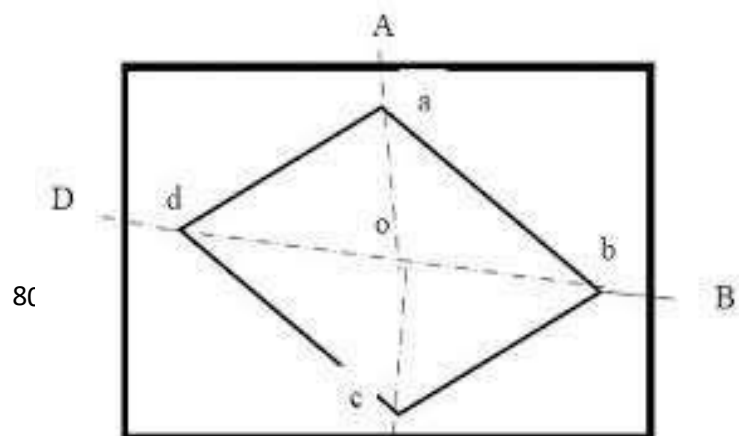



This method is suitable for locating the objects from a single station.

In this method rays are drawn from the station to the objects and the distances from the station to the object are measured and plotted to any suitable scale along the respective rays.

Procedure:-

- i. Suppose O is a station on the ground from where the objects A, B, C, & D are visible.
- ii. The plane table set up over at P. A drawing sheet is fixed on the table, which is then leveled and centered. A point  $o$  is selected on the sheet to represent the point  $o$ .
- iii. The North line is marked on the right hand top corner of the drawing sheet with the trough compass.
- iv. With the alidade touching the point  $o$ , Ranging rod at A, B, C, & D are bisected and the rays are drawn.
- v. The distances OA, OB, PC, & OD are measured and plotted to any suitable scale to obtain the points a, b, c, & d representing A, B, C, & D on the paper.

### Intersection:-

This method is suitable for locating inaccessible points by the intersection of the ray drawn from two station instrument station.

Procedure:-

- i. Suppose A & B are two stations and P is an object on the far bank of the river. It is required to fix the position of P on the sheet by the intersection of the rays drawn from A and B.
- ii. The table is set up at A. It is leveled and centered so that a point  $a$  on the sheet is just over the station A. The North line is marked on the right hand top corner of the drawing sheet with the trough compass.
- iii. With the alidade touching the point  $a$  the object P and the ranging rod at B are bisected and rays are drawn through the fiducial edge of the alidade.
- iv. The distance AB is measured and plotted to any suitable scale to obtain the point  $b$ .
- v. The table is shifted and centered over B and leveled properly. Now the alidade is placed along the line  $ba$  and orientation is done by back sighting. While backsighting it should be kept in mind that the centering and leveling is not disturbed. In case it is disturbed it should be adjusted immediately.
- vi. With the alidade touching  $b$ , the object P is bisected and ray is drawn. Suppose this ray intersects the previous ray at a point  $p$ . This point  $p$  is the plotted position of P.

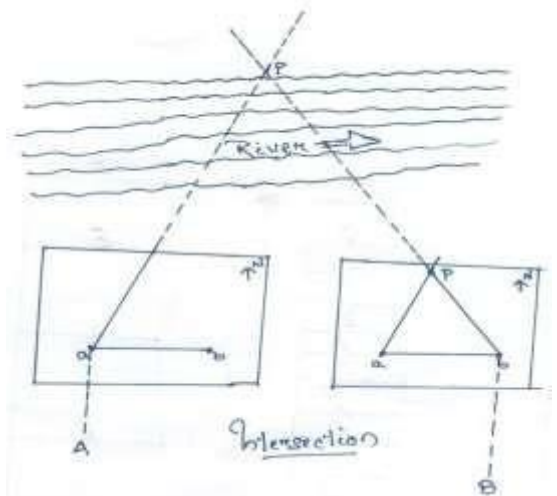

### Traversing:-

This method is suitable for connecting the traverse station

**Procedure:-**

- i. Suppose the P,Q,R,& S are the traverse stations.
- ii. The table is set up at the station P. A suitable point is selected on the drawing sheet let it be *p*. such that the whole area may plotted on the drawing sheet..the table well leveled, centered and the north line is marked on right hand top corner of the sheet.
- iii. With the alidade touching the point *p* the ranging rod at *Q* is bisected and ray is drawn . The distance PQ is measured and plotted to any suitable scale to obtain the point *q*
- iv. The table is shifted and set up over the station *Q*. It is then well leveled, centered , and oriented by back sighting and clamped.
- v. With the alidade touching the point *q* the ranging rod at *R* is bisected and the ray is drawn . The distance QR is measured and plotted to any suitable scale to obtain the point *r*
- vi. The table is shifted and set up over the station *R*. It is then well leveled, centered , and oriented by back sighting and clamped .
- vii. With the alidade touching the point *r* the ranging rod at *S* is bisected and the ray is drawn . The distance RS is measured and plotted to any suitable scale to obtain the point *s*
- viii. The table is shifted and set up over the station *S*. It is then well leveled, centered , and oriented by back sighting and clamped.
- ix. With the alidade touching the point *s* the ranging rod at *P* is bisected and the ray is drawn.
- x. At the end the finishing point may not coincide with the starting point and there may be closing error. This error is adjusted graphically by Bowditch's rule.
- xi. After making the correction for closing error the table is again setup over at *A*. After (well leveled, centered , and oriented by back sighting the surrounding are located by radiation).

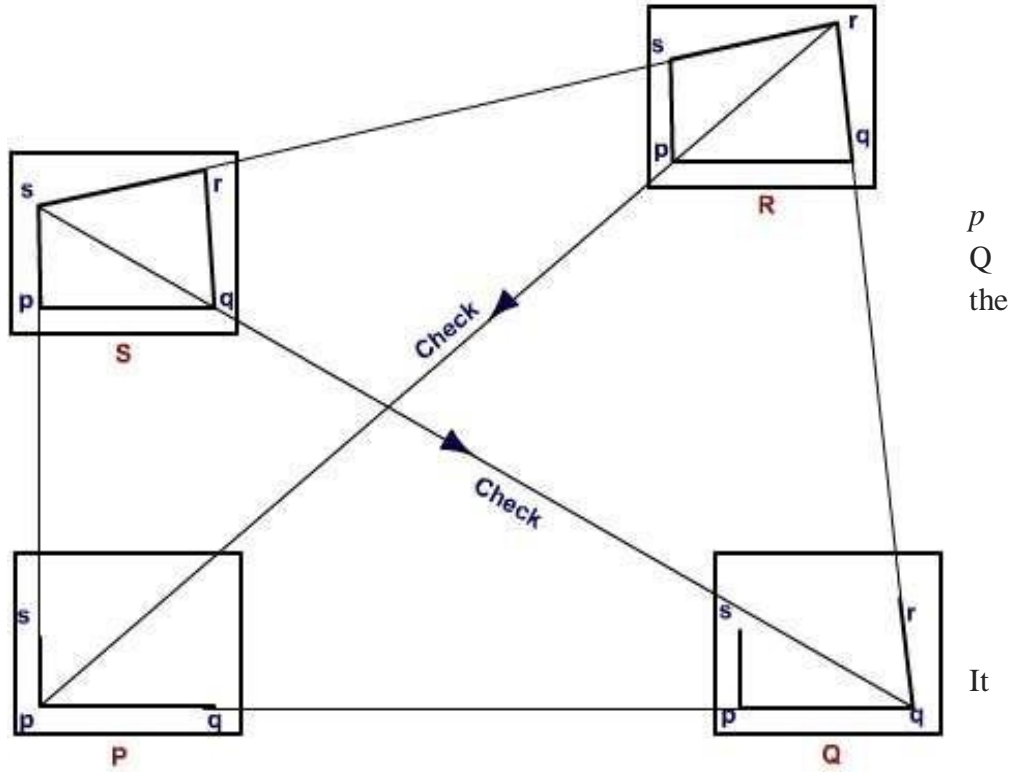

- xii. The table is then shifted and set up at all station of the traverse and proper adjustments the details are located by the radiation and intersection methods.

### **Resection method:-**

This method is suitable for establishing new stations at a place in order to locate missing details.

### **Procedure**

(a) Suppose it is required to establish a station at position on P. Let us select two points A and B on the ground. The distance AB is measured and plotted to any suitable scale. This line AB is known as the “base line”.

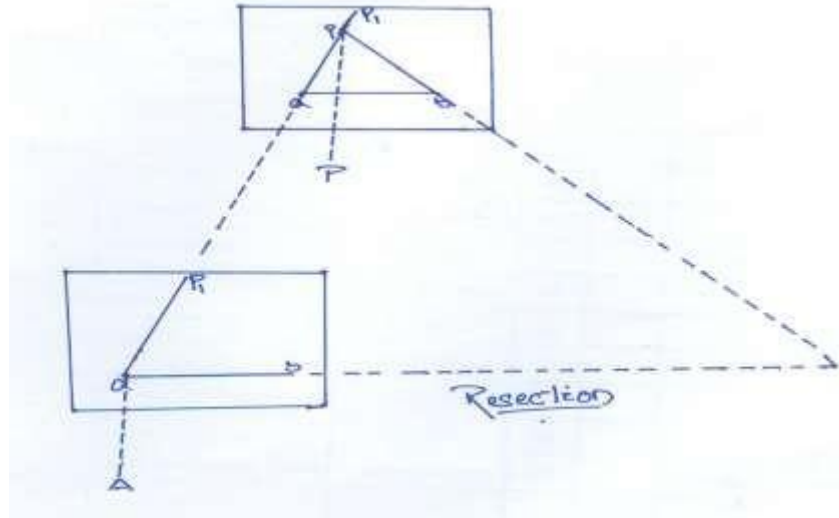

(b) The table is set up at A. It is leveled; centered and oriented by bisecting the ranging rod at B. the table is then clamped.

(c) With the alidade touching point a, the ranging rod at P is bisected and a ray is drawn. Then a point  $P_1$  is marked on this ray by estimating with the eye.

(d) The table is shifted and centered in such a way that  $P_1$  is just over P. It is then oriented by back sighting the ranging rod at a.

(e) With the alidade touching point b, the ranging rod at B is bisected and a ray is drawn. Suppose this ray intersects the previous ray at a point P. This point represents the position of the station P on the sheet. Then the actual position of the station P is marked on the ground by U-fork and plumb bob.

Resection method based on (1) the two-point problem, and (2) the three-point problem.

### **1. Two point problem:-**

In problem, two well defined points whose position have already been plotted on the plan and selected. then by perfectly bisecting these points a new station is established at the required position.

## Procedure:-

**A. Suppose** A and B are two well defined points whose position are plotted on map as  $a$  and  $b$  .it is required to locate a new station at P by perfectly bisecting A and B

b. An auxiliary station Q is selected at a suitable position on the ground. The table is set up at Q and it is leveled; centered and oriented by an eye estimate. It is then clamped.

c. With the alidade touching  $a$  and  $b$  the points A and B are bisected and a ray is drawn suppose these ray meet at  $q$

d. with the alidade centered on  $q$  the ranging rod at A is bisected and a ray is drawn . Then by eye estimation a point  $p_1$  is marked on this ray.

e. The table is then shifted and centered on P with  $p_1$  just over P. It is then leveled and oriented by the backighting. With the alidade touching the point  $a$  the point A is bisected and the ray is drawn . Suppose this ray intersects at  $q_1$  at the point  $q_1$  as assumed previously.

f. With the alidade centered on  $p_1$  the point B is bisected and a ray is drawn .Suppose this ray intersect the ray qb at a point  $b_1$ . The triangle  $abb_1$  is known as triangle of error and is to be eliminated.

g. The alidade placed along the line  $ab_1$  and a ranging rod R is fixed at some distance from the table. Then the alidade placed along the line  $ab$  and the table is turned to bisect R. at this position the table is said to be perfectly oriented.

(h) Finally, with the alidade centered on p and q , the points p and Q are bisected and rays are drawn. Suppose these rays intersect at a point a. This would represent the exact position of the required station A. Then the station A is marked on the ground.

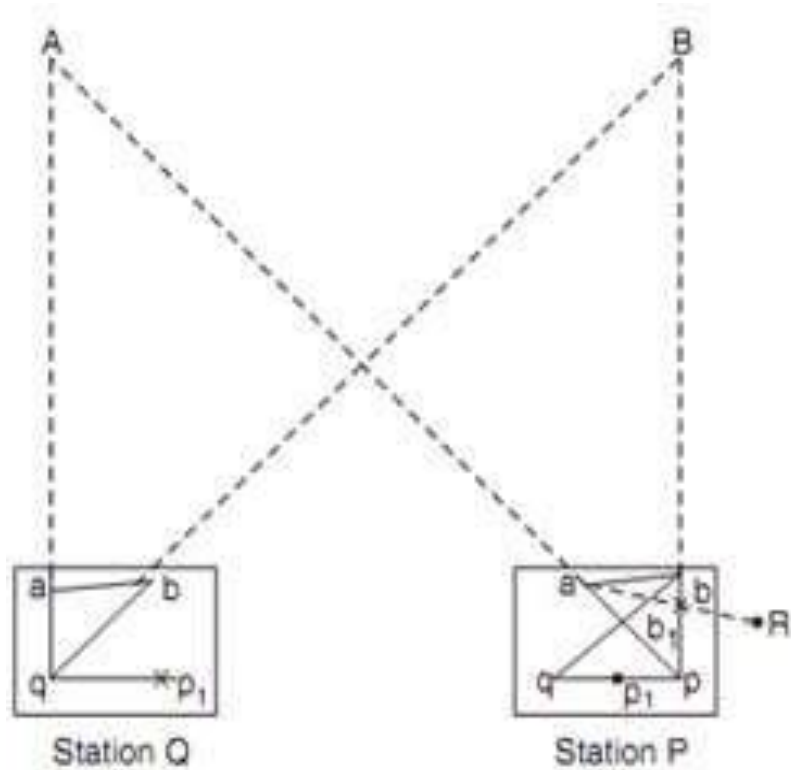

## 2. The Three-point problem :-

in this problem, three well defined points are selected whose positions have already been plotted on the map. Then, by perfectly bisecting these three well-defined points, a new station is established at the required position.

No auxiliary station is required in order to solve this problem. The table is directly placed at the required position.

The problem may be solved by three methods (a) the graphical or Bessel's method, (b) the mechanical method, and (c) the trial and error method.

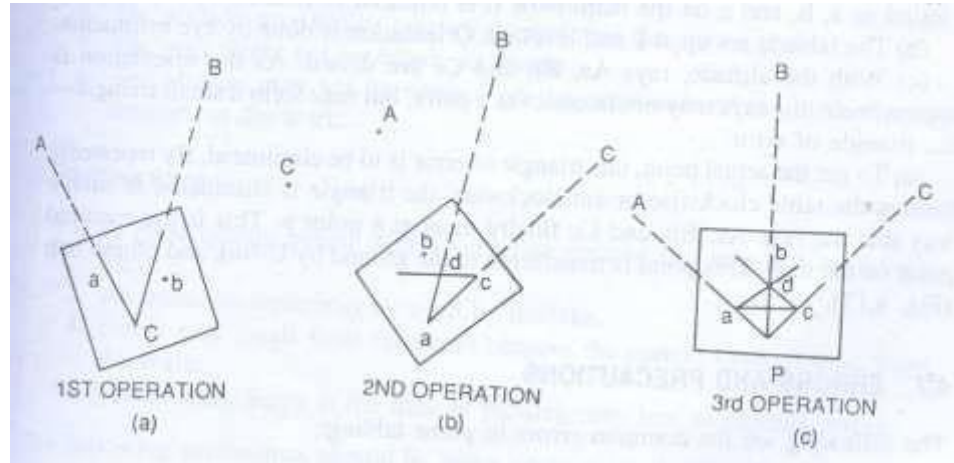

(a) The Graphical method

(1) Suppose A, B and C are three well-defined points which have been plotted as a, b and c. Now it is required to locate a station at P.

(2) The table is placed at the required station P and leveled. The alidade is placed along the line ca and the point A is bisected and ray drawn.

(3) Again the alidade is placed along the line ac and the point c is bisected and the table is clamped. With the alidade touching a, the point b is bisected and a ray is drawn. Suppose this ray intersects the previous ray at a point d .

The alidade is placed along db and the point B is bisected. At this position the table is said to be perfectly oriented. Now the rays Aa, Bb and Cc are drawn. These three rays must meet at a point p which is the required point on the map. This point is transferred to the ground by U-fork and plumb bob.

## Errors and Precautions:-

### A. Instrumental Errors

1. The surface of table may not be perfectly level.
2. The fiducial edge the alidade might not be straight.
3. The vanes may not be vertical.
4. The horsehair may be loose and inclined.
5. The table may be loosely joined with the tripod stand.
6. The needle of the through compass may not be perfectly balanced. Also it may not be able to move freely due to sluggishness of the pivot point.

### B. Personal Errors

1. The leveling of the table may not be perfectly.
2. The table may not be centred properly.
3. The orientation of the table may not be proper.
4. The table might not be perfectly clamped.
5. The objects may not be bisected perfectly.
6. The alidade may not be correctly centred on the station point.
7. The rays might not be drawn accurately.
8. The alidade may not be centred on the same side of the station point throughout the work.

### C. **Plotting Error**

1. A good quality pencil with a very fine pointed end may not have been used.
2. An incorrect scale may be used by mistake.
3. Errors may result from failure to observe the correct measurement from the scale.
4. Unnecessary hurry at the time of plotting may lead to plotting errors.

The following precautions should be taken while using the plane table;

1. Before starting the work the equipments for survey work should be verified. Defective accessories should be replaced by perfect equipment.
2. The centering should be perfect.
3. The leveling should be proper.
4. The orientation should be accurate.
5. The alidade should be centred on the same side of the station-pin until the work is completed.
6. While shifting the plane table from one station to another, the tripod stand should be kept vertical to avoid damage to the fixing arrangement.
7. Only the selected scale should be on the table.
8. Measurements should be taken carefully from the scale while plotting.
9. The stations on the ground are marked A, B, C, D etc. while the station points on the map are marked a, b, c, d etc.

Procedure of Field work

#### 1. **Reconnaissance** –

The area to be surveyed is thoroughly examined to find the best possible way for traversing. The traverse stations should cover the whole area and should be indivisible. The provisions for check lines should be kept in mind.

#### 2. **Marking the stations**

The selected stations are marked on the ground by wooden pegs. Reference sketches should be prepared for the stations so that they can be readily located in case the station pegs are removed.

## **CHAPTER-6**

### **THEODOLITE SURVEYING AND TRAVERSING**

#### **INTRODUCTION**

An instrument used for measuring horizontal and vertical angles accurately, is known as a theodolite. Theodolite is also used for prolongation or survey line, finding difference in elevation and setting out engineering work requiring higher precision I.e. ranging the highway and railway curves, aligning tunnels, etc.

#### **PARTS OF A TRANSIT THEODOLITE: -**

1) **Leveling head:** - It consists of two parts i.e. upper tribarch and lower tribarch.

- (i) **The upper tribarch:** - It has three arms. Each arm carries a leveling screw. Leveling screw is provided for supporting leveling the instrument. The boss of the upper tribarch is pierced with a female axis in which lower male vertical axis operates.
- (ii) **The lower tribarch:** - It has a circular hole through which a plumb bob may be suspended for centering the instrument quickly and accurately.

The three distinct functions of a leveling head are:

- (i) To support the main part of the instrument.
- (ii) To attach the theodolite to the tripod.
- (iii) To provide a means for leveling the theodolite.

2) **Lower plates (or scale plate).** The lower plate which is attached to the outer spindle carries a horizontal graduated circle at its beveled edge. It is therefore sometimes known as the scale plate. It is divided into  $360^\circ$ . Each degree is further divided into ten minutes or twenty minutes arc intervals. Scale plate can be clamped at any position by clamping screw and a corresponding slow motion can be made with a tangential screw or slow motion screw. When the lower clamp is tightened, the lower plate is fixed to the upper tribarch of the leveling head. The size of the theodolite is determined by the size of the diameter of the lower plate.

3) **Upper plate (or vernier plate):** - The upper plate or vernier plate is attached to the inner spindle axis. Two verniers are screwed to the upper plate diametrically opposite. This plate is so constructed that it overlaps and protects the lower plate containing the horizontal circle completely except at the parts exposed just below the verniers. The verniers are fitted with magnifiers. The upper plate supports the Ys or As which provide the bearings to the pivots of the telescope. It carries an upper clamp screw and a corresponding tangent screw for accurately fixing to the lower plate on clamping the upper clamp and unclamping the lower clamp, the instrument may be rotated on this outer spindle without any relative motion between two plates. On the other hand if the lower clamp screw is tightened and

upper

clamp

screw is unclamped, the instrument may be rotated about the inner spindle with relative motion between the vernier and the graduated scale of the lower plate. This property is utilized for measuring the angle between two settings of the instrument. It may be ensured that the clamping screws are properly tightened before using the tangent screws for a finer setting.

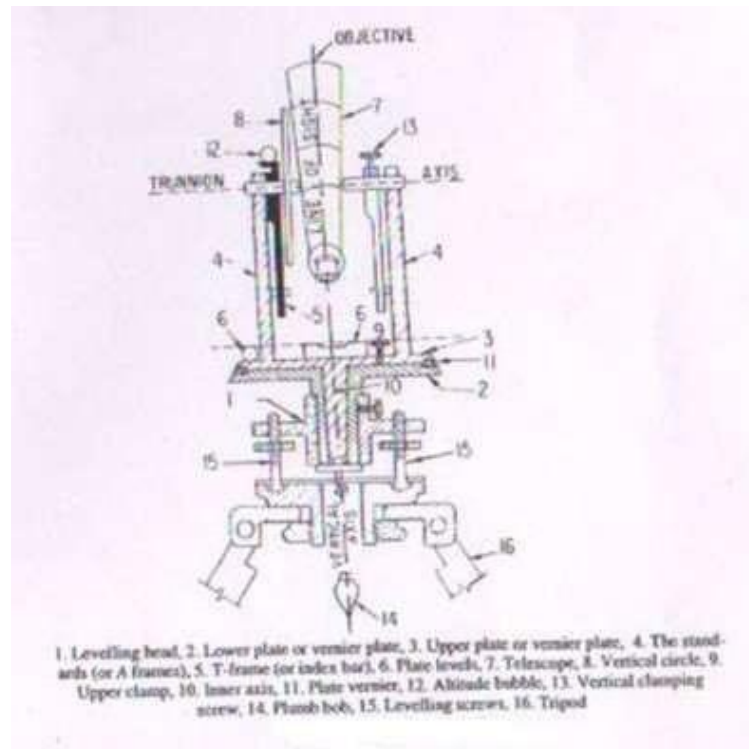

Fig.3.1 Shows parts of transit theodolite

- 4) **The standards (or A frame):** - Two standards resembling the English letter A are firmly attached to the upper plate. The tops of these standards form the bearing of the pivots of the telescope. The standards are made sufficiently high to allow the rotation of the telescope on its horizontal axis in vertical plane. The T-frame and the arm of vertical circle clamp are also attached to the standards.
- 5) **T-frame or index bar:** - It is T-shaped and is centered on the horizontal axis of the telescope in the frame of the vertical circle. The two verniers C and D are provided on it at the ends of the horizontal arms, called the index arm. A vertical leg known as clipping arm is provided with a fork and two clipping screw at its lower extremity. The index and clipping arms together are known as T-frame. At the top of this frame, if attached a bubble tube which is called the altitude bubble tube.
- 6) **Plate levels:** - The upper plate carries two plate levels placed at right angles to each other. One of the plate bubbles is kept parallel to the trunnion axis. The plate levels can be centered with the help of the foot screws. In some theodolites only one plate level



is provided.

- 7) **Telescope:** - The telescopes may be classified as
  - (i) The external focusing telescope

- (ii) The internal focusing telescope.

## DEFINITIONS AND OTHER TECHNICAL TERMS

Following terms are used while making observations with a theodolite.

1. **Vertical axis:**-The axis about which the theodolite, may be rotated in a horizontal plane, is called vertical axis. Both upper and lower plates may be rotated about vertical axis.
2. **Horizontal axis:**- The axis about which the telescope along with the vertical circle of a theodolite, may be rotated in vertical plane, is called horizontal axis. It is also sometimes called trunnion axis or traverse axis.
3. **Line of collimation:** - The line which passes through the intersection of the cross hair of the eye piece and optical center of the objective and its continuation is called line of collimation. The angle between the line of collimation and the line perpendicular to the horizontal axis is called error of collimation.

The line passing through the eye piece and any point on the objective is called line of sight.

4. **Axis of telescope:** - The axis about which the telescope may be rotated is called axis of telescope.
5. **Axis of the level tube:** - The straight line which is tangential to longitudinal curve of the level tube at its center is called the axis of the level tube. When the bubble of the level tube is central, the axis of the level tube becomes horizontal.

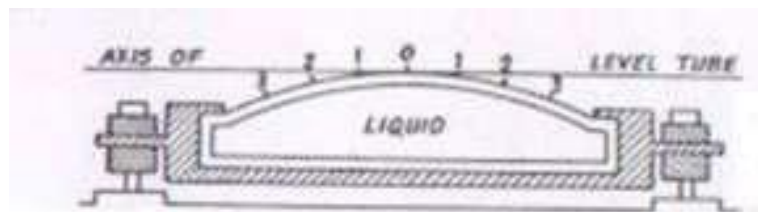

Fig.3.2 Cross section of level tube

6. **Centering:** - The process of setting up a theodolite exactly over the ground station mark, is known as centering. It is achieved when the vertical axis of the theodolite is made to pass through the ground station mark.
7. **Transiting:** - The process of turning the telescope in vertical plane through  $180^\circ$  about its horizontal axis is known as transiting. The process is also sometimes known as reversing or plunging.
8. **Swing:** - A continuous motion of the telescope about the vertical axis in horizontal plane is called swing. The swing may be in either direction i.e. left or right. When the telescope is rotated in the clockwise direction, it is known as right swing. If it is

rotated in the anticlockwise left direction it is known as leftswing.

9. **Face left observations:** - When the vertical circle is on the left of the telescope at the time of observations, the observations of the angles are known as face left observations.
10. **Face right observations:** - When the vertical circle is on the right of the telescope at the time of observations, the observations of the angles are known as face right observations.
11. **Changing face:**-It is the operation of changing the face of the telescope from left to right and vice-versa.
12. **Telescope normal:** - Telescope is said to be normal when its vertical circle is to its left and the bubble of the telescope is up.
13. **Telescope inverted:** - A telescope is said to be inverted or reversed when its vertical circle is to its right and the bubble of the telescope is down.

### FUNDAMENTAL LINES OF A TRANSIT THEODOLITE

The fundamental lines of a transit theodolite are:

- 1) The vertical axis
- 2) The axis of plate bubble
- 3) The line of collimation which is also sometimes called line of sight.
- 4) The horizontal axis, transverse axis or trunnion axis.
- 5) The bubble line of telescope bubble or altitude bubble.

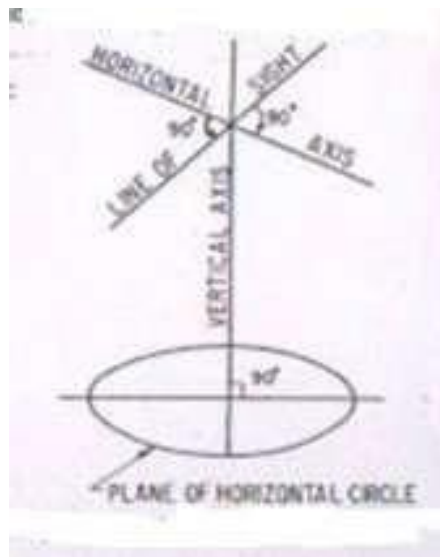

Fig.3.3 Fundamental lines of transit theodolite

## **ADJUSTMENTS OF THEODOLITE**

The adjustments of theodolites are of two kinds.

1. Temporary adjustment
2. Permanent adjustment

**Temporary adjustments:** The adjustments which are required to be made at every instrument station before making observations are known as temporary adjustments.

The temporary adjustments of a theodolite include the following:

- i. Setting up the theodolite over the station.
- ii. Leveling of the theodolite
- iii. Elimination of the parallax.
  - 1) **Setting up:** - The operation of setting up a theodolite includes the centering of the theodolite over the ground mark and also approximate leveling with the help of tripod legs.
  - 2) **Centering:** - The operation with which vertical axis of the theodolite represented by a plumb line, is made to pass through the ground station mark is called centering.

The operation of centering is carried out in following steps:

- i. Suspend the plumb bob with a string attached to the hook fitted to the bottom of the instrument to define the vertical axis.
- ii. Place the theodolite over the station mark by spreading the legs well apart so that telescope is at a convenient height.
- iii. The centering may be done by moving the legs radially and circumferentially till the plumb bob hangs within 1cm horizontally of the station mark.
- iv. By unclamping the center shifting arrangement, the finer centering may now be made.

#### **Approximate leveling with the help of the tripod:**

It is very necessary to ensure that the level of the tripod head is approximately level before centering is done. In case there is a considerable dislevelment, the centering will be disturbed when leveling is done. The approximate levelling may be done either with reference to a small circular bubble provided on the tribarch or by eye judgment.

**Leveling of a theodolite:** The operation of the making the vertical axis of a theodolite truly vertical is known as leveling of the theodolite.

After having leveled approximately and centered accurately, accurate leveling is done with the help of plate levels. Two methods of leveling are adopted to the theodolites, depending upon the number of leveling screws.

**Levelling with three screw head:** - The following steps are involved

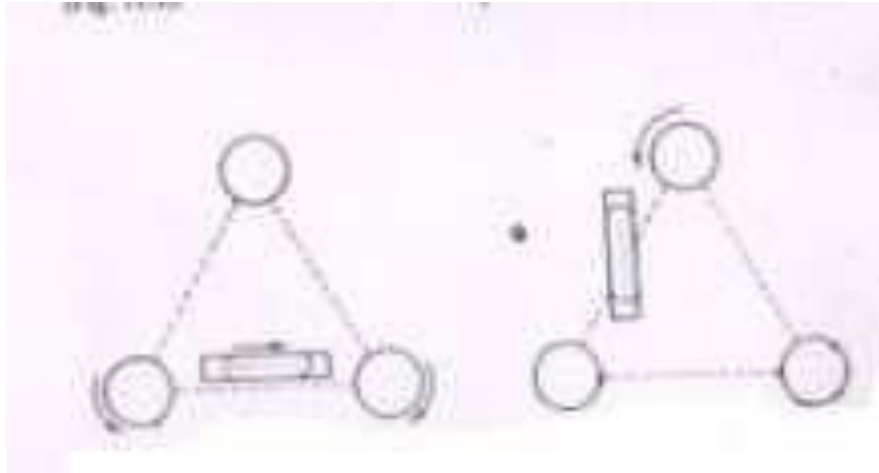

Fig.3.4 Leveling of a theodolite with a three screwhead

- 1) Turn the horizontal plate until the longitudinal axis of the plate level is approximately parallel to line joining any two leveling screws [fig(a)].
- 2) Bring the bubble to the center of its run by turning both foot screws simultaneously in opposite directions either inwards or outwards. The movement of the left thumb indicates the direction of movement of the bubble.
- 3) Turn the instrument through  $180^\circ$  in azimuth.
- 4) Note the position of the bubble. If it occupies a different position, move it by means of the same foot screws to the approximate mean of the two positions.
- 5) Turn the theodolite through  $90^\circ$  in azimuth so that the plate level becomes perpendicular to the previous position [fig.(b)].
- 6) With the help of the third foot screw move the bubble to the approximate mean position already indicated.
- 7) Repeat the process until the bubble retains the same position for every setting of the instrument in azimuth.

The mean position of the bubble is called the zero of the level tube. If the theodolite is provided with two plate levels placed perpendicular to each other, the instrument is not required to be turned through  $90^\circ$ . In this case, the longer plate level is kept parallel to any two foot screws and the bubble is brought to central position by turning both the foot screws simultaneously. Now with the help of the third foot screw, bring the bubble of second plate level central. Repeat the process till both the plate bubbles occupy the central position of their run for all the positions of the instrument.

**ELEMENTATION OF PARALLAX:** - An apparent change in the position of the object caused by change in position of the surveyor's eye is known as parallax.

In a telescope parallax is caused when the image formed by the objective is not situated in the plane of the cross hairs. Unless parallax is removed accurate bisections and sighting of



objects become difficult.

Elimination of parallax may be done by focusing the eye piece for distinct vision of cross hairs and focusing the objective to bring the image of the object in the plane of the cross-hairs as discussed below.

**Focusing the eye piece:** To focus the eye-piece for distinct vision of cross hairs, either holds a white paper in front of the objective or sight the telescope towards the sky. Move the eye piece in or out till the cross hairs are seen sharp and distinct.

**Focusing the objective:** After cross hairs have been properly focused, direct the telescope on a well defined distant object and intersect it with vertical wire. Focus the objective till a sharp image is seen. Removal of the parallax may be checked by moving the eye slowly to one side. If the object still appears intersected, there is no parallax.

If, on moving the eye laterally, the image of the object appears to move in the same direction as the eye, the observer's eye and the image of the object are on the opposite sides of the vertical wire. The image of the object and the eye are brought nearer to eliminate the parallax. This parallax is called farparallax.

If, on the other hand, the image appears to move in reverse direction to the movement of the eye, the observer's eye and the image of the object are on the same side of the vertical wire and the parallax is then called near parallax. It may be removed by increasing the distance between the image and the eye.

### **MISCELLANEOUS USES OF THEODOLITE:**

Theodolites are commonly used for the following operations.

- i. Measurements of horizontal angles.
- ii. Measurements of vertical angles.
- iii. Measurements of magnetic bearing of lines.
- iv. Measurements of direct angles.
- v. Measurements of deflection angles.
- vi. Prolongation of straight lines.
- vii. Running a straight line between two points.
- viii. Laying off an angle by repetition method.

### **Measurement of horizontal angles**

- 1) **To measure the angle by method of repetition:-**

Let  $\angle ABC$  be the required angle between sides  $BA$  and  $BC$  to be measured by repetition method as shown in Fig 3.5. When the measure of an angle is small, slight error in its sine value introduce a considerable error in the computed sides as the sine value of the angle changes rapidly. Therefore, for accurate and precise work, the method of repetition is generally used. In this method, The value of the angle is added several times mechanically and the accurate value of the angular measure is determined by dividing the accumulated reading by the number of repetition.



Fig. 3.5 Method of repetition

- 2) **To measure the angle by reiteration method:** When several angles having a common vertex, are to be measured the reiteration method is generally adopted. In this method angles are measured successively starting from a reference station and finally closing on the same station. The operation of making last observation on the starting station is known as closing horizon. Making observations on the starting station twice provides a check on the sum of all angles around a station. The sum should invariably be equal to  $360^\circ$ , provided the instrument is not disturbed during observations. As the angles are measured by sighting the stations in turn, this method is sometimes known as direction method of observation of the horizontal angles.
2. **Measurement of vertical angles:** A vertical angle may be defined as the angle subtended by the inclined line of sight and the horizontal line of sight at the station in vertical plane. If the point sighted is above the horizontal axis of the theodolite, the vertical angle is known as angle of elevation and if it is below, it is known as angle of depression.
 

**Procedure:** To measure a vertical angle subtended by the station B at the instrument station A, The following steps are involved:

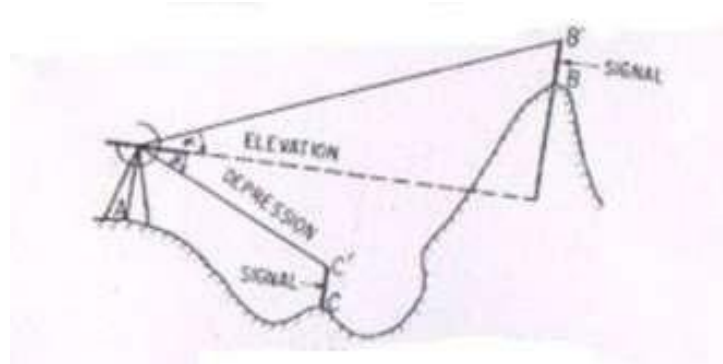
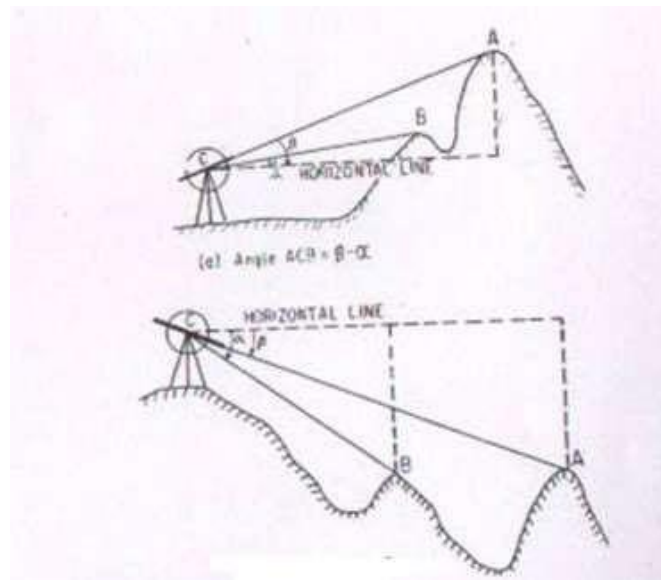

Fig. 3.6.Measurement of vertical angle.

- i. Set up the theodolite over the ground station mark A. Level it accurately by using the altitude bubble.
  - ii. Set the zero of the vertical vernier exactly in coincidence with zero of the vertical scale using vertical clamp and vertical tangent screw. Check up whether the bubble of the altitude level is central of its run. If not, bring it to the centre of its run by means of the clip screw. In this position, the line of collimation of the telescope is horizontal and the verniers read to zero.
  - iii. Loosen the vertical circle clamp and move the telescope in vertical plane until the station B is brought in field of view. Use vertical circle tangent screw for accurate bisection.
  - iv. Read both the verniers of the vertical circle. The mean of two vernier readings gives the value of the vertical angle.
  - v. Change the face of the instrument and make the observations exactly in similar way as on the face left.
  - vi. The average of two values of the vertical angle is the required value of the vertical angle.
3. **Measurement of magnetic bearing of a line:** To measure the magnetic bearing of a line AB, the theodolite should be provided with either a circular or a trough compass. The following steps are involved:
- (i) Centre and level the instrument accurately on station A.
  - (ii) Set the vernier to read zero.
  - (iii) Loosen the lower plate and also release the magnetic needle.
  - (iv) Swing the telescope about its vertical axis until the magnetic needle points S-N graduations of the compass box scale.
  - (v) Clamp the lower plate. Using the lower tangent screw bring the needle exactly against the zero graduation in exact coincidence with the north end of the needle.
  - (vi) In this position, the line of collimation of the telescope lies in the magnetic meridian at the place while verniers still reads to zero. The setting of the

instrument is now said to be oriented on the magneticmeridian.



(b) Angle  $ACB = \alpha - \beta$

Fig. 3.7 Measurement of vertical angle

- (vii) Loosen the upper plate, swing the instrument and bisect B accurately, using the upper tangentscrew.

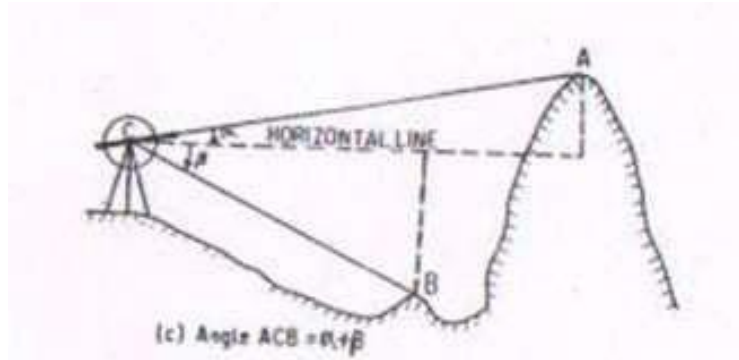

Fig. 3.7 Measurement of vertical angle

- (viii) Read both the vernier. The means of the two readings is the required magnetic bearing of the line AB.
  - (ix) Change the face of the instrument and observe the magnetic bearing exactly in a similar way as on the left face.
  - (x) The mean of magnetic bearings observed on both faces is the accurate value of the magnetic bearing of line AB.
4. **Measurement of direct angles:** The angle measured clockwise from the preceding line to the following line is called a direct angle. These angles are also sometimes known as azimuths from the back line, or angles to the right and may vary from  $0^\circ$  to  $360^\circ$ .

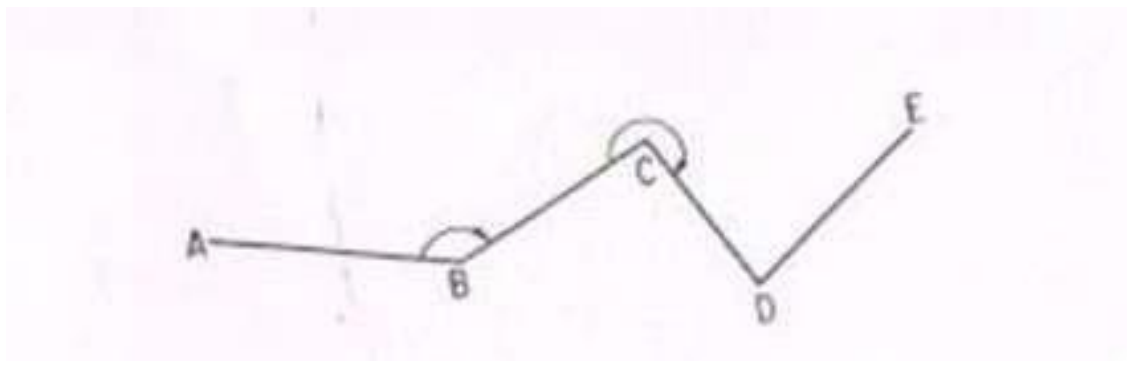

Fig. 3.8 Measurement of direct angles

5. **Measurement of deflection angles:** The angle which any survey line makes with the prolongation of the preceding line is called deflection angle. Its value may vary from  $0^\circ$  to  $180^\circ$  and is designated as right deflection angle if it is measured in clockwise direction and as left deflection angle if it is measured in an anticlockwise direction. In fig. the deflection angles  $\alpha$  and  $\delta$  at stations B and E respectively are left deflection angles whereas angles  $\beta$  and  $\gamma$  at stations C and D are right deflection angles.

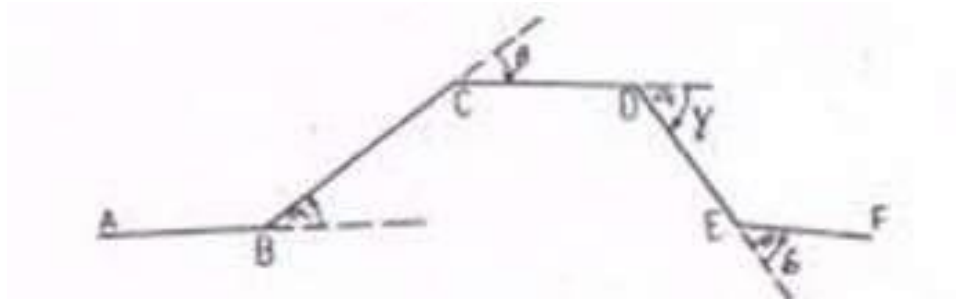

Fig. 3.9 Measurement of deflection angles

6. **Prolongation of a straight line:** Prolongation of any straight line AB to a point F may be done by any one of the following methods:

**First method: -**

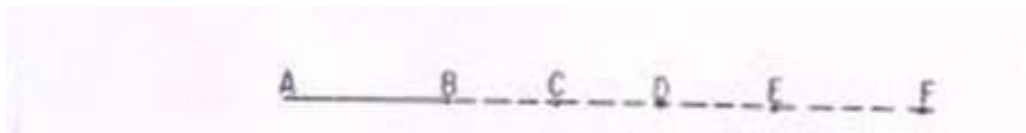

Fig. 3.10 Prolongation of a line

The following steps are involved:

- i. Set up the theodolite at A, center and level it accurately.



- ii. Bisect an arrow centered over the mark at B.
- iii. Establish a point C in the line of sight at a convenient distance.
- iv. Shift the instrument to B.
- v. Centered the theodolite over B, level it and sight C. Establish another point D.
- vi. Proceed in a similar manner until the desired point F is established.

**Second method:-**

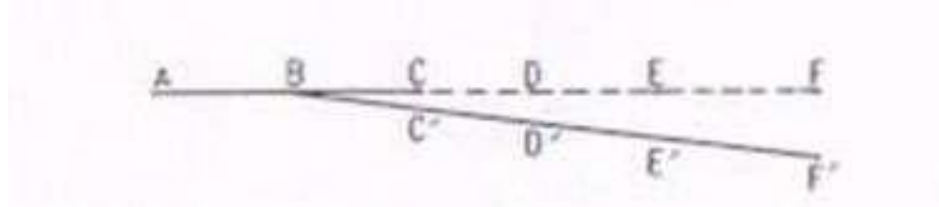

Fig. 3.11 Prolongation of a line

The following steps are involved:

- I. Set up the theodolite at B and centered it carefully.
- II. Bisect A accurately and clamp both the plates.
- III. Plunge the telescope and establish a point C in the line of sight.
- IV. Shift the instrument to C and center it carefully.
- V. Bisect B and clamp both the plates.
- VI. Plunge the telescope and establish the point D in the line of sight.
- VII. Continue the process till the last point F is established.

NOTE:-

The following points may be noted.

- I. If the instrument is in perfect adjustment, the points B, C, D, E and F will lie in a straight line.
- II. If the line of collimation is not perpendicular to the horizontal axis, the established points C', D', E' and F' would lie on a curve.

### Third method: -

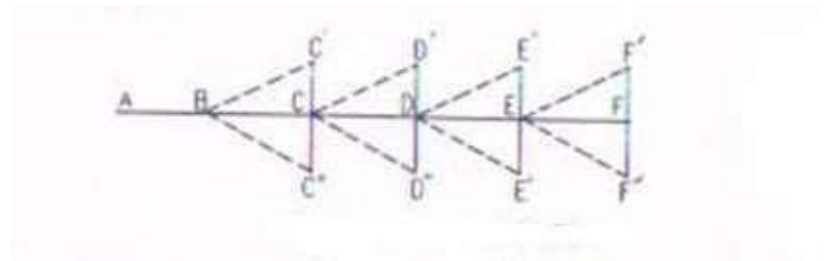

Fig. 3.12 Prolongation of a line

Following steps are involved

- I. Set up the theodolite at B and center it carefully.
- II. Bisect A on face left and clamp both the plates.
- III. Plunge the telescope and establish a point C'.
- IV. Change the face and bisect A again.
- V. Plunge the telescope and establish a point C'' at the same distance as C' from B.
- VI. If the instrument is in adjustment, the point C' and C'' will coincide.
- VII. If not establish a point C midway between C' and C''.
- VIII. Shift the instrument to C and repeat the process to establish a point D.
- IX. Repeat the process until the required point F is established.

NOTE: - The following points may be noted.

- I. This method of prolongation of a line requires two sightings and as such it is known as double sighting method.
- II. This method is used only when greater precision is required with a poorly adjusted instrument.

**SOURCES OF ERROR IN THEODOLITE WORK:** The sources of error in theodolite work may be broadly divided into three categories, i.e.

1. Instrument error.
2. Personal error
3. Natural errors

**Instrumental errors:** - The theodolites are very delicate and sophisticated surveying instrument. In spite of best efforts during manufacturing perfect adjustment of fundamental axes of the theodolite, is not possible. The unadjusted errors of the instrument are called residual errors. We shall now discuss how best to avoid the effect of these residual error while making field observations. Instrumental errors may also be divided into different types

as discussed below:

1. **Error due to imperfect adjustment of plate level:** - If the plate bubbles are not adjusted properly, the vertical axis of the instrument does not remain vertical even if plate bubbles remain at the center of their run. Non verticality of the vertical axis introduced error in the measurements of both the horizontal and vertical angles. Due to non verticality of vertical axis the horizontal plate gets inclined and it does not remaining in horizontal plane. The error is especially important while measuring the horizontal angles between stations at considerable different elevations.

**Elimination of the error:** - this error can be eliminated only by leveling the instrument carefully, with the help of the altitude or telescope bubble, before starting the observations.

2. **Error due to line of collimation not being perpendicular to the trunnion axis:**  
- If the line of collimation of the telescope is not truly perpendicular to the trunnion axis, it generates a cone when it is rotated about the horizontal axis. The trace of the intersection of the conical surface with the vertical plane containing the station sighted the hyperbolic. This imperfect adjustment introduces errors in horizontal angles measured between stations at different elevations.

#### **Personal errors:**

Personal errors are due to mainly following causes.

- (i) inaccurate centring over a station
- (ii) slip of instrument when not put firmly on the tripod
- (iii) faulty manipulation of instrument controls like clamping the instrument and operating wrong tangent screw
- (iv) inaccurate leveling, inaccurate bisection of target
- (v) non-verticality of ranging rod
- (vi) displacement of target stations, parallax
- (vii) errors in sighting, reading and recording

#### **Natural errors**

Errors due to natural causes include the followings.

- (i) settlement of tripod due to soft soil
- (ii) wind causing vibrations and turning
- (iii) high temperature causing faults in reading due to refraction, differential expansion of different parts
- (iv) direct sunlight on the instrument making sighting and reading difficult.

## TRAVERSING

After the field work is over, the positions of different points are plotted on a map with reference to lines  $XX_1$  and  $YY_1$  as shown in fig. which are perpendicular and parallel to the meridian and are called “axes of coordinates”. The point of intersection of these lines,  $O$ , is called the “origin”. This origin may either be any traverse station or entirely outside the survey area. The distances of various points from  $YY_1$  and  $XX_1$  are called the “x-coordinates” and “y-coordinates” respectively. The coordinates of various traverse stations can be used for calculations of the area of the closed traverse and also for checking the field measurements

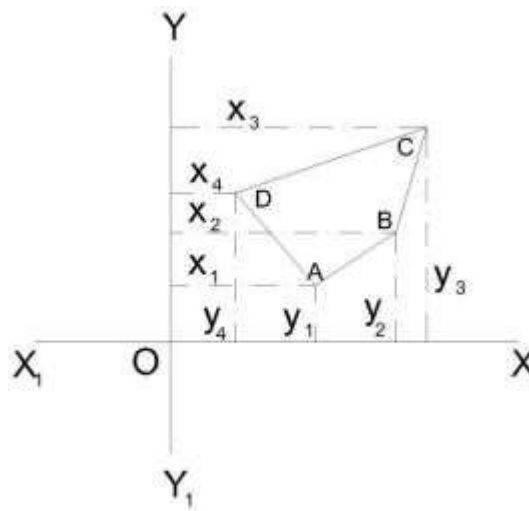

### Traverse computation

If the length and bearing of a line are known, the projection of such a traverse line may be obtained on the line parallel to the meridian  $YY_1$ , and on the line perpendicular to the meridian  $XX_1$ .

#### Latitude:

The projection of the line parallel to the meridian (N-S line) is called the “latitude” of the line.

#### Departure:

The projection of the line perpendicular to meridian (N-S line) is called the “departure” of the line.

The latitude when measured upward or northward along the meridian, is positive and termed as “northing” and when it is measured downward or southward along the meridian it is negative and is called “southing”.

The departure when measured eastward or towards right, is positive and is known as “easting” and when it is measured westward or to the left, it is negative and is known as “westing”.

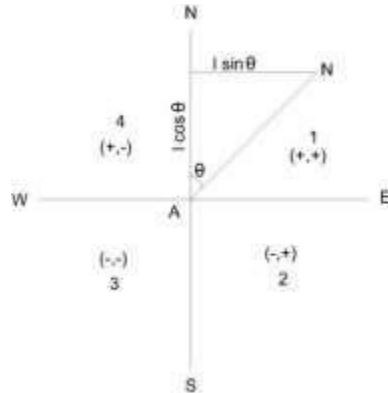

### Traverse computation

if the length of line AB is known and its reduced bearing from meridian (i.e,  $\theta$ ) is known, the latitude and the departure may be determined.

Latitude of a line = Length of line x The cosine of reduced bearing of line  
 = Length x  $\cos \theta$

Departure of a line = Length of line x The sine of reduced bearing of line  
 = Length x  $\sin \theta$

The letter N or S of the reduced bearing will give the sign of the latitude as +ve or -ve respectively and the letter E or W will give the sign of the departure as +ve or -ve, respectively. If the bearings of various traverse lines have been measured as whole circle bearings, the same should be expressed in the form of reduced bearings and consequently can be utilized in determining the latitudes and the departures.

The following table in such a case, may be used.

Whole circle bearing (WOB)	Quadrant	Sign of	
		Latitude	Departure
0° to 90°	(1) or NE	+	+
90° to 180°	(2) or SE	-	+
180° to 270°	(3) or SW	-	-
270° to 360°	(4)	+	-

### Consecutive and independent coordinates

The latitude and departure of any point with reference to the preceding point are known as “consecutive coordinates”. And the coordinates of any point with reference to a common origin are called the “independent coordinates” of the point. The independent coordinates are also known as “total latitude” and “total departure” of the points.

The independent coordinates of any point may be determined by adding (algebraically) the latitudes and departures of the lines between that point and the origin. Thus,

x-coordinate (or total = x-coordinate of the first point of the departure) of any point

traverse+ Algebraic sum of the departures of the lines between the first point and that point

y-coordinate (or total = y-coordinate of the first point of the traverse + Algebraic sum of latitudes of the lines between the first point and that point

The above rule follows that

x-or y-coordinate of last point of the traverse = x. or y-coordinate of the first point + Algebraic sum of all departures or Latitudes

Note

The theodolite traverse should always be plotted with the help of rectangular coordinates.

**Adjustment of closing errors in a closed traverse:**

If the survey work is correct, in a closed traverse, the algebraic sum of latitudes (I e,  $\Sigma L$ ) should be equal to zero and also the algebraic sum of departures (I e,  $\Sigma D$ ) should be equal to zero. It follows that the sum of northings should be equal to sum of southings and the sum of eastings should be equal to sum of westings.

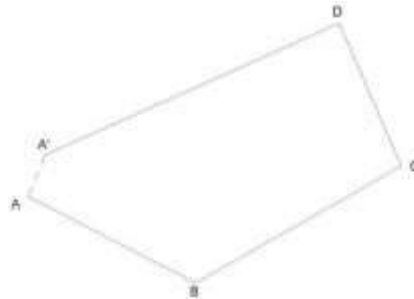

closing errors in a closed traverse

There are always errors in a theodolite traverse mainly due to two sources, viz :

- (1) the angles between the sides, and
- (2) the lengths of the sides.

Out these, the first is usually less important than the second. The traverse is plotted according to the field measurements, the same will not close on paper and the end point of the traverse will not coincide exactly with the starting point. The distance by which the last point of the traverse falls short to coincide with the starting point is called the “error of closure” or “closing error”. As per the Fig shows plotting of traverse ABCD. The traverse is not closing at A but instead it ends at some other point A1 and thus AA1 is the closing error. The components of this error A1A2 and AA2 as in Fig parallel and perpendicular to the meridian may be obtained by finding the algebraic sum of the latitudes  $\Sigma L$ , and the algebraic sum of departures  $\Sigma D$ .

$\Delta AA1A2$  is right-angle at A2 .

Linear error of closure  $AA1 = \sqrt{\dots}$

Where  $\Phi$  is the reduced bearing.

The signs of  $\Sigma L$  and  $\Sigma D$  will determine the position of closing in a particular quadrant.

The closing error is usually expressed as a fraction having the numerator as unity and is called the relative error of closure.

**Note**

The errors in lengths of sides are more likely to occur along the longest sides of the traverse.

**Angular error**

If the angles of a traverse do not add up correctly, ie, a difference exists between the sum of the measured angles and the theoretical sum of  $(2n\pm 4)$  right angles, where n is the number of sides of closed traverse ; necessary correction to the angles nearest the short sides (since these are the angles most likely to be slightly more in error) is to be applied. If the angular error is small, the same may be arbitrarily distributed to two or three angles. If the survey work is carried out with ordinary precision, the correction applied to any angle is not less than the least count of the vernier.

**.3 Adjustment of error in bearings**

The closing error in bearing may be obtained by comparing the two bearings of the last line as observed at the first and the last stations of the traverse or if the traverse ends on a line of known bearing, the closing error can be obtained by finding the difference between its observed bearing and known bearing. This error ..... then, should be distributed among the sides of the traverse. If n is the number of sides, the corrections to the bearings of the sides will be as given below :

- Correction to the first bearing =
- Correction to the second bearing =
- Correction to the third bearing =
- Correction to the last bearing =

**BALANCING THE TRAVERSE**

When the closing error in latitude and in departure is determined, the latitudes, and departures should be adjusted such that the algebraic sum of the latitudes should be adjusted such that the algebraic sum of the latitudes and departures should each be equal to zero. This operation of applying correction to the latitudes and the departures is called the “balancing of the traverse”. If one or more sides of a traverse have not been measured with equal care due to some typical field conditions, the whole or the largest part of the error may be adjusted to the same side or sides. But, if all the sides have been measured with equal precision and care, the following rules may be applied to determine the corrections for balancing the traverse.

(1) Bowditch’s rule

The Bowditch’s Rule or the “compass rule” is generally used to balance the traverse when the angular as well as linear measurements are taken with equal precision. By this rule, the total error in latitude and in departure is distributed in proportion to the length of



thesides.

Correction to the latitude or to the departure of any line

= Total error in latitude or departure

X Length of the line

Perimeter of the traverse

The traverse can also be adjusted as it is explained in “compass traverse adjustment”.

(2) Transit rule

The transit rule may be applied to balance the traverse when the angular measurements are taken with greater care and precision than the linear measurements as in the case of a theodolite and stadia traverse. According to this rule,

Correction to latitude of any line

= Total error in latitude X Latitude of that line

Arithmetical sum of all the latitudes

Similarly,

Correction to departure of any line

= Total error in departure X Departure of that line

Arithmetical sum of all the departure

(3) Third rule

According to the third rule,

Correction to northing of any side

= Total error in latitude X Northing of that side

Sum of all northings

Correction to southing of any line

= Total error in latitude X southing of that side

Sum of all southings

Similarly,

Correction to easting of any side

= Total error in departure X Easting of that side

Sum of alleasting

Correction to westing of any side

= Total error in departure X Westing of that side

Sum of all wrstings

When the traverse is thus balanced, the lengths and bearings of lines are changed.

Note

In case the traverse adjustments are made by the Bowditch's Rule, angles are changed more and the lengths are charged less than when the adjustment is made by the transit rule.

**Gales Traverse Table:**

The following steps may observed.

- (1) Find out the sum of the observed included angles which should be equal to  $(2n \pm 4)$  right angles according as the interior or exterior angles are measured. If they are not

- equal, apply the necessary corrections to the angles so that the sum of the corrected angles is exactly equal to  $(2n \pm 4)$  right angles.
- (2) From the observed bearing of the first line AB and the corrected included angles, calculate the WCB of all the other lines BC, CD, etc. As a check, find out the bearing of the first line which should be equal to its observed bearing.
  - (3) Calculate the reduced bearings of lines from the whole circle bearing and find out the respective quadrants.
  - (4) Compute the latitudes and departures of lines, i.e., the consecutive coordinates (coordinates with respect to preceding point, e.g., in a closed traverse ABCD, the coordinates of A, with respect to D and coordinates of B with respect to station A, and so on) from their observed lengths and corrected reduced bearings. For example in the above traverse, to compute the coordinates of A, the length and reduced bearing of line DA should be taken, and similarly for point B, the length and reduced bearing of line AB should be considered.
  - (5) Find out the algebraic sum of latitudes ( $\Sigma L$ ) and that of departures ( $\Sigma D$ ). Apply necessary corrections to the latitudes and departures so that their sum is equal to zero for closed traverse.
  - (6) From the corrected consecutive coordinates, obtain the independent coordinates of the lines such that they are all positive and the whole traverse lies in the first quadrant (NE).

#### Example

The following corrected latitudes and departures correspond to the sides of a traverse ABCDE. Compute the independent coordinates.

Lines	Latitude		Departure	
	Northing	Southing	Easting	Westing
AB		325.16	620.24	
BC	449.35		946.24	
CD	980.25			742.60
DE		536.89		797.80
EA		567.55		26.08

The independent coordinates of an origin or the starting point A of the survey should be so chosen that the coordinates of all other station points are positive, i.e. all the points of the traverse lie in the first quadrant.

Also the chosen independent coordinates should be in multiples of 100 and 1000.

Here, the coordinates of point A may be chosen as (400,0). Applying the rule,

North coordinate of point A = 400.00  
 Deduct southing of point B = 325.16  
 North coordinate of point B = 78.84

Add northing of point C

=449.35

North coordinate of point C	= 524.19
Add northing of point D	= 980.25
North coordinate of point D	= 1504.44
Deduct southing of point E	=536.89
North coordinate of point E	= 967.55
Deduct southing of point A	= 567.55
North coordinate of point A	= 400.00 (same as assumed)
East coordinate of point A	= 0.00
Add easting of point B	= 620.24
East coordinate of point B	= 620.24
Add easting point C	= 946.24
East coordinate of point C	= 1 566.48
Deduct westing of point D	= 742.60
East coordinate of point D	= 823.88
Deduct westing of point E	= 797.80
East coordinate of point E	= 26.08
Deduct westing of point A	= 26.08
East coordinate of pointA	= 0.00 (same as assumed)

**Area of closed traverses:**

The following methods are generally used for calculating the area of closed traverses :

- a)Area from coordinates (y and x).
- a) Area from latitudes and doublemeridian.
- b)Area from departures and totallatitudes.

**a) Area of closed traverses from coordinates:**

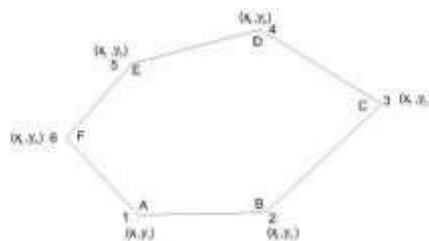

If the coordinates  $(x_1, y_1)$ ,  $(x_2, y_2)$ , etc. of various points in a closed traverse are known, the area can be easily calculated.

In Fig ABCDEF is a closed traverse of six sides and the coordinates are also indicated for each station.

To find the area, multiply (ordinate/abscissa) by the difference of (abscissae/ordinates) of the points before and after the point considered, e.g., when point A is considered, the ordinate of point A is multiplied by the difference of abscissae of points B and F, i.e.,  $y_1(x_2 - x_6)$ .

Always the preceding abscissae/ordinates are subtracted from the following abscissae/ordinates.

Find the sum of all such products which is equal to twice the area of the traverse.

Half of this sum gives the required area of the traverse.

Thus, the area of closed traverse is given below:

$$\text{Area} = \frac{1}{2}[y_1(x_2 - x_6) + y_2(x_3 - x_1) + y_3(x_4 - x_2) + y_4(x_5 - x_3) + y_5(x_6 - x_4) + y_6(x_1 - x_5)]$$

$$\text{Area} = \frac{1}{2}[y_1(x_2 - x_6) + y_2(x_3 - x_1) + y_3(x_4 - x_2) + \dots + y_n(x_{n+1} - x_{n-1})]$$

Where  $x_1, x_2, x_3$ , etc. are the abscissae and  $y_1, y_2, y_3$  etc. are the ordinates. The

abscissae or x-coordinates are along X-axis or east-west line.

The ordinates or y-coordinates are along Y-axis or north-south line.

#### b) Area of closed traverse from latitudes and double meridian distances (DMD):

The meridian distance (MD) of a line or “longitude” is the perpendicular distance of the middle point of the line from the reference meridian.

The double meridian distance (DMD) or the double longitude of a line is equal to the sum of the meridian distance of the two ends of the lines. The MD of various lines can be calculated by the following principles:

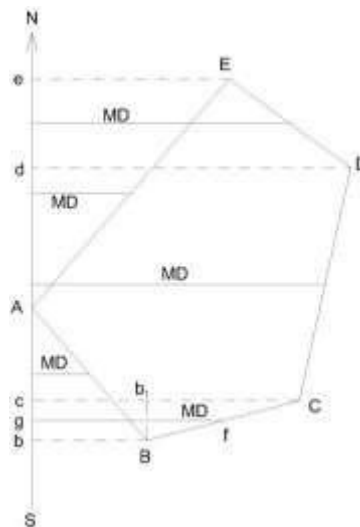

(1) The DMD of first line is equal to the departure of thatline.

(2) The DMD of each succeeding line is equal to DMD of the preceding line plus the departure of the line itself.

(3) The DMD of the last line is numerically equal to the departure of the last line but with opposite sign.

**Rule**

To find out the area of the closed traverse by latitudes and DMD, multiply each DMD by the latitude of that line.

Find the algebraic sum of all these products which gives twice the area of the traverse.

Half of this sum is equal to the required area of traverse.

The figure clearly shows the meridian distance from the reference meridian.

For example, the meridian distance of line BC will be  $f g$  and the DMD of line BC is  $(C_c + B_b)$ .

$$= C_b + B_b \cdot (C_c + B_b) = C_b C_c + B_b C_c + B_b^2$$

$$= C_b C_c + B_b C_c + B_b^2 = (B_b + C_c) C_c$$

$$\text{DMD of line BC} = \text{DMD of line AB} + \text{Departure of line AB} + \text{Departure of line BC}$$

It proves the given principal.

**c) Area of closed traversed from departures and total latitudes:**

To find out the area of closed traverse by this principal proceed as follows:

- (1) Find out the total latitude of each station of the traverse.
- (2) Find the algebraic sum of departures of the two lines meeting at that station.
- (3) Multiply the total latitude of that station by the corresponding algebraic sum of the departures.

(4) Find the algebraic sum of these products which is equal to twice the area of the traverse. Example

The latitudes and departures of the survey lines of a traverse ABCD are given as follows:

Line	Latitude		Departure	
	N	S	E	W
AB	204.6		113.9	
BC		234.9	205.8	
CD		150.7	86.0	
DA	181.0	233.7		



Calculate its area if the sides are measured in meters.

**(1) Area of traverse ABCD by coordinates (independent):**

The independent coordinates can be calculated as already explained. Here, the independent coordinates of A can be assumed as (200,0) so that all the coordinates are positive and the traverse may lie in first quadrant only. The coordinates can be tabulated as given below.

Line	Latitude	Departure	Station	Independent coordinates	
				North, Y	East, x
AB	+ 204.6	+ 113.9	A	200.0	0.0
BC	- 234.9	+ 205.8	B	404.6	113.9
CD	- 150.7	- 86.0	C	169.7	319.7
DA	+ 181.0	- 233.7	D	19.0	233.7
		Cheek :	A	200.0	0.0

Now, the area of the traverse

$$\begin{aligned} &= \frac{1}{2}[y_1(x_2 - x_4) + y_2(x_3 - x_1) + y_3(x_4 - x_2) + y_4(x_1 - x_3)] \\ &= \frac{1}{2}[200(113.9 - 233.7) + 404.6(319.7 - 0.0) \\ &+ 169.7(233.7 - 113.9) + 19(0.0 - 319.7)] \\ &= \frac{1}{2}[200 \times -119.8 + 404.6 \times 319.7 + 169.7 \times 119.8 + 19 \times -319.7] \\ &= \frac{1}{2}[-23\,960.0 + 129\,350.62 + 20\,330.06 - 6\,074.30] \\ &= \frac{1}{2}[149\,680.68 - 30\,034.30] = \frac{1}{2}[119\,646.38] = 59\,823.19 \\ \therefore \text{Area of the traverse ABCD} &= 59\,823.19 \text{ m}^2 \end{aligned}$$

**(2) Area of traverse ABCD by latitudes and double meridian distance:**

In this method, first of all the DMD of each line should be calculated.

$$\text{DMD of line AB} = \text{Departure of line AB} = 113.9$$

$$\begin{aligned} \text{MD of line BC} &= \text{DMD of line AB} + \text{Departure of line B} + \text{Departure of BC} \\ &= 113.9 + 113.9 + 205.8 = 433.6 \end{aligned}$$

$$\begin{aligned} \text{DMD of line CD} &= \text{DMD of line BC} + \text{Departure of line BC} + \text{Departure of line Cd} \\ &= 433.6 + 205.8 - 86.0 = 639.4 - 86.0 = 553.4 \end{aligned}$$

$$\begin{aligned} \text{DMD of line DA} &= \text{DMD of line CD} + \text{Departure of line CD} + \text{Departure of line DA} \\ &= 553.4 - 86.0 - 233.7 = 553.4 - 319.7 \end{aligned}$$

= 233.7

Check

The DMD of last line DA should be numerically equal to its departure but should be of opposite sign.

Hence, the above calculations are correct.

Now, the results may be tabulated as follows:

Line	Latitude	Departure	Twice the area(Column 2 X Column 4)		
			+	-	
1	2	3	4	5	6
AB	+ 204.6	+ 113.9	113.9	23 303.94	
BC	- 234.9	+ 205.8	433.6		101 852.64
CD	- 150.7	- 86.0	553.4		83 379.38
DA	+ 181.0	- 233.7	233.7	42 299.70	
		Total		65 603.64	185 250.02
		Algebraic sum		119 646.38	

$$\begin{aligned} \therefore \text{Area of traverse ABCD} &= \frac{1}{2} \times \text{Algebraic sum} \\ &= \frac{1}{2} \times 119\,646.38 = 59\,823.19\text{m}^2 \end{aligned}$$

Note

The negative sign of the has no significance.

**(3) Area of traverse ABCD from departures and totallatitudes:**

Here, station A can be assumed as the reference station and the total latitudes of other stations B, C and D are calculated.

$$\text{Total latitude of station A} = \Sigma L = 00$$

$$\text{Total latitude of station B} = \Sigma L = +204.6$$

$$\text{Total latitude of station C} = \Sigma L = 204.6 - 234.9 = -30.3$$

$$\text{Total latitude of station D} = \Sigma L = 204.6 - 234.9 - 105.7 = - 181.0$$

Check.

$$\text{Total latitude of station A} = \Sigma L = 204.6 - 234.9 - 105.7 + 181.0 = 0.0$$

The results may be tabulated as under:

Twice the area

Line	Latitude	Departure	Total latitude	Algebraic sum of adjoining	departure		
1	2	3	4	5	6	7	8
AB	+204.6	+113.9	B	+204.6	+319.7	65 410.62	
BC	-234.9	+205.8	C	-30.3	+119.8	3 629.94	
CD	-150.7	-86.0	D	-181.0	-319.7	57 865.70	
DA	+181.0	-233.7	A	0.0	-119.8	0.0	
Total						123 276.32	3629.94

Algebraic sum 119 646.38

$$\begin{aligned}
 \therefore \text{Area of the traverse} &= \frac{1}{2} \times \text{Algebraic sum} \\
 &= \frac{1}{2} \times 119\,646.38 \\
 &= 59\,823.19 \text{ m}^2
 \end{aligned}$$

Types of problems in traversing

While solving the problems, the following trigonometrically relationship should be remember and employed according to need.

The trigonometrically relationship of the course of a line together with its latitude and departure are employed are follows:

- (1) Latitude = Length X cosine of reduced bearing
- (2) Departure = Length X sine of reduced bearing
- (3) Tangent of reduce bearing =  $\frac{\text{Departure}}{\text{Latitude}}$
- (4) Length =  $\sqrt{(\text{Latitude})^2 + (\text{Departure})^2}$

Length = Latitude X secant of reduced bearing

Length = Departure X cosecant of reduced bearing

The various types of problems may be as follows :

- (a) To find out the length and bearing of a line joining two-points whose independent coordinates are given :

In such a case proceed as given below:

(1) Find the difference between the north coordinates;

- (2) Find the difference between the east coordinates;
- (3) Then, if  $\theta$  be the reduced bearing of the line joining the two points,

$$\begin{aligned} \tan \theta &= \frac{\text{Departure of the line}}{\text{Latitude of the line}} \\ &= \frac{\text{Difference between the east coordinates}}{\text{Difference between the north coordinates}} \end{aligned}$$

### **Omitted or missing measurements:**

If the length and bearing of each side of the closed traverse are known, the traverse may be said to be completely surveyed. The bearing of all the sides may either be observed in the field or these may be computed from the observed bearing of any one line and the deflection angles or included angles of the traverse. It is always advisable to find out the length and bearings of the sides of a closed traverse by field measurements. But it is not always possible and due to certain obstacles direct measurements cannot be taken sometimes. For example such a difficulty may be experienced in direct observation of length and bearing of a line joining two points which are not inter visible owing to an intervening obstruction like a building. Similar difficulty may also be experienced if omissions occur in the field notes. To overcome these difficulties, the method of latitudes and departures may be readily employed to determine the omitted measurements provided the omitted measurements are not more than two in number. If the omitted measurements are more than two in number, the problem becomes indeterminate.

The sides of which the length or bearing or both are omitted, are called “affected sides”. The solution of problems of missing measurements is based on the principle that in a closed traverse the algebraic sum of the latitudes ( $\Sigma L$ ) and that of departures ( $\Sigma D$ ) should each be equal to zero.

Mainly there are two types of problems, viz :

- (1) In which only one side is affected, e g:
  - (a) The bearing of one side may be missing;
  - (b) The length of one side may be missing ;and
  - (c) The length and bearing of one side may be missing.
- (2) In which two sides are affected, e g:
  - (a) The length of one side and bearing of another side may be missing;
  - (b) The bearings of two sides may be missing ;and
  - (c) The lengths of two sides may be missing.

To solve all such problems, the trigonometrical relationships, which are already given, should be used.

The following procedure may be adopted for these cases:



Case 1

In this case, the bearing, or length, or bearing and length of one side is missing. Let in Fig the length or the bearings or both the length and bearing of line ED be missing. Then, to determine the missing parts, adopt the following procedure.

Calculate the latitudes and departures of the other known sides EA, AB, BC and CD taking into account the correct signs. Find out the sum of latitudes ( $\Sigma L$ ) and that of departures ( $\Sigma D$ ). Then from the condition of closed traverse, the latitude and departure of the affected side will be  $-\Sigma L$ , and  $-\Sigma D$  respectively. Calculate the bearing of the affected side from the relationship,  $\tan \text{ of RB} = \frac{\Sigma \text{Departure}}{-\Sigma \text{Latitude}}$ ,

and the length of the affected side from the relationships,  $\text{Length} = \sqrt{(\Sigma \text{Latitude})^2 + (\Sigma \text{Departure})^2}$ , or  $\text{Length} = \text{Latitude} \times \text{secant of RB}$ , or  $\text{Length} = \text{Departure} \times \text{cosecant of RB}$ .

Case 2

(a) Length of one side and bearing of another side omitted

Let in Fig 7.69, the length of line BC and bearing of line CD be omitted. To solve such problems proceed as given below:

- (1) Join B and D to form a closed polygon DEAB, leaving the affected sides. Calculate the length and bearing of closing line BD as in case 1.
- (2) Compute the angle ( $\alpha$ ) between the closing line BD and line BC from their calculated and known bearings respectively.
- (3) Now, in  $\Delta BCD$ , the lengths of sides BD and CD are known and angle  $\alpha$  is known. Angle  $\gamma$  and length of side BC may be calculated by applying the sine rule.

When  $\gamma$  is calculated from the above relationships, angle  $\beta$  may also be calculated,  $\beta = 180^\circ - (\alpha + \gamma)$

- (4) From the known bearing of side BC and the calculated value of angle  $\gamma$ , calculate the required bearing of line CD. Check the result by calculating the bearing of line CD from the calculated values of bearing of line DB and angle  $\beta$ .

(b) Bearing of two sides missing

Refer Fig 7.69 and let BC and CD be the sides whose bearings are not known. Proceed as given below:

- (2) Now since the lengths of all the sides in  $\Delta BCD$  are known the area of triangle BCD may be calculated easily by the well-known formula:

$$\text{Area, } \Delta = \sqrt{s(s-a)(s-b)(s-c)}$$

Where  $s$  is half the perimeter of the triangle and  $a, b, c$  are the lengths of the sides of the triangle.

- (3) Since the bearings of sides BC and CD are not known, angles  $\alpha, \beta$  and  $\gamma$  cannot be calculated with the help of bearings. First of all, the angles should be found out and then the bearings can be easily calculated. Determine the angles by equating the calculated area to half the products of any two sides and the sine of the angle between them, e.g., to find out angle  $\alpha$ , the relationship  $\Delta = \frac{1}{2} BD \times BC \times \sin \alpha$  may be used and soon.
- (4) Next, find out the bearings of sides BC and CD from the known bearing of closing

line BD and the calculated angles  $\alpha$  and  $\beta$ .

(c) Lengths of two sides missing

Refer Fig and let sides BC and CD be affected, I e, let their lengths be not known.

(1) Ignoring the affected sides, close the polygon and calculate the length and bearing of closing line BD.

(2) Here, since the bearings of all the sides in  $\triangle BCD$  are known, angles  $\alpha, \beta$  and  $\gamma$  can be calculated easily. After calculations apply the check :  
 $\alpha + \beta + \gamma = 180^\circ$

(3) Next, compute the lengths of sides BC and CD by applying the sine rule:

$$BC = \frac{BD \times \sin \beta}{\sin \gamma}$$

$$\sin \gamma$$

$$CD = \frac{BD \times \sin \alpha}{\sin \gamma}$$

$$\sin \gamma$$

Notes

(1)

In case, the two sides of a traverse are affected and are not adjacent as shown in Fig (sides 1 and 4), the following procedure should be adopted.

Shift the known sides 5 and 6 parallel to themselves and in the direction parallel to one of the unknown sides and close the polygon by dotted closing line as shown in the figure. The affected side 4 will be thus shifted towards side 1 and will be adjacent to each other. The length and bearing of a line does not change when it is moved parallel to itself.

## **CHAPTER - 7**

### **LEVELLING AND CONTOURING**

#### **LEVELLING**

**Purpose of levelling:** Levelling is the art of finding the relative heights and depths of the objects on the surface of the earth. It is that part of surveying which deals with the measurements in vertical plane.

Levelling is of prime importance to an engineer for the purpose of planning, designing and executing various engineering projects such as roads, Railways, canals, dams, water supply and sanitary schemes etc. The Principle of leveling lies in furnishing a horizontal sight and finding the vertical distances of the points above this line. This is done with the help of a level and a levelling staff respectively.

Definition of terms used in levelling-concepts of level surface, Horizontal surface, Vertical surface, Datum, R.L,B.M.

**Level Surface:** This is a surface parallel to the mean spheroidal surface of the earth is said to be a level surface. The water surface of a still lake is also considered to be a level surface.

**Horizontal Plane/surface:** Any plane tangential to the level surface at any point is known as the horizontal plane. It is Perpendicular to the plumb line.

**Vertical Plane/surface:** Any plane passing through the vertical line is known as the vertical Plane.

**Datum Surface or Line:** This is an imaginary level surface or level line from which the vertical distances of different points (above or below this line) are measured. In India the datum adopted for the Great Trigonometrically Survey (GTS) is the mean sea level (MSL) at Karachi.

**Reduced Level (R.L):** The vertical distance of a point above or below the datum line is known as the reduced level of that point. The R.L of a point may be positive or negative according as the point is above or below the datum.

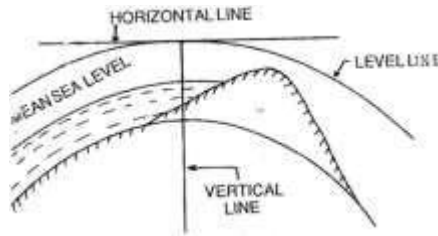

Figure 1.2a

**Bench Mark:** These are fixed points or marks of known RL determined with reference to the datum line. These are very important marks. They serve as reference points for finding the RL of new points or for conducting leveling operations in projects involving roads, Railways.

Bench mark are of four types.(a)**GTS (Great Trigonometric Survey)Bench mark:** This Bench mark s are established by Survey of India at large intervals all over the country(Mumbai). The values of Reduced levels, the relevant positions and the number of benchmarks are given in a catalogue published by this department (Ref.Fig:1.2b )

(b)**Permanent Bench marks:** These are fixed points or marks established by different Government Departments like PWD, Railway, Irrigation, etc. The R.L's of these points are determined with reference to the GTS bench mark., and kept on permanent points like the plinth of building, parapet of a bridge or culvert, and so on. Sometimes they are kept on underground pillars as in**Fig:1.2c**

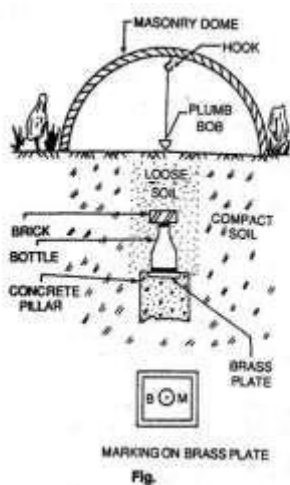

Figure1.2b

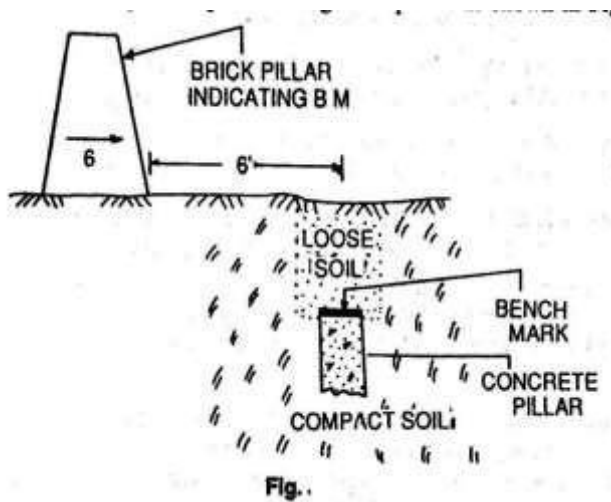

Figure1.2c

(c) **Arbitrary Bench marks:** When the RL's of some fixed points are assumed, they are termed arbitrary bench-mars. These are adopted in small survey operations, when only undulation of the ground surface is required to be determined.

(c) **Temporary Bench marks:** When the bench marks are established temporarily at the end of a day's work, they are said to be temporary bench marks. They are generally made on the root of a tree, the parapet of a nearby culvert, a furlong post, or on a similar place.

:Description of essential features and use of different types of leveling Instruments:

Referring to Fig.

1,2,3-Three tripod legs,3a-triangular plate may be fixed on the top of tripod or detachable from the stand,(4),(5),(6) are three foot screws the foot screw(6)is not visible in the picture,(7) is a magnetic compass,(8) is a screw for holding a magnifying lens,(9)eye piece,(10)the object glass of the telescope covered by a detachable sun shade marked(11),(12)a milled headed screw is used for focusing known as focusing screw.(13) is one of the four capstan screws holding the cross hairs in the diaphragm,(14)main spirit level or longitudinal bubble with marked graduations,(15) a cross level which is smaller in size and is not graduated usually,(16)is, the triangular base, called leveling head (trivet),(17)Tribrach

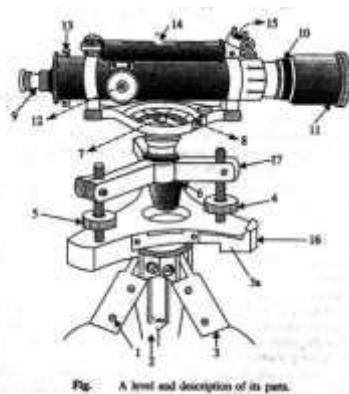

Figure 1.3a

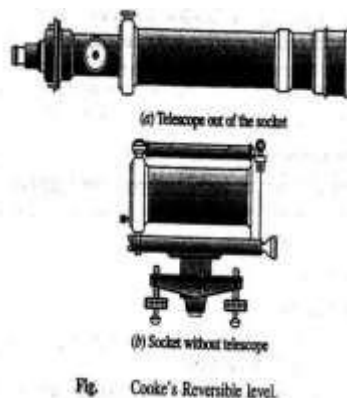

Fig. 1.3b

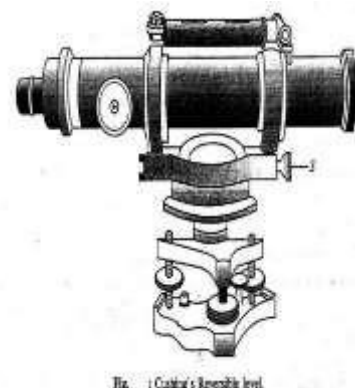

Fig 1.3c

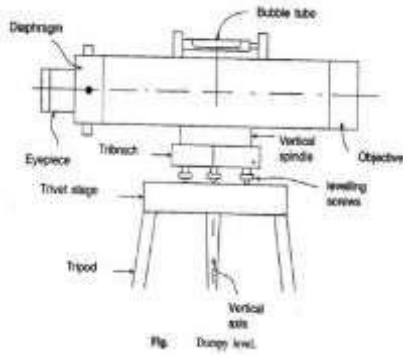

Fig.1.3a

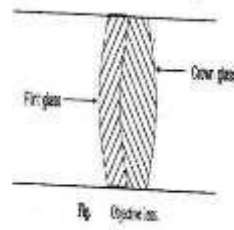

Fig.1.3

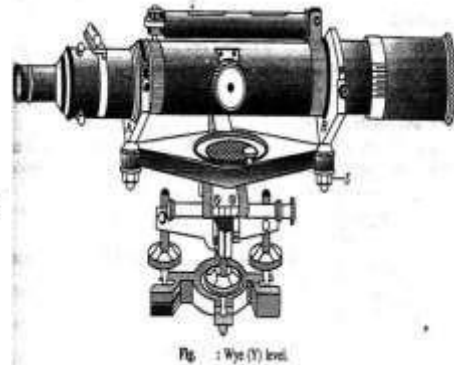

Fig1.3d

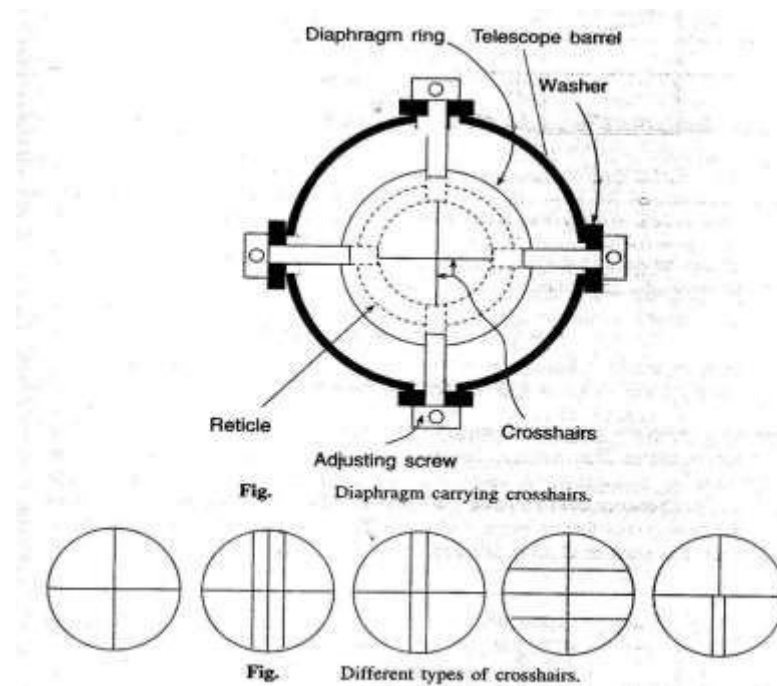

Fig.1.3a

Modifications of dumpy level: Two modified forms of Dumpy level are (1) Cooke's Reversible level and Cushing's reversible level.

**Cooke's reversible level:** The telescope is placed within a socket as such the telescope can be rotated about its longitudinal axis and (ii) can be taken out to be replaced with its ends interchanged in position, (iii) the axis of the telescope can be tilted a little about its transverse



horizontal axis by operating the nut marked “S”.

**Cushing's reversible level:**(i) eye piece carrying the diaphragm and object glass are detachable and, thus, can be interchanged,(ii)Object glass and the eye piece can be rotated about the longitudinal axis of the telescope,(iii)The axis of the telescope can be tilted a little about the horizontal transverse axis of the telescope by operating the nut marked "S".

**Wye(Y) level:** Here the telescope is placed on Y support,(i)the telescope can be taken out of the socket and can be replaced with its ends reversed,(ii)the telescope can be rotated about its longitudinal axis,(iii)the telescope can be a little about its transverse horizontal axis by operating the nut marked "S"

**Tilting level:** The telescope can be tilted about its transverse horizontal axis by operating a screw called tilting screw. The line of collimation, thus can be made horizontal even when the vertical axis of the instrument is not truly vertical. Thus it saves time required for adjustment before taking thereading.

### **Modern levelling Instruments:**

**Automatic Levels:** The manual adjustment is eliminated in the use of auto level. A compensator mechanism is used in the functioning of this level. Only the telescope is approximately level, the compensator is active and the readings can be taken on the staff at different points.

**Electronic digital levels:** The level which eliminates the need to read the staff and record readings, modelDL100digital level,Sokkia's SDL30,TopconDL500series level are available.

**:Concept of line of collimation:** It is an imaginary line passing through the intersection of the cross hairs at the diaphragm and the optical Centre of the object glass and its continuation. It is also known as line of sight.

**Axis of the telescope:** This is an imaginary line passing through the optical center of the object glass and the optical Centre of the eye piece.

**Axis of the bubble tube:** It is an imaginary line tangential to the longitudinal curve of the bubble tube at its midpoint.

**:Levelling Staff, types features and use:** A level staff is a graduated rod of rectangular section. It is usually made of teak wood. It may also be fiber glass or metal. Two types of rod are:-

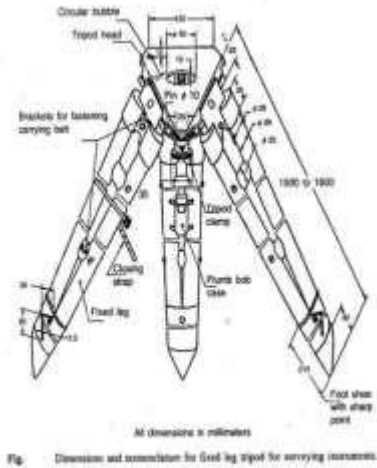
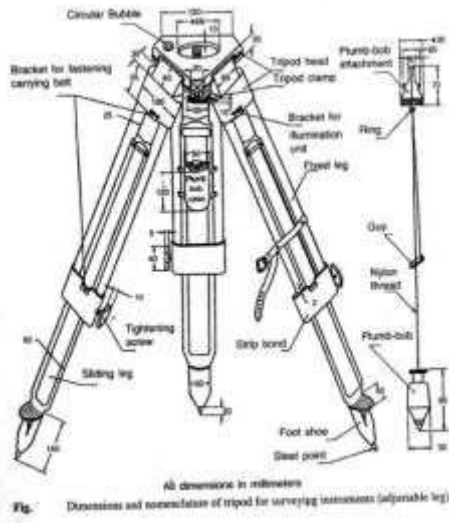

Fig.1.5a

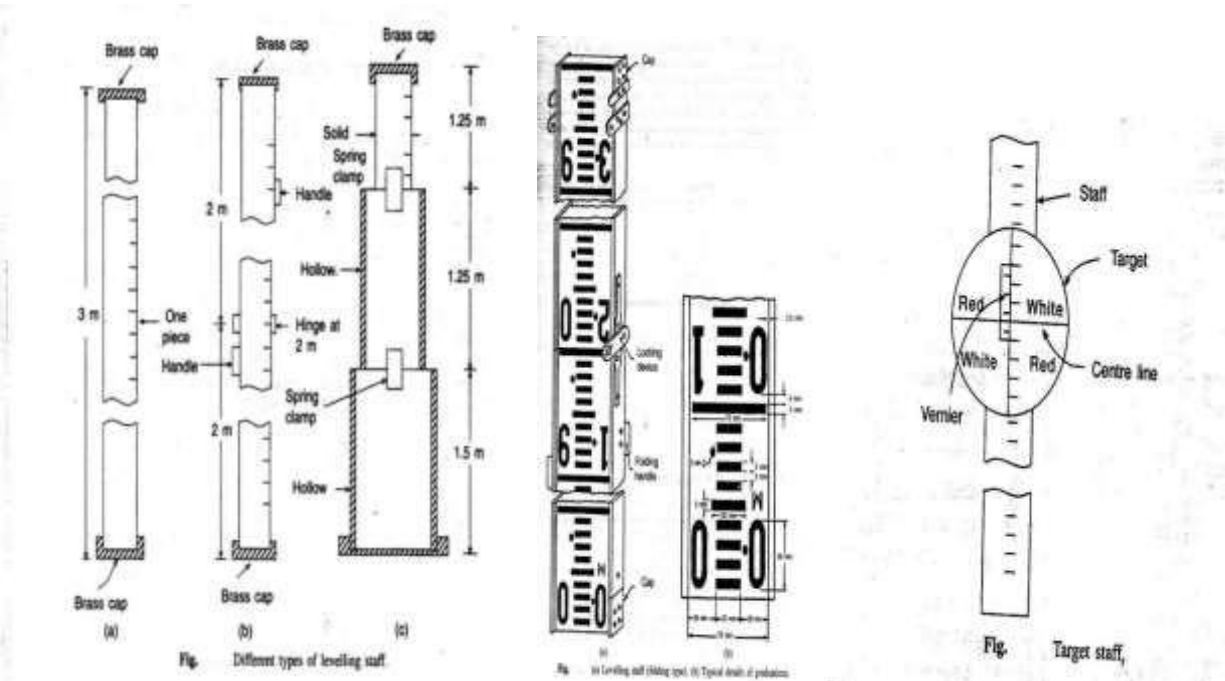

Fig.1.5b

1) Self-reading which can be read by the instrument operator with sighting through the telescope and noting the apparent intersection of the cross wires on the rod. This is the most

commontype.

2) The target rods having a movable target that is set by a rod person at the position indicated by signals from the instrument-man.

A leveling staff can be of

(a) Solid i.e. of one piece

(b) Folding when it can be folded to smaller length

(c) Telescopic, when the staff can be shortened by putting one piece inside another. Solid staff being of one piece gives more accurate reading. Folding staff is light and convenient to handle. As per IS-1779-1961, the width and thickness of the staff are 75mm and 18mm respectively. The staff can be folded to 2m length. To ensure the verticality the staff has a circular bubble of 25mm sensitivity. Each meter is divided into 200 sub-divisions, the thickness of the graduations being 5mm. In telescopic staff the topmost part is solid and the other two parts are hollow. The two top pieces when pulled up are kept in position by brass flat spring clamps at the back of each piece fixed at its lower end. While using the telescope staff care should be taken to ensure that the three parts are fully extended. The telescopic staff are is not as accurate as a folding staff because of slippage between the parts.

Target staff has sliding target equipped with vernier. It is used for long distance, when it becomes difficult to take staff readings directly. The target is a small metal piece of circular or oval shape about 125mm diameter. It is painted red and white in alternate quadrants. For taking reading the level man directs the staff man to raise or lower the target till it is bisected by the line of sight. The staff holder then clamps the target and take the reading.

### **: Temporary adjustment of level, taking reading with level:**

**1. Setting up:** Initially the tripod is set up at a convenient height and the instrument is approximately leveled. Some instruments are provided with a small circular bubble on the tribrach to check the approximate levelling. At this stage the leveling screw should be at the middle of its run.

**2. Levelling up:** The instrument is then accurately leveled with the help of leveling screws or foot screws. For instruments with three foot screws the following steps are to be followed.

a) Turn the telescope so that the level tube is parallel to the line joining any two leveling screws as shown in Fig.

b) Bring the bubble to the Centre of its run by turning the two leveling screws either both inwards or outwards.

c) Turn the telescope through 90°, so that the level tube is over the third screw or on the line perpendicular to the line joining screws 1 and 2. Bring the bubble to the Centre of its run by the

third foot screw only rotating either clockwise or anticlockwise.

d) Repeat the process till the bubble is accurately centred in both these conditions.

e) Now turn the telescope through  $180^\circ$  so that it again parallel to leveling screws 1 and 2. If the bubble still remains central, the adjustment is all right. If not, the level should be checked for permanent adjustments.

**3. Focussing:** This is done in two steps. First step is focusing the eye piece. This is done by turning the eye piece either in or out until the crosshairs are sharp and distinct. This will vary from person to person as it depends on the vision of the observer. The next step is focusing the objective. This is done by means of the focusing screw where by the image of the staff is brought to the plane of the cross hairs. This is checked by moving the eye up and down when reading the crosshair does not change with the movement of the eye as the image and the cross hair both move together.

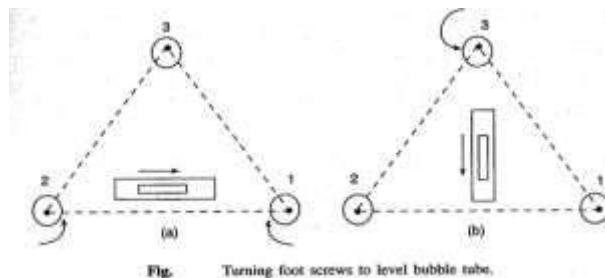

Fig.1.6

### : Concept of Bench Mark, BS, IS, FS, CP, HI:

**1. Station:** This is a point where a leveling staff is held for taking observations with a level.

**2. Height of the Instrument (HI):** It means elevation of the line of sight or line of collimation with respect to the datum.

**3. Back Sight (BS):** It is the first reading taken at a station of known elevation after setting up of the instrument. This reading gives the height of Instrument (elevation of line of collimation),

Elevation of line of collimation = Known elevation + backsight

**4. Intermediate Sight (IS):** These are readings taken between the 1<sup>st</sup> and last reading before shifting the instrument to a new station.

**5. Fore Sight (FS):** This is the last reading taken before shifting an instrument to a new station.

**6. Turning Point or Change Point:** For leveling over a long distance, the instrument has to be shifted a number of times. Turning point or change point connects one set of instrument readings with the next set of readings with the changed position of the Instrument. A staff is held on the turning point and a foresight is taken before shifting the instrument. From the next position of the instrument another reading is taken at the turning point keeping the staff undisturbed, which is known as backsight.

**7. Reduced Level (RL):** Reduced level of a point is its height relative to the datum. The Level is

calculated or reduced with respect to datum.



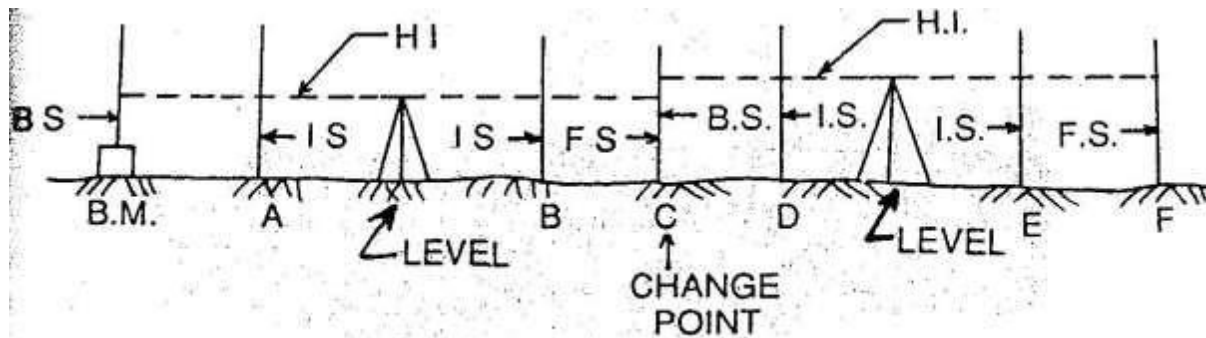

Fig.

Fig.1.7

**: Principles of levelling:**

a) **Direct or simple levelling:** In levelling it is desired to find out the difference in level between two points. Then if the elevation of one point is known, the elevation of other point can be easily found out. In fig. the instrument is placed at C roughly midway between two points A and B. the staff readings are shown in figure. From the figure the R.L of B can be derived as  $100.50 + 1.51 - 0.57 = 101.44$ mm. From the reading it can also be observed that, if the second reading is smaller than the first reading, it means that the second point is at higher level than that the first.

b) **Trigonometrically levelling:** In trigonometrically leveling the difference in elevation is determined indirectly from horizontal distance and the vertical angle. It is used mainly to determine elevations of inaccessible points such as mountain peaks, top of towers etc. as shown in fig.

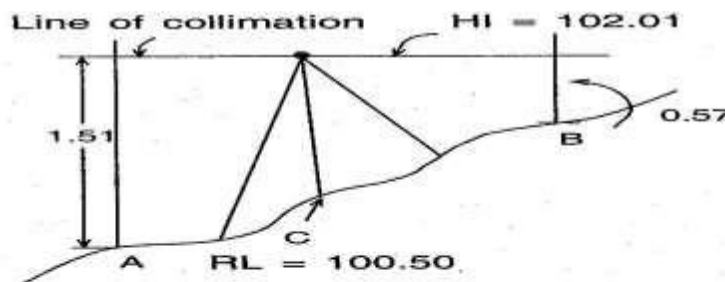

Fig. Direct levelling.

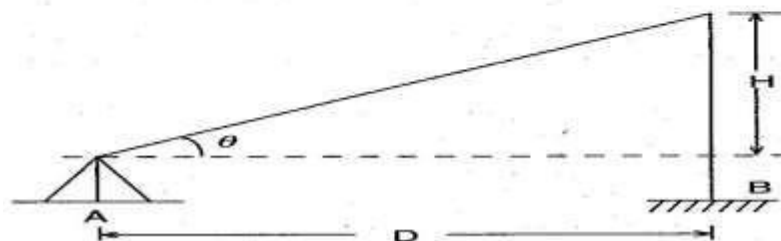

Fig. Trigonometrical levelling.

Fig.1.8

c) **Differential leveling:** This type of leveling is adopted when (i) the points are at a great distance apart, (ii) the difference in elevation between the points is large, (iii) there are obstacles between the points. This method is also known as compound levelling. In this method the level is set up at several suitable positions and staff readings are taken at all of these.

**:Field Data entry: Level book**

**A) Height of collimation or Height of Instrument method:**

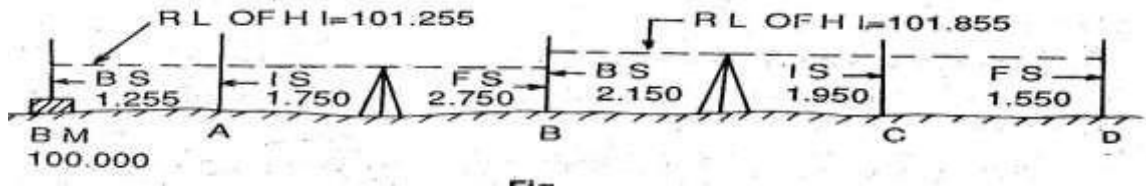

**Fig:1.9**

The reduced level of the line of collimation is said to be the height of instrument. In this system, the height of the line of collimation is found by adding the backsight reading to RL of the BM on which the BS is taken. Then the RL of the intermediate points and the change point are obtained by subtracting the respective staff readings from the height of Instrument (HI). The level is then shifted for the next set up and again the height of the line of collimation is obtained by adding the back sight reading to the RL of the change point (which is calculated in the first setup). So the ht. of instrument is different in different set ups of the level. Two adjacent places of collimation. Two adjacent planes of collimation are correlated at the change point by an FS reading from one setting and a BS reading from the next setting. The RLs of unknown points are to be found out by deducting the staff readings from the RL of the height of instrument. Referring to Fig.

a) RL of HI in 1<sup>st</sup> setting =  $100.00 + 1.255 = 101.255$ , RL of A =  $101.255 - 1.750 = 99.505$ , RL of B =  $101.255 - 2.150 = 99.105$ , (b) RL of HI in 2<sup>nd</sup> setting =  $99.105 + 2.750 = 101.855$ , RL of C =  $101.855 - 1.950 = 99.905$ , RL of D =  $101.855 - 1.550 = 100.305$  and so on., arithmetic check:  $\Sigma BS - \Sigma FS = \text{Last RL} - 1^{\text{st}} \text{RL}$ . The difference between the sum of backsights and that of foresights must be equal to the difference between the last RL and the first RL. This check verifies the calculation of the RL of the HI and that of the change point. There is no check on the RLs of the intermediate points.

**B) The Rise and Fall method:** In this method, the difference in level between two consecutive points is determined by comparing each forward staff reading with the staff reading at the immediately preceding point. If the forward staff reading is smaller than the immediately preceding staff reading, a rise is said to have occurred. The rise is added to the RL of the preceding point to get the RL of the forward point. If the forward staff reading is greater than the immediately preceding staff reading; it means there has been a fall. The fall is subtracted from the RL of the preceding point to get the RL of the forward point. Refer. to Fig.

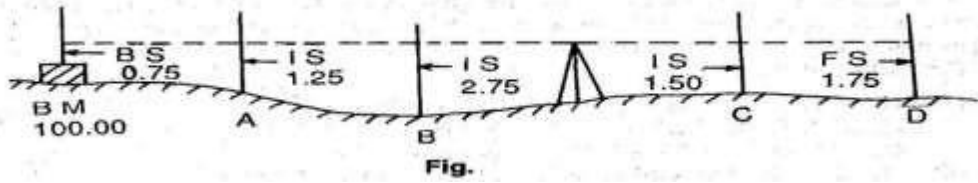

Fig.1.9

Point A(with respect to BM)= $0.75-1.25=-0.50$ (Fall), Point B(with respect to A)= $1.25-2.75=-1.50$ (Fall),

Point C(with respect to B)= $2.75-1.50=+1.25$ (Rise),Point D(with respect to C)= $1.50-1.75=-0.25$ (fall)

RL of BM=100.00,RL of A=100.00-0.50=99.50, RL of B=99.50-1.50=98.50, RL of C=98.00+1.25=99.25, RL of D=99.25-0.25=99.00

Arithmetic Check: $\Sigma BS - \Sigma FS = \Sigma Rise - \Sigma Fall = Last RL - 1st RL$

In this method,the difference between the sum of BS's and that ofFS's,the difference between the sum of rises and that of falls and the difference between the Last RL, and the first RL must be equal.

*Note:The arithmetical check is ment only for the accuracy of calculation to be verified.It does not verify the accuracy of field work.There is a complete check on the RLs of the intermediate points in the rise and fallsystem.*

### Comparison of the two systems:

Sl.No.	Collimation System	Rise and fall system
1.	It is rapid as it involves few calculation	It is labourious,involving several calculations
2.	There is no check on the RL of intermediate points	There is a check on the RL of intermediate points
3.	Errors in immediate RLs cannot be detected	Errors in immediate RLs can be detected as all the points are correlated
4.	There are two checks on the accuracy of RL calculation	There are three checks on the accuracy of RL calculation
5.	This system is suitable for longitudinal levelling where thereare a number of intermediate sights.	This system is suitable for fly levelling where there are no intermediate sights.

### Points to be remembered while entering the level Book:

1.The first reading of any support is entered in the BS column,the last reading in the FS column

and the other readings in the IS column.

2. A page always starts with BS and finishes with an FS reading.
3. If a page finishes with an IS reading, the reading is entered in the IS and FS columns on that page and brought forward to the next page by entering it in the BS and IS columns.
4. The FS and BS of any change point are entered in the same horizontal line.
5. The RL of the line of collimation is entered in the same horizontal line in which the corresponding are entered.
6. Bench Mark (BM) and change point (CP) should be clearly described in the remark column.

**Example:** The following consecutive readings were taken with a dumpy level along a chain line at a common interval of 15m. The first reading was at a chainage of 165m, where RL is 98.085. The instrument was shifted after the fourth and ninth readings: 3.50, 2.245, 1.125, 0.860, 3.125, 2.760, 1.835, 1.470, 1.965, 1.225, 2.390 and 3.035

Mark rules on a page of your note book in the form of a level book page and enter on it the above readings and find the RL of all the points by: (1) The line of Collimation method, (2) The Rise and fall method apply the usual checks.

(1) The line of Collimation method:

Station point	Chainage	BS	IS	FS	RL of Line of collimation (HI)	RL	Remarks
1	165	3.150	xxxx	xxxx	101.235	98.085	
2	180	xxxx	2.245	xxxx	xxxx	98.990	
3	195	xxxx	1.125	xxxx	xxxx	100.110	
4	210	3.125	xxxx	0.860	103.500	100.375	Change Point
5	225	xxxx	2.760	xxxx	xxxx	100.740	
6	240	xxxx	1.835	xxxx	xxxx	101.665	
7	255	xxxx	1.470	xxxx	xxxx	102.030	
8	270	1.225	xxxx	1.965	102.760	101.535	Change Point
9	285	xxxx	2.390	xxxx	xxxx	100.370	
10	300	xxxx	xxxx	3.035	xxxx	99.725	
<b>TOTAL=</b>		<b>7.500</b>	xxxx	<b>5.860</b>	xxxx	xxxx	

Arithmetic Check:  $\Sigma BS - \Sigma FS = \text{Last RL} - 1^{\text{st}} \text{RL}$ ,  $(7.500 - 5.860) = +1.640$ ,  $(99.725 - 99.085) = +1.640$

2) The Rise and fall method:

Station point	Chainage	BS	IS	FS	Rise(+)	Fall(-)	RL	Remarks
1	165	3.150	xxxx	xxxx	xxxx	xxxx	98.085	

2	180	xxxx	2.245	xxxx	0.905	xxxx	98.990	
---	-----	------	-------	------	-------	------	--------	--

3	195	xxxx	1.125	xxxx	1.120	xxxx	100.110	
4	210	3.125	xxxx	0.860	0.265	xxxx	100.375	ChangePoint
5	225	xxxx	2.760	xxxx	0.365	xxxx	100.740	
6	240	xxxx	1.835	xxxx	0.925	xxxx	101.665	
7	255	xxxx	1.470	xxxx	0.365	xxxx	102.030	
8	270	1.225	xxxx	1.965	xxxx	0.495	101.535	ChangePoint
9	285	xxxx	2.390	xxxx	xxxx	1.165	100.370	
10	300	xxxx	xxxx	3.035	xxxx	0.645	99.725	
<b>TOTAL=</b>		<b>7.500</b>	<b>xxxx</b>	<b>5.860</b>	<b>3.945</b>	<b>2.305</b>	<b>xxxx</b>	

$\Sigma BS - \Sigma FS = 7.500 - 5.860 = +1.640$ , Last RL - 1<sup>st</sup> RL = (99.725 - 98.085) = +1.640,

$\Sigma Rise - \Sigma Fall = 3.945 - 2.305 = +1.640$

**Exercise No.1:** The following figures are staff readings taken in order on a particular scheme, the backsights being 0.813, 2.170, 2.908, 2.630, 3.133, 3.752, 3.277, 1.899, 2.390, 2.810, 1.542, 1.274, 0.643. The first reading was taken on a bench mark 39.563. Enter the readings in level book form, check the entries, and find the reduced level of the last point. Comment on your completed reduction.

**Exercise No.2:** A page of an old level book had been damaged by white ants and the readings marked X are missing. Find the missing readings with the help of available readings and apply arithmetical checks.

Distance in m	BS	IS	FS	RL of Line of collimation (HI)	RL	Remarks
	X			X	209.510	B.M
0		1.675			X	
30		X			210.425	
60		3.355			209.080	
X	0.840		X	209.520	X	Change Point
120		X			208.275	
150		X			210.635	Underside of bridge girder
X	X		2.630	X	X	X
210		X			206.040	
240		1.920			205.895	
270			X		205.690	

### :Different types of levelling, uses and methods:

1) **Differential or Fly Levelling:** It is carried out when the difference in elevation between two points that are far apart is to be determined. Here there is no need to determine the RLs of the intermediate points. This method is adopted when one wants to establish a benchmark near the



site of leveling work. Essentially, Backsights and foresights are taken to reach a point B starting from appoint A This relates the R.L of point B with the known RL of point A. (Ref: Fig.)

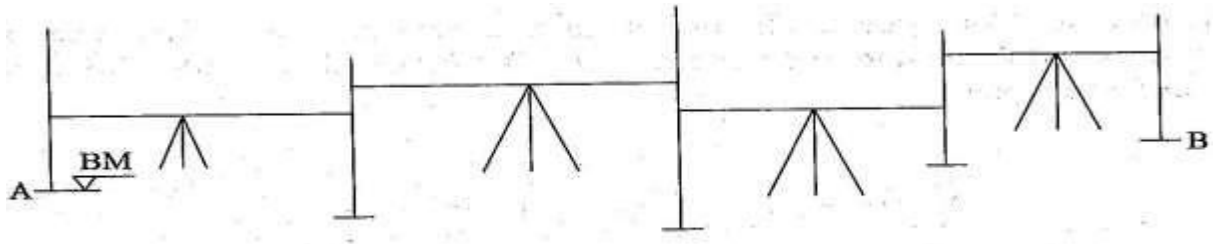

**Fig** Differential or fly levelling

Fig.1.10

**Example:**

Stationpoint	BS	IS	FS	Rise(+)	Fall(-)	RL	Remarks
BM	0.955	xxxx		xxxx	xxxx	250.550	on BM No.1
	1.250	xxxx	2.150		1.195	249.355	
	0.785	xxxx	1.760		0.510	248.845	
	1.535	xxxx	2.055		1.270	247.575	ChangePoint
	1.260	xxxx	0.835	0.700	xxxx	248.275	
	0.675	xxxx	0.955	0.305	xxxx	248.580	
	1.275	xxxx	1.505		0.830	247.750	
	1.675	xxxx	2.050	xxxx	0.775	246.975	ChangePoint
	0.450	xxxx	2.160	xxxx	0.505	246.470	
A	xxxx	xxxx	1.005	xxxx	0.555	245.915	Starting point of roadproject
<b>TOTAL=</b>	<b>9.840</b>	<b>xxxx</b>	<b>14.475</b>	<b>1.005</b>	<b>5.640</b>	<b>xxxx</b>	

$$\Sigma BS - \Sigma FS = 9.840 - 14.475 = -4.635, \text{ Last RL} - 1^{\text{st}} \text{ RL} = (245.915 - 250.550) = -4.635,$$

$$\Sigma \text{ Rise} - \Sigma \text{ Fall} = 1.005 - 5.640 = -4.635$$

**2) Check Levelling:** It is the operation done to check the leveling work done. A simple method is to run a series of levels as in fly leveling up to the starting point of the survey at the end of the day. This will check the accuracy of the leveling work.

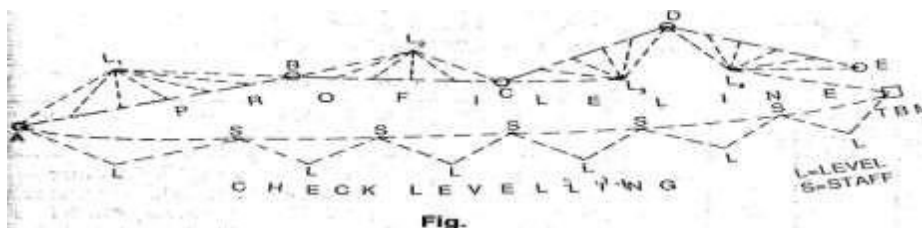
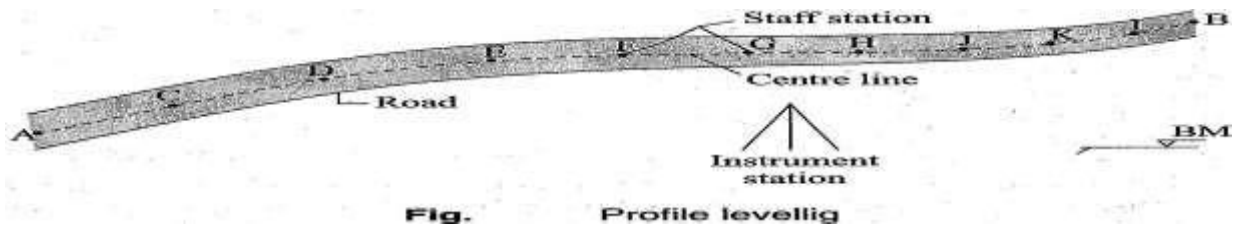

Fig:1.10

3) **Profile Levelling:** Profile leveling or sectioning is leveling done across a line, e.g., along the Centre line of the road, to get a sketch of the profile. Essentially the staff stations have to be ranged to be along a line. Readings are taken on the staff held along this line. When the levels are plotted along the distances in a line, we get a profile of the ground showing the elevations of the points. (Ref. Fig.)



**Fig:1.10**

4) **Cross sectioning:** It involves taking levels across a line, e.g. the Centre line of a road, or a railway line. Depending upon the width of road, a number of staff stations are fixed across the centreline. This again gives a profile perpendicular to the longitudinal line and is useful in calculating the volume, etc.

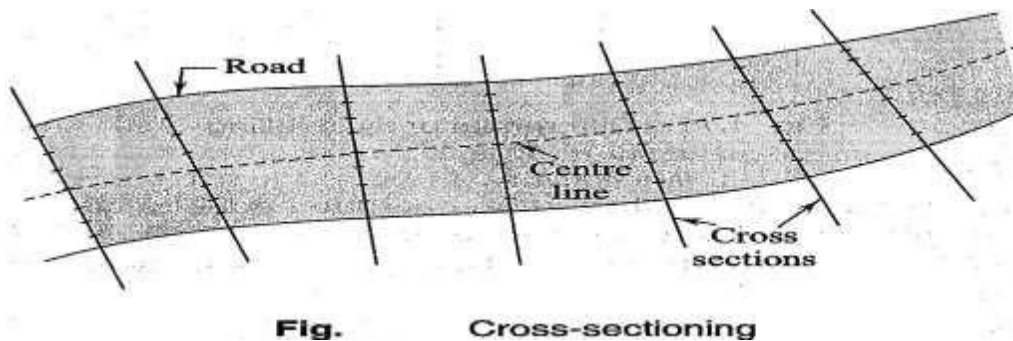

**Fig:1.10**

5) **Reciprocal Levelling:** Reciprocal levelling is done when the distances are long and it is not possible to balance the lengths of the line of sights. This happens, e.g., in the case of points lying on either side of a river, when it is not possible to maintain the level between the two points. This process eliminates many errors due to maladjustment of the instrument and those due to curvature and refraction.

**:Plotting of profiles:a) Longitudinal sections:**

For plotting normally the Horizontal scale of 1:1000 or 1:2000 and vertical scale which is of either 1:100 or 1:200 is followed. A horizontal line is drawn as the datum line. The changes are marked along this line according to the horizontal scale. Then the ordinates (perpendicular

lines)are drawn at each of the chainagepoints. The RL of the datum line is assumed in such a

way that the ground surface can be shown above the datum. Now the vertical distances (RL of GL-RL of datum) are plotted along the ordinates according to the vertical scale. The plotted points are joined to obtain the outline of the ground surface (as shown in fig.). The formation line are drawn in Red ink.

a) **Cross sections:** The cross sections are drawn/plotted in the same way as of longitudinal sections, but the Horizontal and vertical scales are slightly different (Horiz. 1:400, Vert. 1:100 are normally followed)

**Example of profile levelling:**

Station	Chainage	Bearing		Readings			Rise (+)	Fall (-)	RL	Remark
		FB	BB	BS	IS	FS				
A	0	AB = 80°30'		1.525					245.915	Starting point of project C/S-1
	20				2.150			0.625	245.290	
	40				2.650			0.500	244.790	C/S-2
	60			0.950		0.850	1.800		246.590	CP
	80				2.055			1.105	245.485	C/S-3
	100				1.965		0.090		245.575	
B	115	BC = 120°30'	AB = 260°30'	1.305		1.255	0.710		246.285	CP
	120				1.850			0.545	245.740	C/S-4
	140				2.360			0.510	245.230	
	160			1.055		0.755	1.605		246.835	CP C/S-5
	180				1.860			0.805	246.030	
	200				2.950			1.090	244.940	
C	220	CD = 30°15'	BC = 300°30'	0.890		1.155	1.795		246.735	CP C/S-6
	240				1.755			0.865	245.870	
	260				2.680			0.925	244.945	
D	280	DE = 140°0'	CD = 210°15'	1.350		1.270	1.410		246.355	C/S-7
	300				2.105			0.755	245.600	
	320				2.655			0.550	245.050	C/S-8
	340				3.250			0.595	244.455	
E	360		DE = 320°0'		1.760		1.490		245.945	C/S-9
TBM						0.715	1.045		246.990	TBM kept on top of well

**Cross-section 1 at chainage 0**

Distances			BS	IS	FS	Rise	Fall	RL	Remark
Left	Centre	Right							
	0		0.760					245.915	Centre at chainage 0. RL is taken from longitudinal section
		5		1.875			1.115	244.800	
		10		2.360			0.485	244.315	
		15		0.985		1.375		245.690	
		20		0.375		0.610		246.300	
5				2.015			1.640	244.660	
10				1.550		0.465		245.125	
15				0.790		0.760		245.885	
20					1.525		0.735	245.150	
Summation =			0.760		1.525	3.210	3.975		

**Cross-section 2 at chainage 40**

Distances			BS	IS	FS	Rise	Fall	RL	Remark
Left	Centre	Right							
	0		1.035					244.790	Centre at chainage 40. RL is taken from longitudinal section
		5		2.620			1.585	243.205	
		10		3.155			0.535	242.670	
		15		1.935		1.220		243.890	
		20		0.760		1.175		245.065	
5				1.875			1.115	243.950	
10				2.620		0.770	0.745	243.205	
15				1.850		0.875		243.975	
20					0.975			244.850	
Total =			1.035		0.975	4.040	3.980		
Check =			$\Sigma BS - \Sigma FS = 1.035 - 0.975 = + 0.060$			$\Sigma Rise - \Sigma fall = 4.040 - 3.980 = + 0.060$		$= 244.850 - 244.790 = + 0.060$	

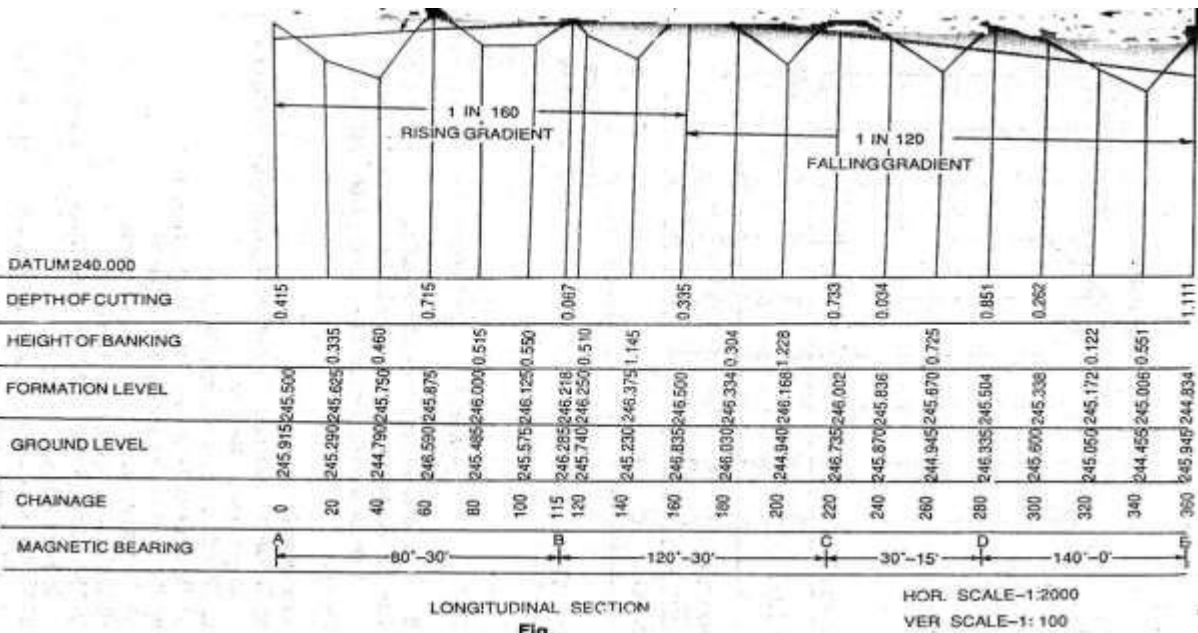

Fig.1.11

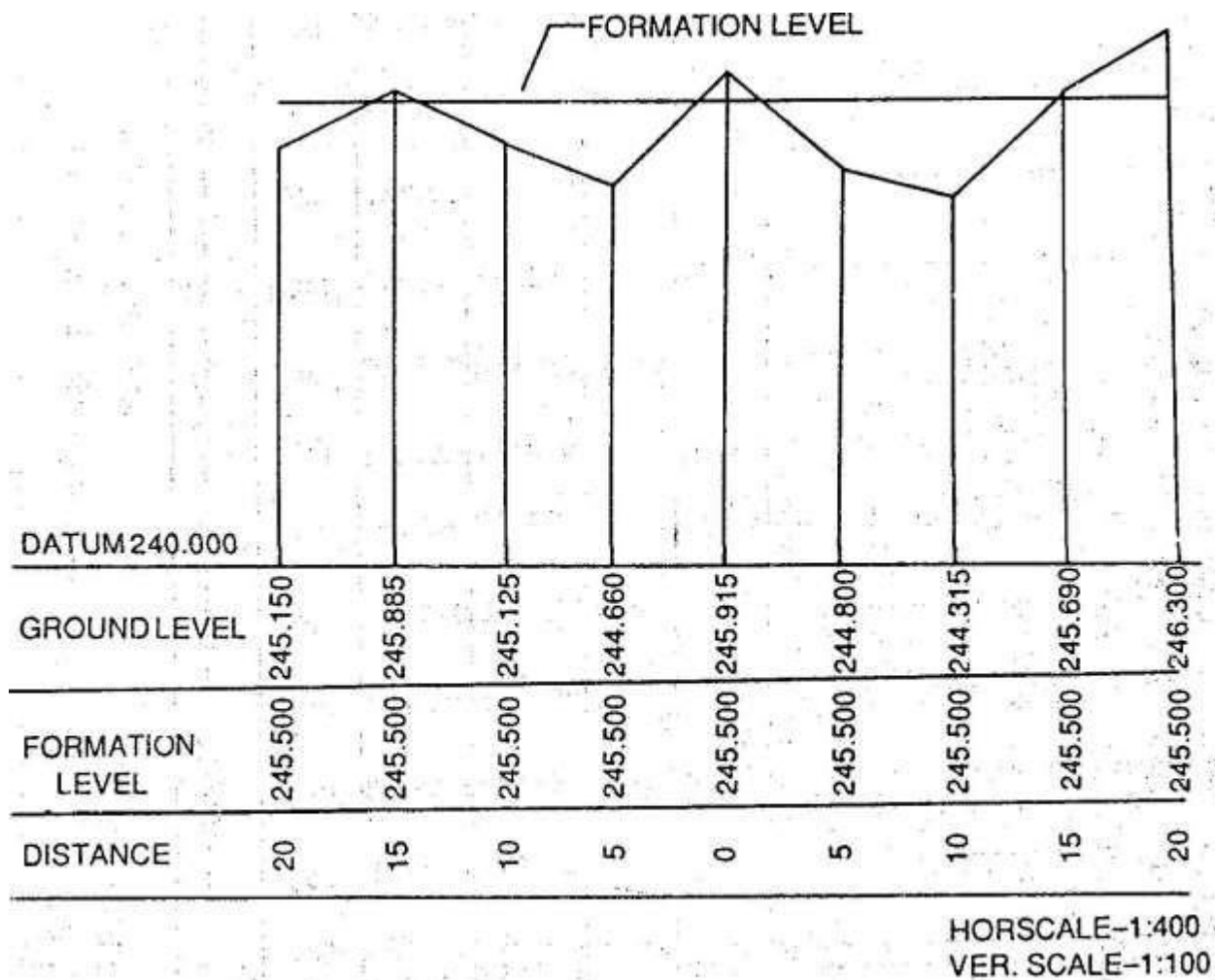

Fig.

Fig:1.11

**Efects of Curvature andrefraction:**

Leveling instruments provide horizontal line of sight and as a result curvature error occurs. In addition due to refraction in earth's atmosphere the ray gets bent towards the earth introducing refraction errors. Fig. illustrates these errors. Neglecting small instrument Height SA, OA can be taken as the radius of earth, From Geometry of a circle,  $AB(2R+AB)=d^2$ , as AB is very small compared to diameter of the earth  $AB \cdot 2R = d^2$ ,  $AB = d^2/2R$ , The dia. Of earth is taken as 12734KM, Hence curvature correction:  $AB = d^2/12734 \text{ Km} = 0.078 d^2 \text{ m}$ , d, is expressed in Km. The radius of ray IC is bent due to refraction is taken as seven times the radius of earth. The refraction correction is taken as  $1/7^{\text{th}}$  of the curvature correction. Refraction correction reduces the curvature

correction and hence combined correction is  $\frac{6}{7}$ th of  $0.078d^2m$ , i.e.  $0.067d^2$  and  $d$  is expressed in Km. The correction is subtractive from staff reading.

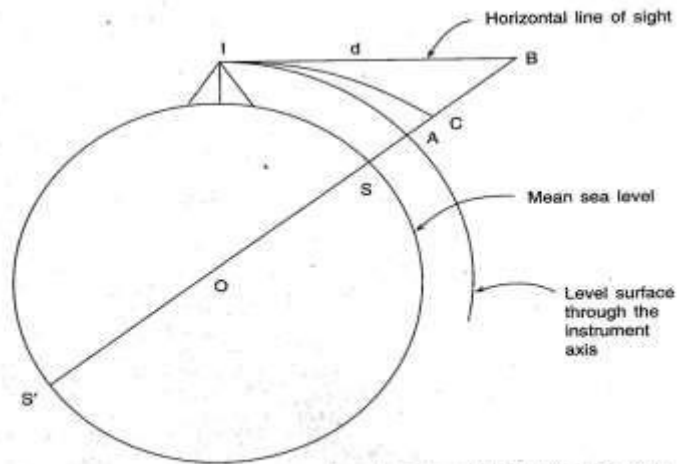

Fig. Curvature and refraction correction:  $I$  = instrument station;  $S$  = staff station;  $AB$  = curvature error;  $BC$  = error due to refraction;  $AC$  = combined error due to curvature and refraction;  $SB$  = staff normal to earth's surface;  $IB = d$ , distance of the staff from the instrument.

Fig.1.12

**Example:** Determine the distance for which the combined correction is 5mm.

$$\text{Correction in m} = 0.067d^2 \text{ where } d \text{ is in Km, } d^2 = 0.005 / 0.067, d = \sqrt{0.005 \div 0.067} \\ = 0.273 \text{ Km} = 273 \text{ m}$$

**Exercise:** A sailor standing on the deck of a ship just sees the top of a light house. The top of the light house is 30m above sea level and the height of sailor's eye is 5m above sea level. Find the distance of the sailor from the light house.

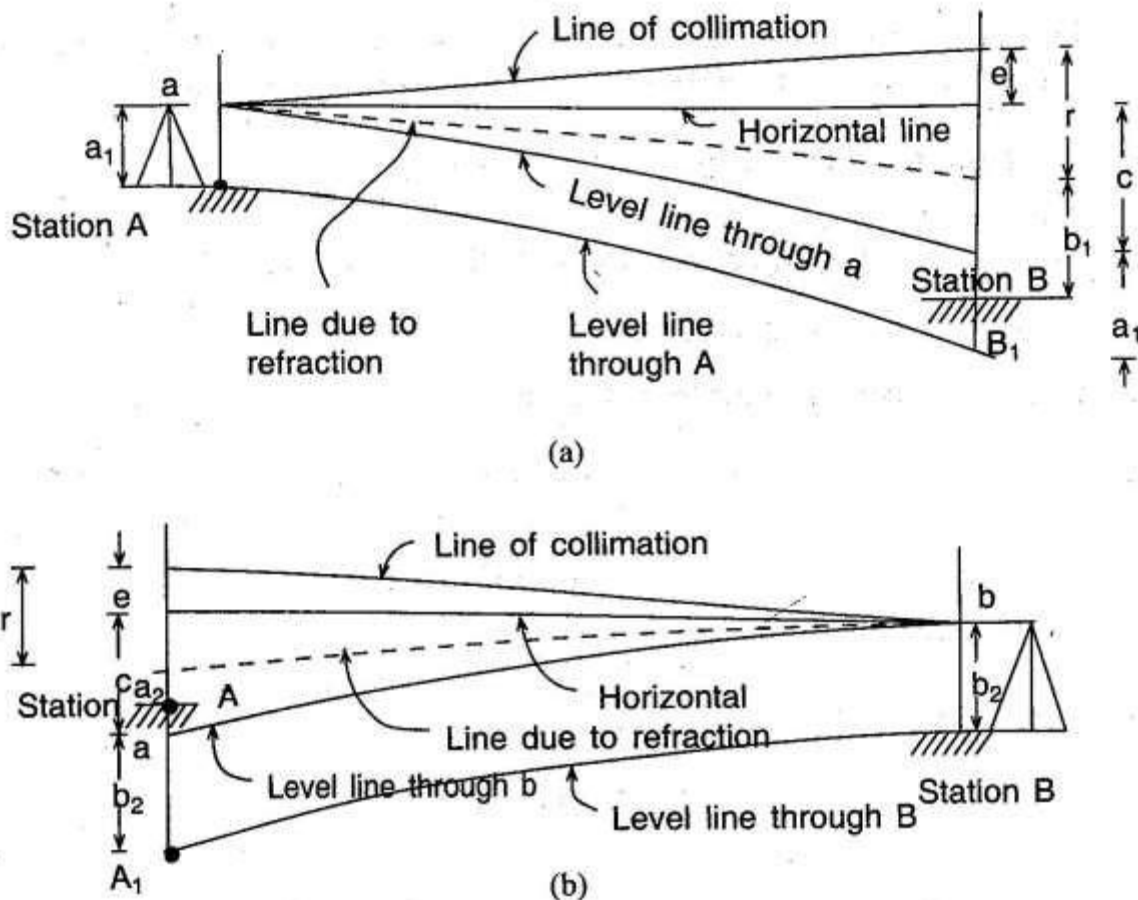

Fig:1.13

### Reciprocallevelling:

While crossing a river or ravine it is not possible to put the level midway so that the back sight and foresight are equal. Sight distance ,however, is long and errors due ti (i)collimation,(ii)curvature and refraction are likely to occur. To avoid these errors two observations are made.As shown in fig. instrument is placed near station A and observations are made. On staffs at A and B.Similarly instrument is placed near B and staff readings are taken on B and A.

From 1<sup>st</sup> set of reading: difference in level= $d=BB_1=a_1+c+e-r-b_1=(a_1.b_1)+(c-r)+e$

From 2<sup>nd</sup> set of reading: Difference in level = $d=AA_1=-(b_2+c+e-r-a_2)=(a_2.b_2)-(c-r)-e$ (-sign as difference is measured at A instead of at B),By adding: $2d= (a_1-b_1)+(a_2-b_2)$ ,or,  $d=1/2[(a_1-b_1)+(a_2-b_2)]$ ,

Subtracting,  $2(c-r)+e=[(a_2-b_2)-(a_1-b_1)]$ ,or $(c-r)+e =1/2[(a_2-b_2)-(a_1-b_1)]$ ,C=curvature error,r=refraction error,e=error due tocollimation.



**Example:** The results of reciprocal leveling between station A and B 250m apart on opposite sides of a wide river were as follows.

Level at A ----- ht. of eyepiece(m) 1.399 ----- staff reading 2.518 on B

Level at B ----- ht. of eyepiece(m) 1.332 ----- staff reading 0.524 on A

Find the true difference of level between the stations and the error due to imperfect adjustment of the instrument assuming the mean radius of earth 6365 Km.

**Solution:** Since the staff is very close to A and B in 1<sup>st</sup> and 2<sup>nd</sup> set up respectively, the height of the eyepiece is taken as the staff reading. True difference of level =  $\frac{1}{2}[(a_1 - b_1) + (a_2 - b_2)] = \frac{1}{2}[(1.399 - 2.518) + (0.524 - 1.332)] = -0.964\text{m}$ , indicating that A is at a lower level than B.

Total error =  $\frac{1}{2}[(a_2 - b_2) - (a_1 - b_1)] = \frac{1}{2}[(-0.808) - (-1.119)] = +0.156\text{m}$ , Error due to curvature and refraction =  $L^2/2R[1 - 2m] = 0.00422\text{m}$ , Error due to collimation =  $+0.156 - 0.004 = +0.152$  in 250m, Hence error/100m =  $+0.06\text{m}$

**Precise leveling:** Precise levelling aims at establishing the RL of a point with highest precision. The objective of providing such high order of precision in the measurement is to establish a network of Bench marks. Precise leveling employs a precise level, a precise leveling staff and all possible corrections in order to attain accuracy of highest order in the instrument.

**Field Work:** 1) Back sights and fore sights are taken with the instrument equidistant from the staffs for elimination of collimation errors, error due to curvature and refraction. (2) More than one setting at the same instrument position will help in the reduction of error. (3) Reading in the staff are taken in three levels of stadia hairs.

**Difficulties in leveling:**

**1. When the staff is too near the staff:** if the staff is held very near the leveling instrument, the graduations of the staff are not visible. In such a case a piece of paper is moved up and down along the staff until the edge of the paper is bisected by the line of collimation. Then the reading is noted from the staff with the naked eye. Sometimes the reading is taken by looking through the object glass.

**2 Levelling across a large pond or lake:** As the water surface is level, all the points on it will have the same RL. Two pegs A and B are fixed on opposite banks of the lake or Pond. The tops of the pegs are just flush with the water surface. The level is set up at O<sub>1</sub> and the RL of A is determined by taking the FS on A. The RL of B is assumed to be equal to that of A. Now the level is shifted and set up at O<sub>2</sub>. Then by taking the BS on Peg B, leveling is continued (Ref: Fig.)

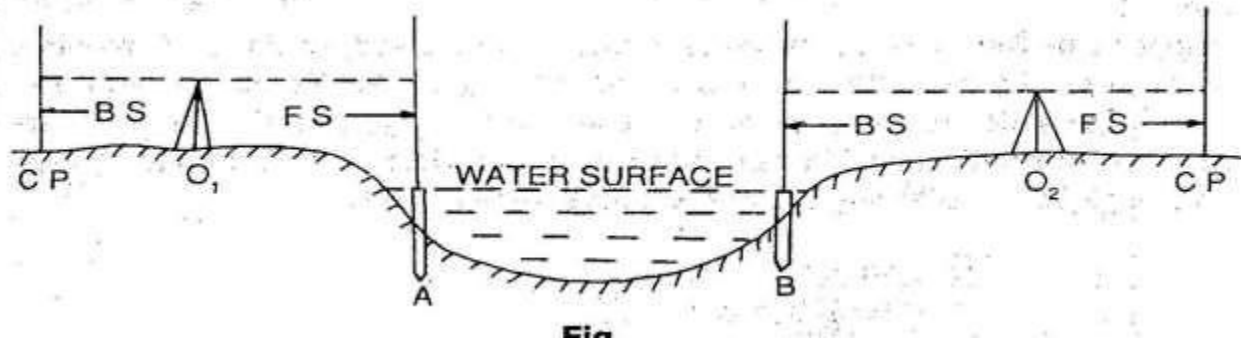

Fig:1.14

**3 Levelling across a River:** In case of a flowing water the surface cannot be considered to be level. The water levels on opposite edges will be different. In this case the method of Reciprocal leveling is followed.

**4 Levelling across a Solid wall:** When leveling is carried across a brick wall, two pegs A and B are driven on either side of the wall just touching it. The level is setup at  $O_1$  and a staff reading is taken on A. Let this reading is  $A_c$ . Then the height of the wall is measured by staff. Let the ht. be  $AE$ . The HI is found out by taking a BS on any BM or CP, Then  $RL\ of\ A = HI - A_c$ ,  $RL\ of\ E = RL\ of\ A + AE = RL\ of\ F$  (Same level). The level is shifted to some point  $O_2$ . The staff reading  $B_d$  is noted and the Ht. measured. Thus  $RL\ of\ B = RL\ of\ F - B_d$ ,  $HI\ at\ O_2 = RL\ of\ B + B_d$ , The leveling is then continued by working out the HI of the setting (Ref. Fig)

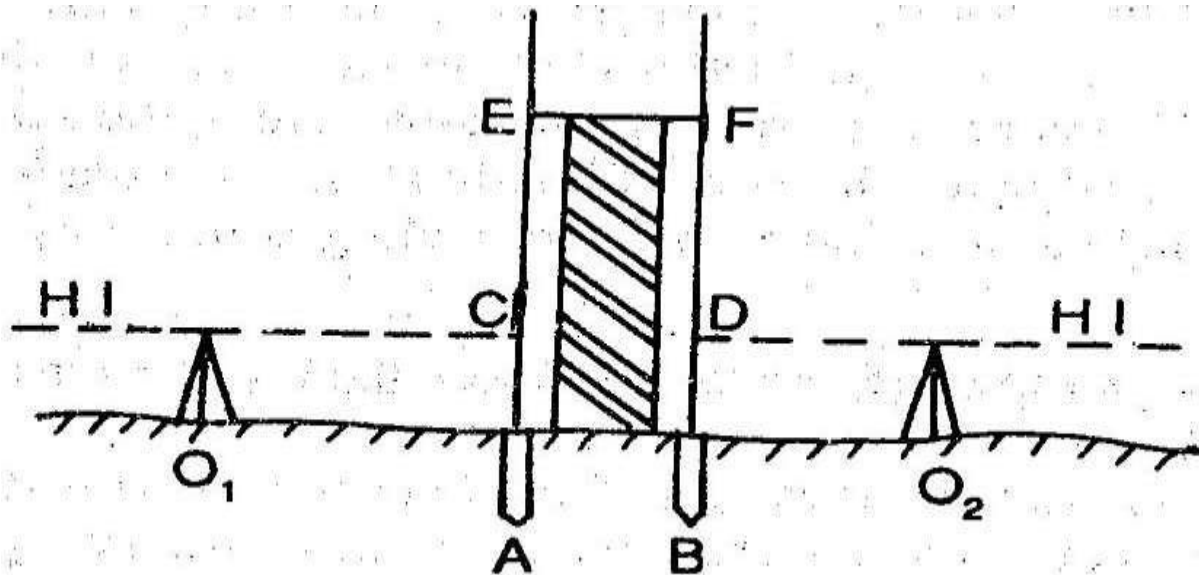
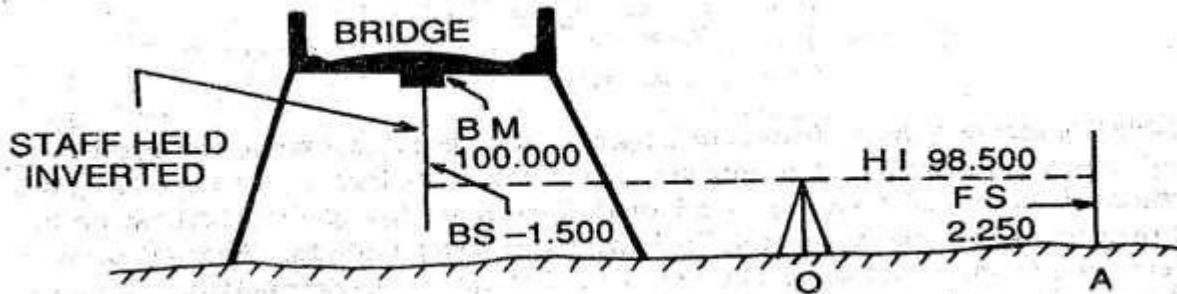

Fig.

Fig:1.14

**5. When the BM is above the Line of collimation:** This happens when the BM is at bottom of a bridge girder or on the bottom surface of a culvert. Suppose the BM exists on the bottom surface of a culvert and that is required to find out the RL of A. The level is set up at O and the staff is held inverted on the BM. The staff reading is taken and noted with a negative sign. The remark "staff held inverted" is to be entered in the appropriate column. Let the BS and FS readings be -1.500 and 2.250 respectively. Now,  $HI = 100.000 - 1.500 = 98.500$ ,  $RL \text{ of } A = 98.500 - 2.250 = 95.250$ .



**Fig**

Fig.1.14

**6. Levelling along a steep slope:** While leveling along a steep slope in a hilly area, it is very difficult to have equal BS and FS distances. In such cases the level should be set up along a Zig-zag path so that the BS and FS distances may be kept equal. Let AB be the direction of leveling.  $I_1, I_2, \dots$  are the positions of the level and  $S_1, S_2, S_3, \dots$  are the staff positions (Ref. Fig.). Levelling is continued in this manner and the RLs of the points are recalculated.

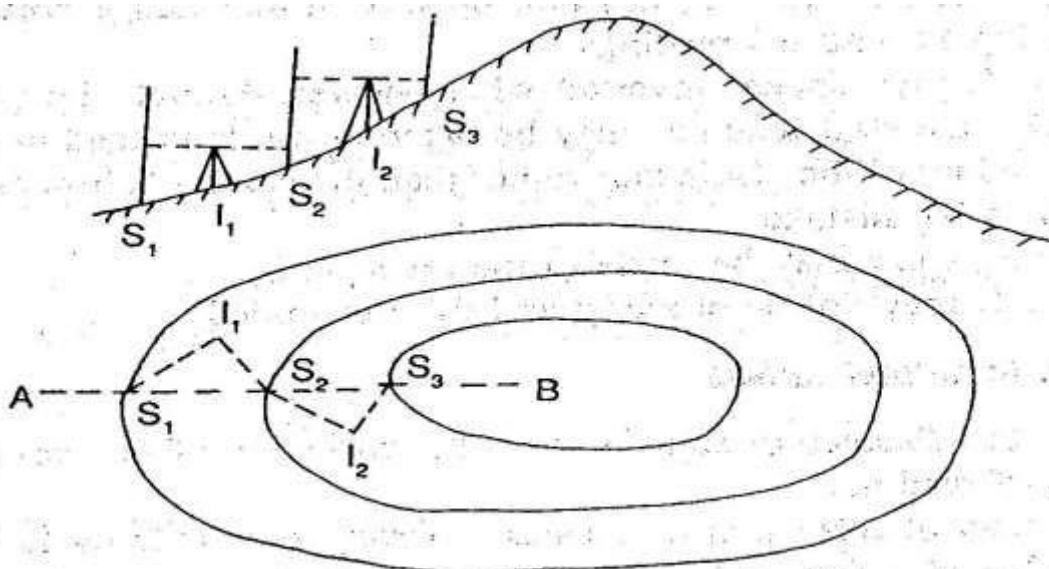

**Fig.**

Fig:1.14

**7. Levelling across arising ground or depression:** While levelling across high ground, the level should not be placed on top of this high ground, but on one side so that the line of collimation just passes through the apex. While leveling across a depression, the level should be set up on one side and not at the bottom of the depression. (Ref: Fig.)

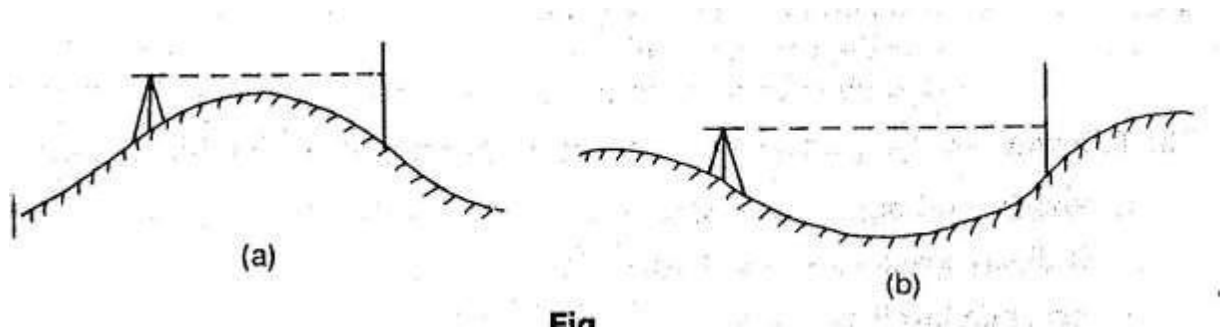

Fig:1.14

### Errors in levelling and precautions:

**1. Instrumental errors:** (a) The permanent adjustment of the instrument may not be perfect. That is the line of collimation may not be parallel to the axis of the bubble tube. (b) The internal arrangement of the focusing tube is not perfect. (c) The graduation of the leveling staff may not be perfect.

**2. Personal errors:** (a) The instrument may not be leveled perfectly. (b) The focusing of eye piece and object glass may not be perfect and the parallax may not be eliminated entirely. (c) The position of the staff may be displaced at the change point at the time of taking FS and BS readings. (d) The staff may appear inverted when viewed through the telescope. By mistake, the staff readings may be taken upwards instead of downwards. (e) The reading of the stadia hair rather than the central collimation hair may be taken by mistake. (f) A wrong entry may be made in the level book. (g) The staff may not be properly and fully extended.

**3. Errors due to natural Causes:** (a) When the distance of sight is too long, the curvature of the earth may effect the staff reading. (b) The effect of refraction may cause a wrong staff reading to be taken. (c) The effect of high winds and a shining Sun may result in a wrong staff reading.

### Permissible Errors in Levelling:

The precision of levelling is ascertained according to the error of closure. The permissible limit of closing error depends upon the nature of work for which the leveling is to be made. It is expressed as:  $E = C\sqrt{D}$ , Where,  $E$  = closing error in meter,  $C$  = the constant,  $D$  = distance in Km. The following are the permissible errors for different types of leveling:

1) Rough leveling- $E=\pm 0.100\sqrt{D}$ , (2) Ordinary leveling:  $-E=\pm 0.025\sqrt{D}$ , (3) Accurate Levelling:  $-E=\pm 0.012\sqrt{D}$ , (4) Precise Levelling:  $-E=\pm 0.006\sqrt{D}$

**Sensitiveness of bubble tube, determination of sensitiveness:**

The sensitivity of the level tube depends on the Radius of curvature( R) and usually expressed as  $\theta$  per unit division( $d$ ). This angle may vary from 1" to 2" in the case of precise level, up to 10" to 30" on engineer's level. This can be determined by in the field by observing the staff readings at a known distance from the level by changing the bubble position by means of a foot screw as shown in Fig.

$\tan\theta=S/l$ , Since  $\theta$  is very small,  $\tan\theta\approx n\theta$ ,  $n\theta_{rad}=S/l$ ,  $\theta_{rad}=S/nl$ ,  $\theta_{sec}=206265S/nl$ , Where  $S$ = diff. in staff reading a and b,  $n$ = no. of divisions the bubble is displaced between readings,  $l$ =distance of staff from instrument. If  $d$ =length of one division of the bubble tube then,  $d=R\theta_{rad}$ ,

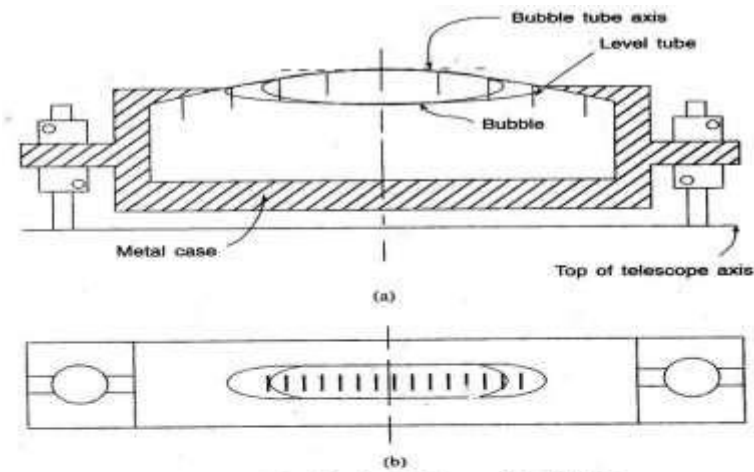

Fig. A bubble tube: (a) Cross section. (b) plan.

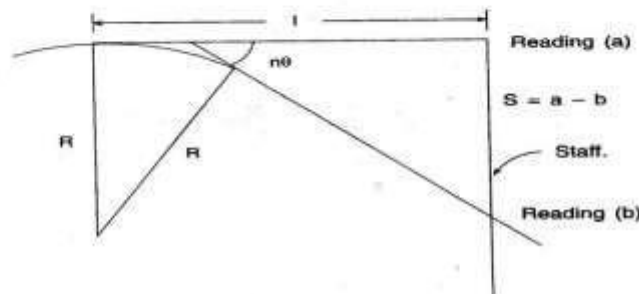

Fig. Sensitivity of bubble tube.

Fig:1.15

or  $R=d/\theta=ndl/S$ , A tube is said to be more sensitive, if the bubble moves by more divisions for a given change in the angle. The sensitivity of a bubble tube can be increased by:

- a) Increasing internal radius of the tube, (b) Increasing diameter of the tube, (c) Increasing the

length of the bubble, (d) decreasing the roughness of wall, (e) decreasing viscosity of the liquid. The

sensitivity of the bubble tube should tally with the accuracy achievable with other parts of the equipment. If the bubble is graduated from the centre than an accurate reading is possible by taking readings at the objective and eye piece ends (ref Fig.)

Let  $L$  = length of bubble =  $O_1 + E_1 = O_2 + E_2$ ,  $XX = \frac{(O_1 + E_1)}{2} - E_2$ ,  $YY = \frac{(O_2 + E_2)}{2} - O_2$ , Total movement =  $\frac{(O_1 - E_1)}{2} + \frac{(E_2 - O_2)}{2}$

Example: A three screw dumpy level, set up with the telescope parallel to two foot screws is sighted on a staff 100m away. The line of sight is depressed by manipulating the foot screws until the bubble on the telescope reads 4.1 at the object glass end and 14.4 at the eye piece end, these readings representing divisions from a zero at the centre of the bubble tube. The reading on the staff was 0.930m. By similarly elevating the sight the bubble readings were -012.6, E5.7 and staff reading 1.025m



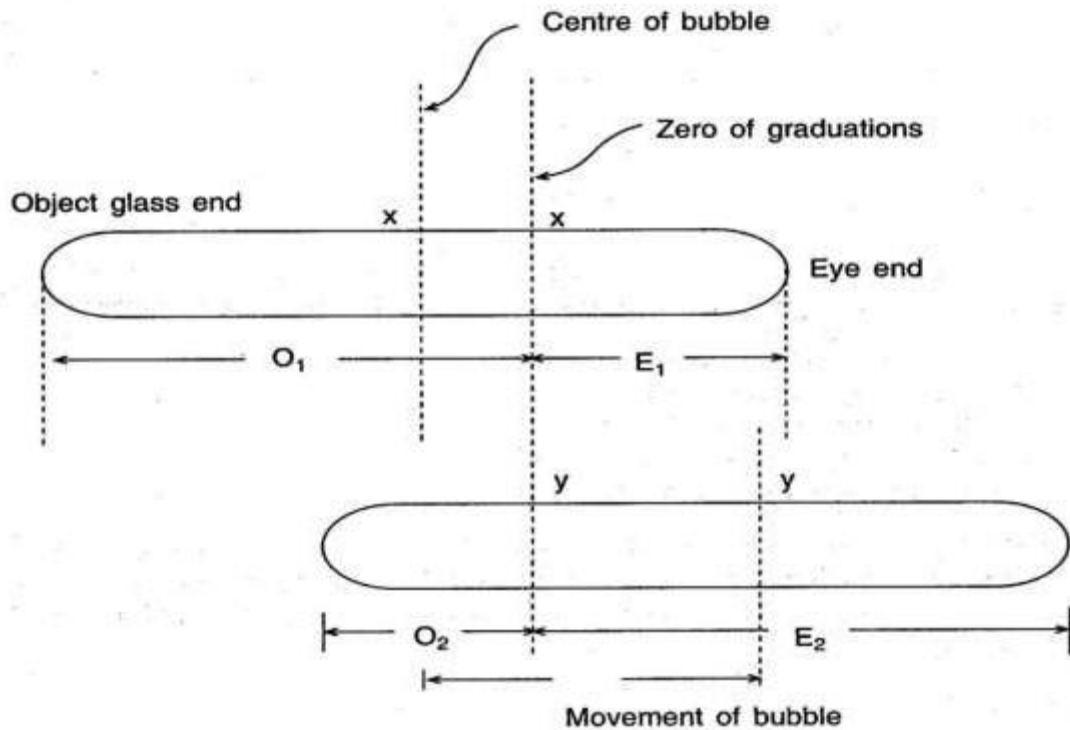

Fig.

Determine the sensitivity of the bubble and the radius of curvature of the bubble tube if the length of one division is 2.50 mm.

**Solution**

$$\begin{aligned}
 n &= \frac{O_1 - E_1}{2} + \frac{E_2 - O_2}{2} \\
 &= \frac{4.1 - 14.4}{2} + \frac{5.7 - 12.6}{2} \\
 &= -\frac{10.3 + 6.9}{2} = -\frac{17.2}{2} = -8.6 \text{ divisions}
 \end{aligned}$$

(Negative because the line of sight is depressed and the bubble moves to the eyepiece end initially.)

$$\begin{aligned}
 \text{Sensitivity of bubble } \theta_{\text{sec}} &= \frac{206265S}{nl} \\
 &= \frac{206265(1.025 - 0.930)}{8.6(100)} \\
 &= 22.78''
 \end{aligned}$$

### Permanent adjustment of different types of levels:

The establishment of desired relationship between fundamental lines of a levelling instrument is termed as permanent adjustment. So, permanent adjustment indicates the rectification of instrumental errors.

The fundamental lines are as follows:

1. The line of collimation, (2) The axis of the bubble tube, (3) The vertical axis, (4) The axis of telescope.

The relationships between the lines are as follows:-

1. The line of collimation should be parallel to the axis of bubble tube, (2) The line of collimation should coincide with the telescope, (3) The axis of the bubble should be perpendicular to the vertical axis. i.e., the bubble should remain in the central position for all directions of the telescope.

Principle of reversal: If there is any error in a certain part of the instrument, then it will be doubled by reversing, i.e., by revolving the telescope through  $180^\circ$ . Thus the apparent error becomes twice the actual error on reversal. In a right-angled triangle  $ABC$ , the angle  $ACB$  is not exactly  $90^\circ$  but less by  $8^\circ$ . If this triangle is reversed as  $A_1B_1C$ , then the angle between the faces  $BC$  and  $B_1C$  becomes  $2 \times 8^\circ$ . This is the principle of reversal. By this principle, the relationship between the fundamental lines can be determined and hence necessary correction can be applied.

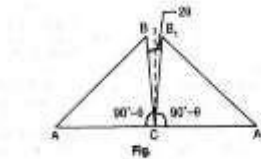

Fig:1.16

Permanent adjustment of dumpy level: (1) To make the axis of the bubble tube perpendicular to the vertical axis.

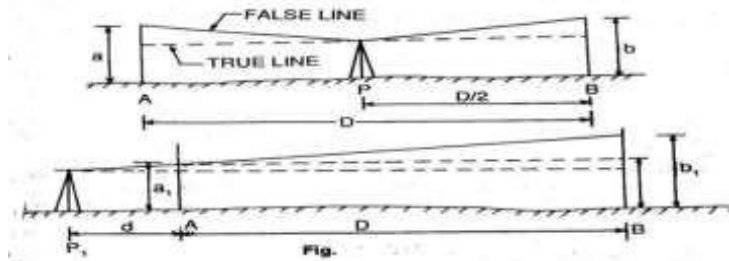

Fig:1.16

c) The level is set up on fairly level and firm ground, with its legs well apart. It is firmly fixed to the ground. (b) The telescope is placed parallel to any pair of foot screws and by turning the foot screws either both inward or both outward, the bubble is brought to the Centre. (c) The telescope is turned through  $90^\circ$ , so that it lies over the third foot screw. Then by turning the third foot screw the bubble is brought to the Centre. (d) The process is repeated several times until the bubble is in central position in both the directions. (e) Now the telescope is turned through  $180^\circ$  and the position of the bubble is noted. If the bubble still remains in the central position, the desired relationship is perfect. If not, the amount of deviation of the bubble is noted. (f) Suppose the deviation is  $2n$  divisions. Now by turning the capstan headed nut (which is at one end of the tube), the bubble is brought half-way back (i.e.  $n$  division). The remaining half division is adjusted by the foot screw or screw just below the telescope. (g) The procedure of adjustment is continued till the bubble remains central position of the telescope.

(2) Two peg method (1) Two pegs A and B are driven at a known distance apart (Say  $D$ ) on level and firm ground. The level is set up at  $P$ , just mid-way between A and B. After bringing the bubble to the Centre of its run (usual), the staff readings on A and B are taken. The staff readings are  $a$  and  $b$ . Now the difference of level between A and B is calculated, this difference is the true difference, as the level is set up just mid-way between BS and FS. Then the rise or fall is determined by comparing the staff readings. (b) The level is shifted and set up at  $P_1$  (very near to A), say at a distance  $d$  from A. Then after proper leveling (following usual method), staff readings at A and B are taken. Suppose the readings are  $a_1$  and  $b_1$ . Then the apparent difference of level is calculated. (c) If the true difference and apparent difference are equal, the line of collimation is in adjustment. If not, the line of collimation is inclined. (d) In the second set up, let  $e$  be the staff reading on B at the same level of the staff reading  $a_1$ . Then  $e = a_1 \pm \text{true difference}$  (use the positive sign in case of a fall and negative sign in case of Rise)

(e) If  $b_1$  is greater than  $e$ , the line of collimation is inclined upwards and if  $b_1$  is less than  $e$ , it is inclined downwards. Collimation error  $= b_1 - e$  (in a distance  $D$ ) (f) By applying the principle of similar triangles, Correction to far peg,  $C_2 = \frac{D+d}{D}(b_1 - e)$ , Correction to near peg,  $C_1 = \frac{d}{D}(b_1 - e)$

staff reading on A  $= a_1 \pm C_1$ , correct staff reading on B  $= b_1 \pm C_2$  (use the positive sign when the line of collimation is inclined downwards, and the negative sign when it is inclined upwards) (g) Then the cross hair is brought to the calculated correct reading by raising or lowering the diaphragm by means of the diaphragm screw.

Field procedures: (1) If the correct reading is seen below the collimation hair on looking through the telescope, the cross hair is to be lowered. This is done by loosening the upper screw and tightening the lower screw of the diaphragm. (2) If the correct reading is seen above the collimation hair, on looking through the telescope, the cross hair should be raised. This is done by loosening the lower screw and tightening the upper screw of the diaphragm.

## Setting grades and stakes:

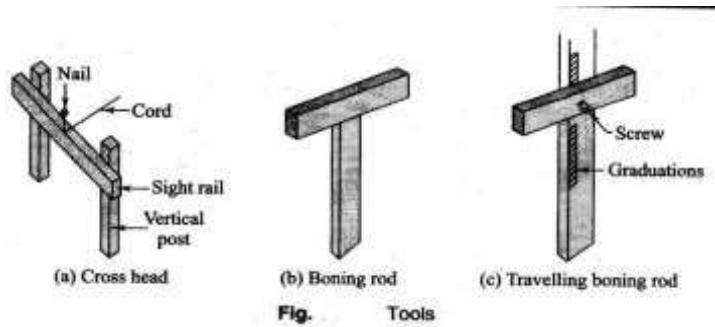

Fig:1.17

Setting out of sewer Lines: Underground pipelines and sewer pipes have to be laid to a particular gradient designed for the ease of flow of water or sewage. The inside bottom of the sewer pipe is known as invert. Some special tools are required to set the line gradient.

**Cross head:** It consists of two posts and horizontal bar. The posts are of suitable heavy cross section and the horizontal member, known as the sight rail, has an area of 50mmX150mm. cross heads are kept at the top and bottom of the gradient. The top of the sight rail is kept at a convenient height, 2-5m.

**Boning rod:** It resembles a cross. A vertical wooden piece measuring 100mm long, and is plotted at a convenient height depending upon the setting of the sight rail. The top of the boning rod is a reference for determining the depth of excavation in a section. One boning rod is required for a particular gradient. Different boning rods are required for different gradients.

**Travelling Rod:** It is an adjustable boning rod. The horizontal piece can be moved over the vertical piece thus varying the height of the rod.

## Setting out:

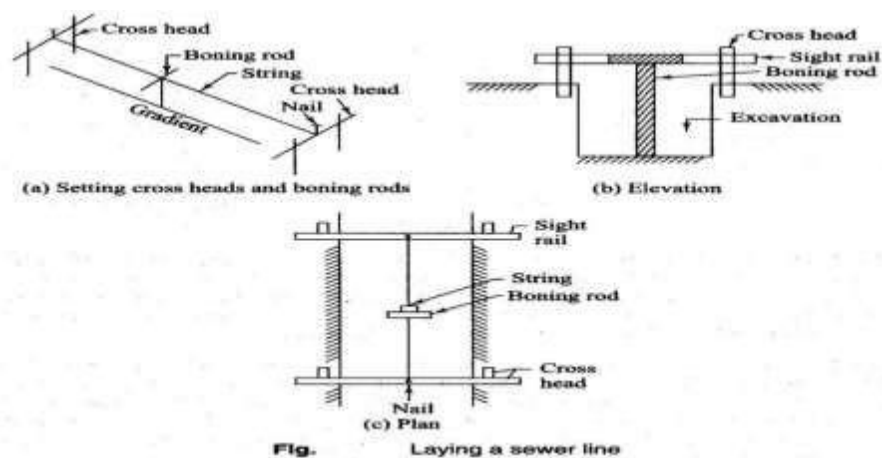

Fig. Laying a sewer line

Fig:1.17

To set out the sewer on the gradient, the following procedure is adopted.

- 1) Set the alignment of the line on the surface with reference to the control points brought near the site. Also establish the vertical control points for setting out the grade.
- 2) Lay a line parallel to the alignment for reference, as the first line will be lost once the excavation starts.
- 3) Start work from the lower point. Place the sight rails at the bottom and top of the gradient line. Drive nails at the Centre of the crop piece of the cross heads. Stretch a string between the nails to act as a reference for vertical distances.
- 4) Drive the cross heads in such a way that the top of the sight rail is 2-5m above the invert of the sewer. This may be done with a level and take the readings. The boning rod is used of same length as the setting of the sight rail in the gradient section.
- 5) The string stretched between the nails on the sight rails should have the same gradient as that of the sewer line.
- 6) Check the proper depth of the excavation at any intermediate point using the boning rod.

## CONTOURING:

2.1 Definitions of related terms, concepts of contours, characteristics of contours:

1) **Contourline:** The line of intersection of a level surface with the ground surface is known as the contour line or simply the contour. It can also be defined as a line passing through points of equal reduced levels.

**1) Contourline:** The line of intersection of a level surface with the ground surface is known as the contour line or simply the contour. It can also be defined as a line passing through points of equal reduced levels.

For example, a contour of 100 in indicates that all the points on this line have an RL of 100 m.

Similarly, in a contour of 99 m, all the points have an RL of 99 m, and so on (Fig.). A map showing only the contour lines of an area is called a contour map.

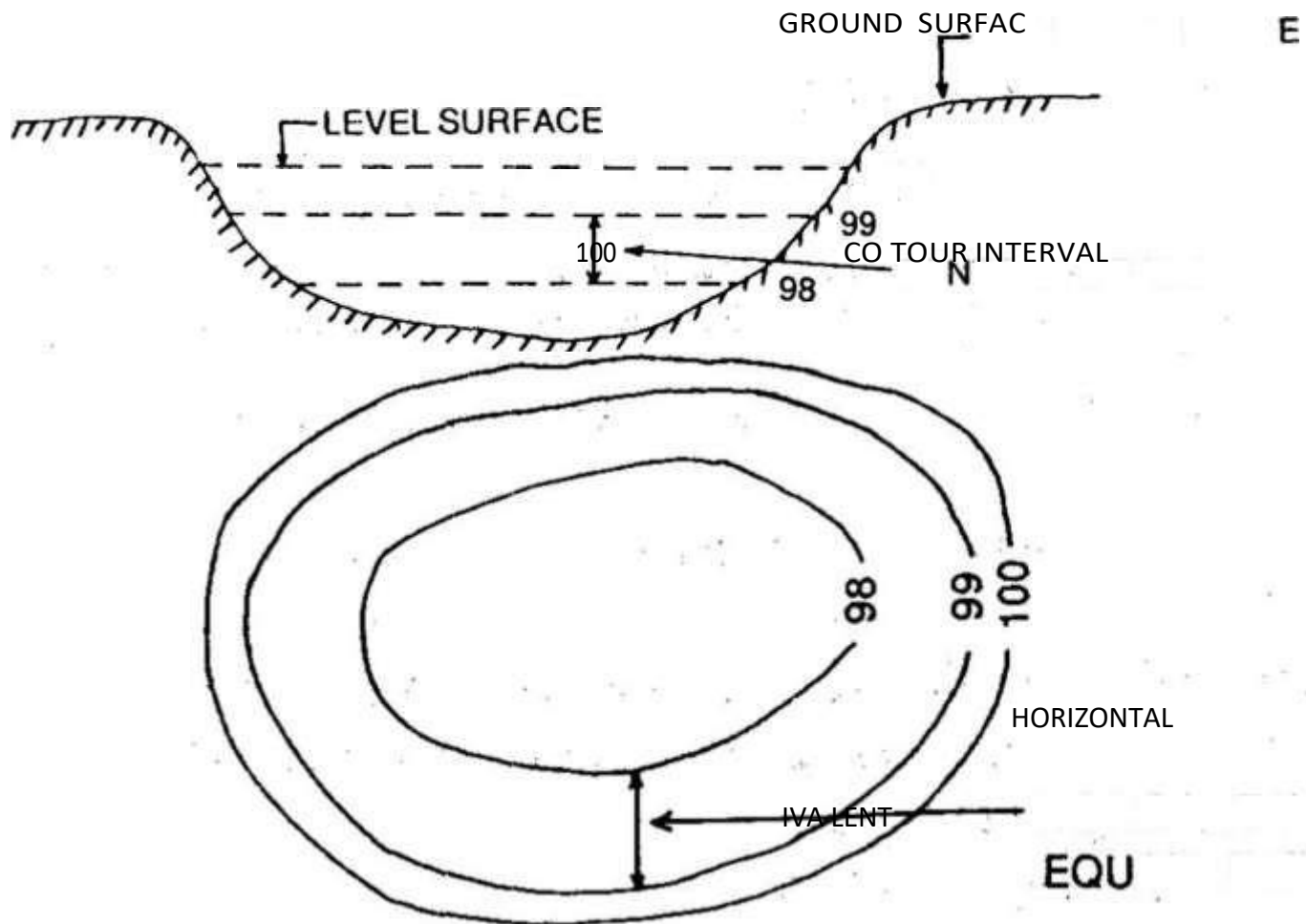

Fig.2.1

**2. Contour Interval:** The vertical distance between any two consecutive contours is known as a contour interval. Suppose a map includes contour lines of 100 in, 98 in, 96 in, and soon. The contour interval here is 2m. This interval depends upon: (i) the nature of the ground (i.e. whether flat or steep), (ii) the scale of the map, and (iii) the purpose of the survey.

Contour intervals for flat country are generally small, e.g. 0.25 in, 0.50 in, 0.75 in, etc. The contour interval for a steep slope in a hilly area is generally greater, e.g. 5 m, 10 m, 15 m, etc.

Again for a small-scale map, the interval may be of 1 in, 2 in, 3 in, etc. and for a large scale map it may be of 0.25m, 0.50m, 0.75m etc. It should be remembered that the contour interval for a particular map is constant. The horizontal distance between any two consecutive contours is known as horizontal equivalent. It is not constant. It varies according to the steepness of the ground. For steep slopes, the contour lines run close together, and for flatter slopes they are widely spread.

## 2.1: Methods of contouring, plotting contour maps

### OBJECT OF PREPARING CONTOUR MAP:

The general map of a country includes the locations of roads, railways, rivers, villages, towns, and soon. But the nature of the ground surface cannot be realized from such a map. However, for all engineering projects involving roads, railways, and so on, a knowledge of the nature of the ground surface is required for locating suitable alignments and estimating the volume of earth work. Therefore, the contour map is essential for all engineering project. This is why contour maps are prepared.

### USES OF CONTOUR MAP:

The following are the specific uses of the contour map:

The nature of the ground surface of a country can be understood by studying a contour map. Hence, the possible route of communication between different places can be demarcated.

A suitable site or an economical alignment can be selected for any engineering project. The capacity of a reservoir or the area of a catchment can be approximately computed.

The intervisibility or otherwise of different points can be established. A suitable route for a given gradient can be marked on the map.

A section of the ground surface can be drawn in any direction from the contour map. Quantities of earth work can be approximately computed.



**Characteristics of Contours: 1.** (Ref Fig.) the contour lines are closer near the top of a hill or high ground and wide apart near the foot. This indicates a very steep slope towards the peak and a flatter slope towards the foot.

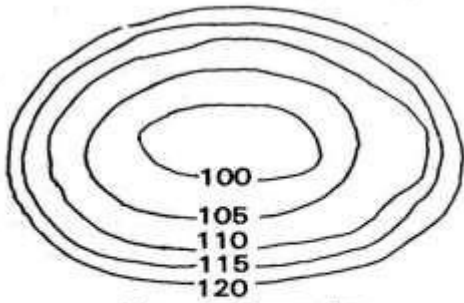

**Fig. Depression**

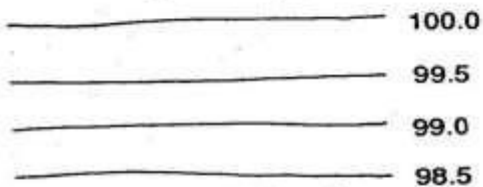

**Fig. Uniform Slope**

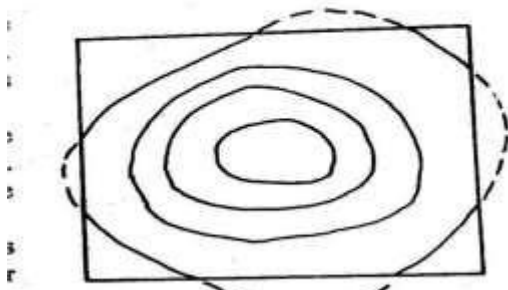

**Fig. Contour Closed within Map**

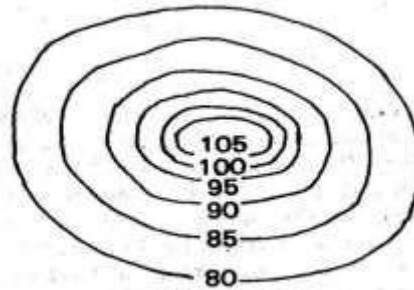

**Fig. Hill**

2. In Fig. the contour lines are closer near the bank of a pond or depression and wide apart towards the centre. This indicates a steep slope near the bank and a flatter slope at the centre.

3. Uniformly spaced, contour lines indicate a uniform slope (Fig. ' -').

4. Contour lines always form a closed circuit. But these lines may be within or outside the limits of the map (Fig.)

5. Contour lines cannot cross one another, except in the case of an overhanging cliff. But the over-lapping portion must be shown by a dotted line (Fig.).

6. When the higher values are inside the loop, it indicates a ridge line. Contour lines cross ridge lines at right angles (Fig. ' ').

7. When the lower values are inside the loop, it indicates a valley line. Contour lines cross the valley line at right angles (Fig.).

8. A series of closed contours always indicates a depression or summit. The lower values being inside the loop indicate a depression and the higher values being inside the loop indicate a summit. (Fig.).

9. Depressions between summits are called saddles (Fig.)

10. Contour lines meeting at a point indicate a vertical cliff.

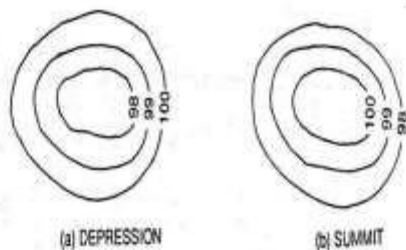
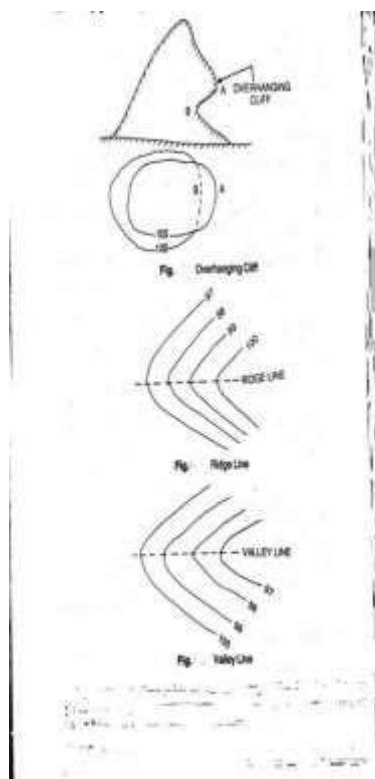

Fig.

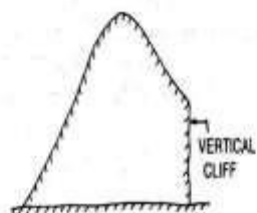

Fig. (a) Vertical Cliff

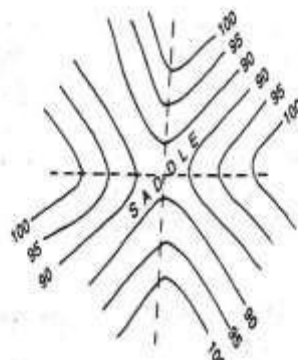

Fig. (b) Saddle

Fig:2.1

METHODS OF CONTOURING

There are two methods of contouring --- direct and indirect.

A) Direct Method:

There may be two cases, as outlined below.

**Case-I:** When the area is oblong and cannot be controlled from a single station: In this method, the various points on any contour are relocated on the ground by taking levels. Then these points are marked by pegs. After this, the points are plotted on the map to any suitable scale, by plane table. This method is very slow and tedious. But it gives accurate contour lines.

**Procedure:** 1) Suppose a contour map is to be prepared for an oblong area. A temporary Benchmark is set up near the site by taking fly level readings from a permanent benchmark. (2) The level is then set up at a suitable position L from where maximum area can be covered. (3) The Plane table is set up at a suitable station P from where the above area can be plotted. (4) A backsight reading is taken on the TBM. Suppose the RL of the TBM is 249.500 m and that the BS reading is 2.250 m. Then the RL of HI is 251.750 m. If a contour of 250.000 is required, the staff reading should be 1.750 m. If a contour of 249.000 is required, the staff reading should be 2.750 m, and so on. (5) The staff man holds the staff at different points of the area by moving up and down, or left and right, until the staff reading is exactly 1.750. Then, the points are marked by pegs. Suppose, these points are A, B, C, D, ....

6) A suitable point is selected on the sheet to represent the station P. With the alidade touching p, rays are drawn to A, B, C and D. The distances PA, PB, PC and PD are measured and plotted to a suitable scale. In this manner, the points a, b, c and d of the contour line of RL 250.000 m are obtained. These points are joined to obtain the contour of 250.000 m

7) Similarly, the points of the other contours are fixated. (8) When required, the levelling instrument and the plane table are shifted and set up in a new position in order to continue the operation along the oblong area.

**Case-II:** When the area is small and can be controlled from a single station: In this case, the method of radial lines is adopted to obtain contour map. This is also very slow and tedious, but gives the actual contour lines.

**Direct Method:**

- 1) The plane table is set up at a suitable station P from where the whole area can be commanded.
- 2) A point p is suitably selected on the sheet to represent the station P. Radial lines are then drawn in different directions.
- 3) A temporary bench-mark is established near the site. The level is set up at a suitable position L and a BS reading is taken on the TBM. Let the HI in this setting be 153.250 m. So, to find the contour of RL, 152.000 in a staff reading of 1.250 in is required at a particular point, so that the RL of contour of that point comes to 152.000 m.

$$\begin{aligned} \text{RL} &= \text{HI} - \text{Staff reading} \\ &= 153.250 - 1.250 = 152.000 \text{ in} \end{aligned}$$

4. The staff man holds the staff along the rays drawn from the plane table station in such a way that the staff reading on that point is exactly 1.25. In this manner, points A, B, C, D and E are located on the ground, where the staff readings are exactly 1.250. (5) The distances PA, PB, PC, PD and PE are measured and plotted to any suitable scale. Thus the points a, b, c, d and e are obtained which are joined in order to obtain a contour of 152.000. (6) The other contours may be located in similar fashion (Fig.).

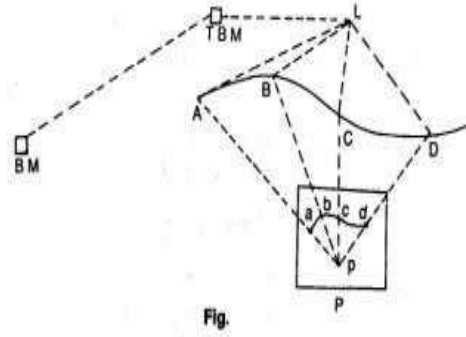
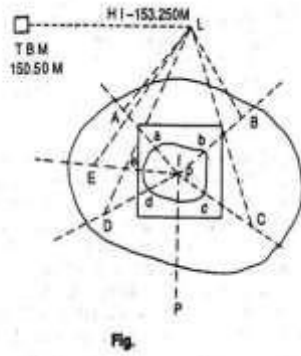

Fig:2.2

**Indirect Method:** In this method, the RLs of different points (spot levels) are taken at regular intervals along a series of lines set up on the ground. The positions of these points are plotted on a sheet to any suitable scale. The spot levels are noted at the respective points. Then the points of contour lines are found out by interpolation, after which they are joined together to give the required contour lines. Although very quick, this method gives only the approximate positions of the contour lines. This method can be adopted in two ways, (i) cross-sections, and (ii) squares.

**(a) Using Cross-sections:** In this method, a base line, centre line or profile line is considered. Cross-sections are taken perpendicular to this line at regular intervals (say 50 m, 100 m etc.). After this, points are marked along the cross-sections at regular intervals (say, 5 m, 10 m, etc.). A temporary bench mark is set up near the site. Staff readings are taken along the base line and the cross-sections. The readings are entered in the level book; the base line and the cross-sections should also be mentioned. The RL of each of the points is calculated. Then the base line and cross-sections are plotted to a suitable scale. Subsequently the RLs of the respective points are noted on the map, after which the required contour line is drawn by interpolation. This method is suitable for route survey, when the cross-sections are taken transversely to the longitudinal section.

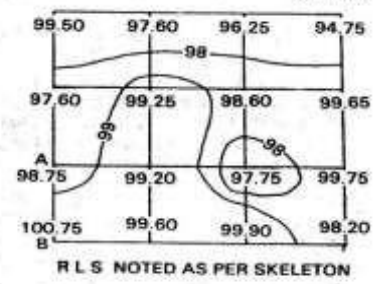
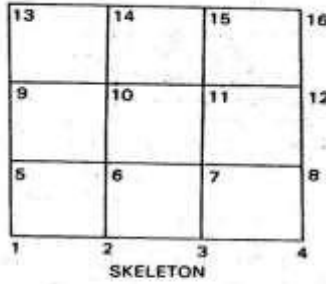
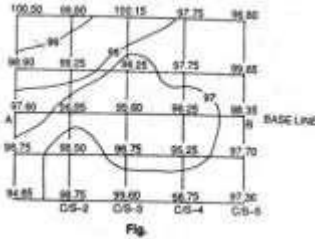

Fig:2.2

**(b) Using Squares:** In this method, the area is divided into a number of squares. The size of these squares depends upon the nature and extent of the ground. Generally they have sides varying from 5 to 20m. The corners of the squares are numbered serially, as 1,2,3,.....A temporary benchmark is set up near the site, and the level is set up at a suitable position. The staff readings on the corners of the squares are taken and noted in the level book maintaining the sequence of the serial numbers of the corners. The RLs of all the corners are recalculated. The skeletons of the squares are plotted to a suitable scale. The respective RLs on the corners, after which the contour lines are drawn by interpolation.

**Interpretation of contour maps, top sheets:**

**Method of Interpolation of Contours:** The process of locating the contours proportionately between the plotted points is termed interpolation. This can be done by:

(1) **Arithmetical Calculation:** Let A and B be two corners of the squares. The RL of A is 98.75m, and that of B 100.75m. The horizontal distance between A and B is 10m, Horizontal distance between A and B = 10m, Vertical distance between A and B = 100.75 - 98.75 = 2m, Let a contour of 99.00m be required. Then, difference of level between A and 99.00m contour = 99.00 - 98.75 = 0.25m, ∴ Distance

$$\frac{10}{2}$$

of 99.00m contour line from A =  $\frac{10}{2} \times 0.25 = 1.25$ m. This calculated distance is plotted to the same scale

in which the skeleton was plotted, to obtain a point of RL of 99.00m, Similarly the other points are located.

(2) **By graphical method:** On a sheet of tracing paper, a line AB is drawn and divided into equal parts. AB is bisected at C, and a perpendicular is drawn at this point. A point O is selected on this perpendicular. Then radial lines are drawn from O to the divisions on AB. These lines serve as guide



lines. The boundary line and every fifth line is marked with a thick or red line. Suppose we have to interpolate a 2m contour interval between two points a and b of RLs 92.5 and 100.75m. Let us consider the lowest radial line OB to represent an RL of 90.00. So every fifth line (which is bold or red) will represent 95.100, 105, etc. The tracing paper is moved over the plan until a lies at 92.5 and b at 100.25. Line ab should be parallel to AB. Now the points 94, 96, 98, 100 are picked through to obtain the positions of the required contour.

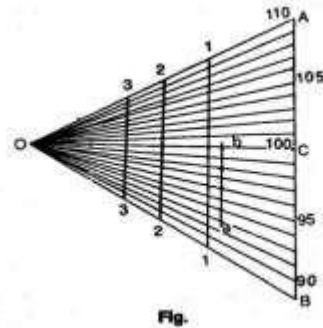

Fig:2.3

Use of contour maps on civil engineering projects-drawing cross-sections from contour maps, locating:

Since a contour map is a three dimensional representation of the earth's surface. it furnishes a lot of information. Some of the uses that a contour map can be put to are as follows.

**Determination of intervisibility:** Let it be required to ascertain the intervisibility of two stations A and B having elevations 62m and 90m, respectively, as shown in the contour map (Ref: fig.). Join A and B is 28m ( $90-62=28$ ). The line of sight will have an inclination of 28m in the distance ab. draw projections to mark points of elevation of 90, 85, ..., 62 on the line ab. Compare these points with the corresponding points in which the contours cut the line ab. At the point e, the ground has an elevation of 75 and 70m, whereas line of sight will have an elevation less than 75m (between 75 and 70m). It can be seen that there will be obstruction in the range CD. Similarly, checks can be made for the other points.

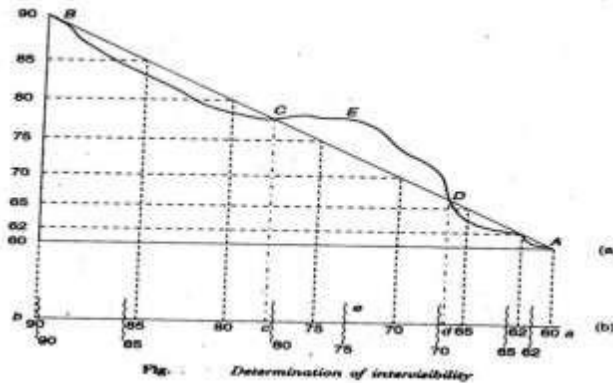

Fig:2.4

**Drainage area:** The extent of drainage area may be estimated on a contour map by locating the ridge line around the watershed. The ridge line should be located in such a position that the ground slopes are down on either side of it. The area is found out by Planimetric measurements.

**Capacity of reservoirs:** Reservoirs are made for water supply and for power or irrigation projects. A contour map is very useful to study the possible location of a dam and the volume of water to be confined. All the contours are closed lines within the reservoir area.

**Site of structures:** The most economical and suitable site for structures such as buildings, bridges, dams etc. can be found from large-scale contour maps.

**Earthquake estimates:** On the contour line of the original surface, the contours of the desired altered surface are drawn. By joining the intersections of the original contours and new ones of equal value, the line in which the new surface cuts the original is obtained. Excavation is required within this line, whereas the surrounding parts will be in the embankment. The volume of cut or a fill is found by multiplying the average by the contour interval.

**Route Location:** By inspecting a contour map the most suitable site for a road, railway, canal etc. can be selected. By following the contour lines, steep gradients, cutting and filling, etc. may be avoided.

## CHAPTER-8

### COMPUTATION OF AREA & VOLUME

#### Introduction:-

It is the space of a tract of land projected upon the horizontal plane and not to the actual area of the land surface.

It may be expressed in Square meters ( $m^2$ ), Hectares (1 hectare= 10000 $m^2$ ), Squarefeet, Acre.

#### Methods for computation of area:-

There are two methods of computation of the Area:-

*A. Graphical method*

*B. Instrumental method*

#### Calculation of area from Graphical method:-

The area may be calculated in two following ways:-

I. From field Notes

ii. From Plotted plan

#### Computation of the area from field notes

In this method the computation of the area is done in two steps:-

- a. In survey works the whole area is divided into number of some geometrical Fig. such as triangles, rectangles, square, trapeziums and then the area is calculated.
- b. Then the area of this geometrical fig. added up to get the required area.

#### Calculation of the area from Plotted plan:-

The area may be calculated in two following ways:-

I. Considering the entire area

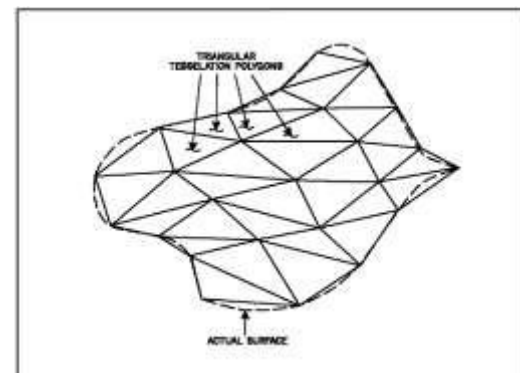

ii. Considering the Boundary area

**Considering the Entire area:-**The entire area is divided into regions of convenient shape and they are calculated by

a. **By dividing the area into triangles:-** The triangles are so drawn as to equalize the irregular boundary line. Then the bases and altitude of the triangles are determined according to the scale toto which plan is drawn. After this the areas of these triangles are calculated.(fig.1)

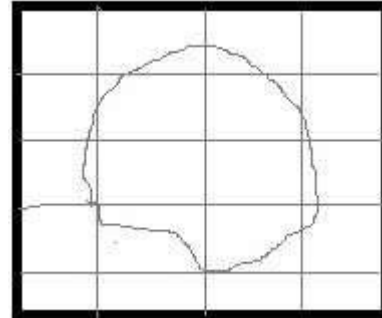

b. **By dividing the area into squares:-** In this method squares of equal size are ruled out on a piece of tracing paper. Each square represents a unit area which could be 1cm<sup>2</sup> or 1m<sup>2</sup>. The tracing paper is placed over the plan and the full squares are counted. The total area is then calculated by multiplying the number of squares by the unit area of each square

c. **By drawing parallel lines and converting them into rectangles:-** In this method, a series of equidistant parallel lines are drawn on a tracing paper. The constant distance represents a metre or cm. The tracing paper is placed over the plan in such a way the area is enclosed between parallel lines at the top and bottom. Thus the area is number of strips. The curved ends of the strips are replaced by perpendicular lines and no. of rectangles are formed. The sum of the lengths of the rectangles is then calculated.

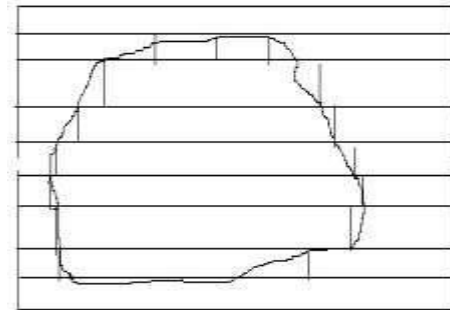

**Required Area=**  $\sum$  length of rectangle X constant distant

**Considering the Boundary area:-**In this method the large square or rectangle is formed with in the area in the plan. The ordinates are drawn at a regular interval from side of the square to the curved boundary. The middle area is calculated in the usual manner. The boundary area is calculated by

a. Mid Ordinate rule

b. Average ordinate rule

c. Trapezoidal rule

d. Simpson's rule

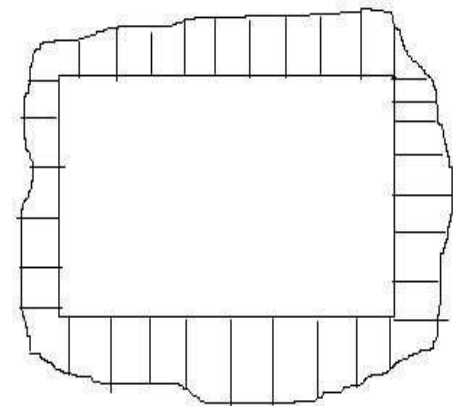

**Mid Ordinate rule:-**

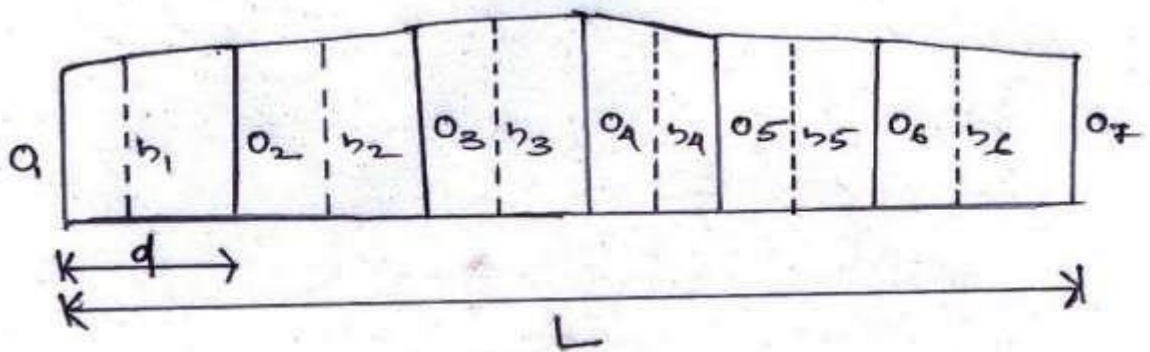

Let

$O_1, O_2, O_3, O_4, O_5, O_6, O_7, \dots, O_n$  = ordinates at equal intervals

$L$  = length of the base line

$d$  = Common distance between ordinates

$h_1, h_2, h_3, h_4, h_5, h_6, h_7, \dots, h_n$  = mid ordinates

Area of the plot =  $(h_1 \times d) + (h_2 \times d) + (h_3 \times d) + (h_4 \times d) + \dots + (h_n \times d)$

=  $d(h_1 + h_2 + h_3 + h_4 + h_5 + h_6 + h_7 + \dots + h_n)$

Where  $h_1 = (O_1 + O_2)/2$  and so on

Therefore the required area = common distance  $\times$  sum of the mid ordinates.

**Average ordinate rule:-**

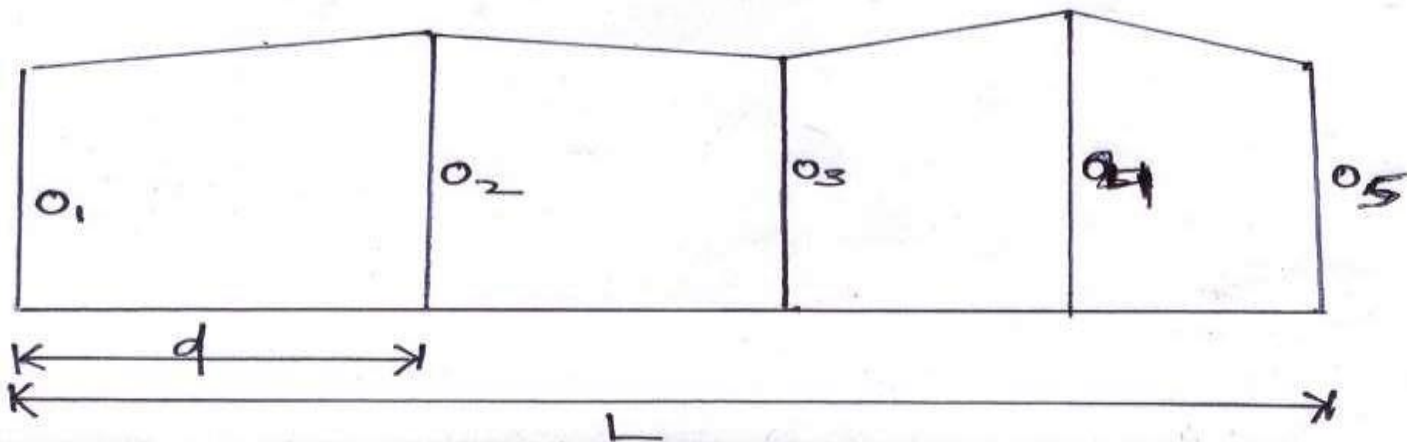

Let  $O_1, O_2, O_3, O_4, O_5, O_6, \dots, O_n$  = ordinates or offsets at regular intervals

$L$  = length of the base line

$n$  = no. of divisions

$n + 1$  = number of ordinates

$$\text{Area} = \frac{(O_1 + O_2 + O_3 + O_4 + O_5 + O_6 + \dots + O_n)}{n+1} \times L$$

**Trapezoidal rule:-**

While applying the trapezoidal rule boundaries between the ends of the ordinates are assumed to be straight. So, the area enclosed between the base line and the irregular boundary lines are to be considered as trapezoids.

Let,  $O_1, O_2, O_3, O_4, O_5, O_6, O_7, \dots, O_n$  = ordinates at equal intervals

$d$  = Common distance between ordinates

$L$  = length of the base line

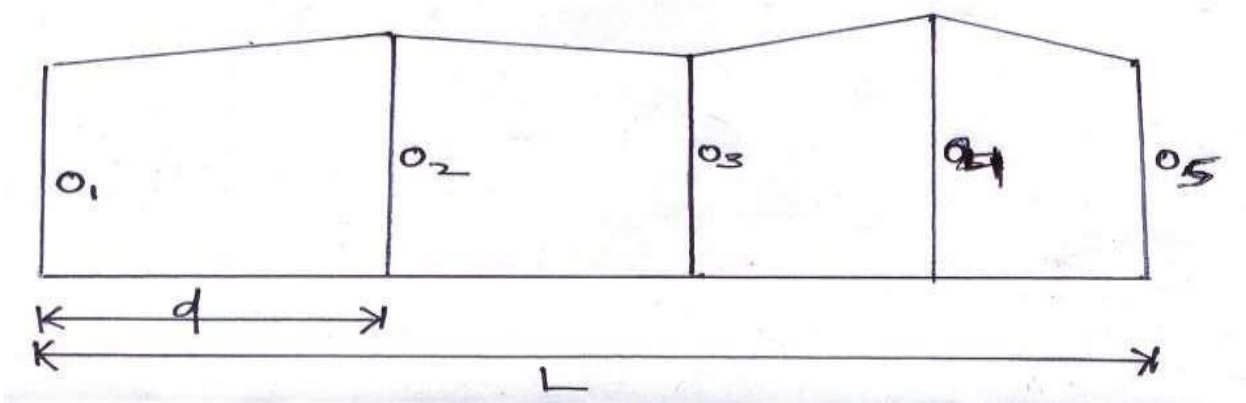

There fore,

$$1^{\text{st}} \text{ area} = \frac{O_1 + O_2}{2} \times d$$

$$2^{\text{nd}} \text{ area} = \frac{O_2 + O_3}{2} \times d$$

$$3^{\text{rd}} \text{ area} = \frac{O_3 + O_4}{2} \times d$$

$$4^{\text{th}} \text{ area} = \frac{O_4 + O_5}{2} \times d$$

..... and so on

$$\text{Last area} = \{ (O_{n-1} + O_n) \times d \} / 2$$

Therefore the required area = 1<sup>st</sup> area + 2<sup>nd</sup> area + 3<sup>rd</sup> area + 4<sup>th</sup> area + ..... + Last area

$$\begin{aligned}
 &= [ \{ (O_1 + O_2) \times d \} / 2 ] + [ \{ (O_2 + O_3) \times d \} / 2 ] + [ \{ (O_3 + O_4) \times d \} / 2 ] + [ \{ (O_4 + O_5) \times d \} / 2 ] + \dots + \{ (O_{n-1} + O_n) \times d \} / 2. \\
 &= d/2(O_1 + O_2 + O_2 + O_3 + O_3 + O_4 + O_4 + O_5 + O_5 + \dots + O_n) \\
 &= d/2(O_1 + 2O_2 + 2O_3 + 2O_4 + 2O_5 + \dots + O_n) \\
 &= \underline{\text{common distance}} \{ (1^{\text{st}} \text{ ordinate} + \text{last ordinate}) + 2(\text{sum of the other ordinates}) \}
 \end{aligned}$$

2

Therefore the **Trapezoidal rule** states that the sum of the first and last ordinate, twice the sum of the intermediate ordinates is added. This total sum is multiplied by the common distance. Half of this product is the required area.

**Limitation:-** There is no limitation. This rule can be applied for any number of ordinates

**Simpson's rule:-**

In this rule the boundaries between the ends of the ordinates are assumed to form an arc of parabola. Hence Simpson's rule is also known as parabolic rule. This rule is also known as Prismoidal rule.

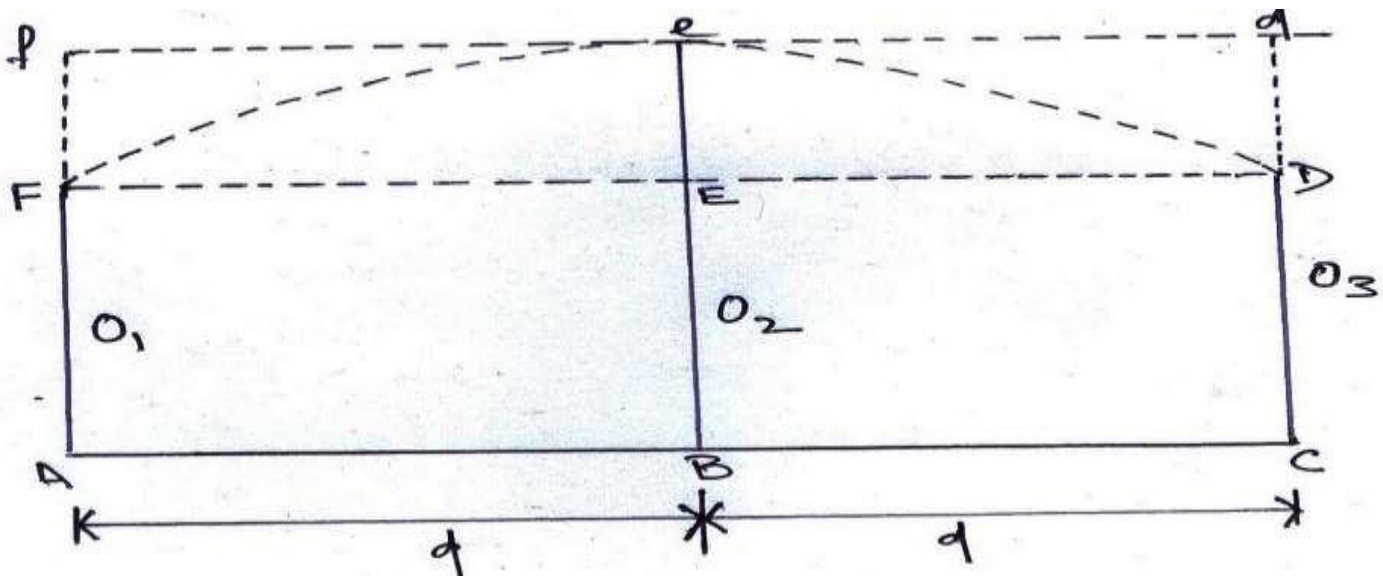

Let  $O_1, O_2, O_3 =$  three consecutive ordinates  
 $d =$  Common distance between ordinates

Therefore the required area  $A_{FeDC} =$  Area of the trapezium  $AFDC +$  Area of the segment  $FeDEF$

$$\text{Area of the trapezium } AFDC = \frac{O_1 + O_3}{2} \times 2d$$

$$\text{Area of the segment } FeDEF = \frac{2}{3} \times \text{area of the parallelogram}$$

$$\frac{2}{3}(Ee \times 2d) = \frac{2}{3} \times \left\{ O_2 - \frac{(O_1 + O_3)}{2} \right\} \times 2d$$

So, the area between the first two division is

$$A_1 = \left[ \frac{(O_1 + O_3)}{2} \times 2d \right] + \left[ \frac{2}{3} \times \left\{ O_2 - \frac{(O_1 + O_3)}{2} \right\} \times 2d \right]$$

$$= \frac{d}{3}(O_1 + 4O_2 + O_3)$$

Similarly, the area between two next division is calculated.....

$$A_2 = \frac{d}{3}(O_3 + 4O_4 + O_5)$$

$$A_3 = \frac{d}{3}(O_5 + 4O_6 + O_7) \text{ and so on}$$

$$\text{Required area} = A_1 + A_2 + A_3 \dots \dots \dots + A_n$$

$$= \left\{ \frac{d}{3}(O_1 + 4O_2 + O_3) \right\} + \left\{ \frac{d}{3}(O_3 + 4O_4 + O_5) \right\} + \left\{ \frac{d}{3}(O_5 + 4O_6 + O_7) \right\} + \dots \dots \dots$$

$$+ \left\{ \frac{d}{3}(O_{n-2} + 4O_{n-1} + O_n) \right\}$$

$$= \frac{d}{3} \left[ \{O_1 + O_n\} + 4(O_2 + O_4 + O_6 \dots \dots \dots + 4O_{n-1}) + 2(O_3 + O_5 + O_7 + \dots \dots \dots + O_{n-2}) \right]$$

$$= \frac{\text{common distance}}{3} \times \{ (1^{\text{st}} \text{ ordinate} + \text{last ordinate}) + 4 \times (\text{sum of the even ordinates}) + 2 \times (\text{sum of the odd ordinates}) \}$$

Therefore **Simpson's Rule** states that the sum of the first and last ordinate, four times the sum of the remaining even ordinates and twice the sum of the remaining odd ordinates are added. This total sum is multiplied by the common distance. One third of this product gives the required area.

**Limitation:-** This rule is only applicable when the number of divisions is even and ordinates are odd.



### **Difference between the Trapezoidal rule and Simpson's rule**

<b>Sl.no</b>	<b>Trapezoidal rule</b>	<b>Simpson's rule</b>
1.	The boundary between the ordinates is considered to be straight	The boundary between the ordinates is considered to be arc of a parabola
2.	There is no limitation. It can be applied for any number of ordinates	This rule is only applicable when the number of divisions is even and ordinates are odd.
3.	It gives an approximate result.	It gives an accurate result.